

EXPLODED VIEW & PARTS LISTING

Air Operated Double Diaphragm Pump

Model: NDP-25BV

Kynar Series

Rubber fitted w/metal center body

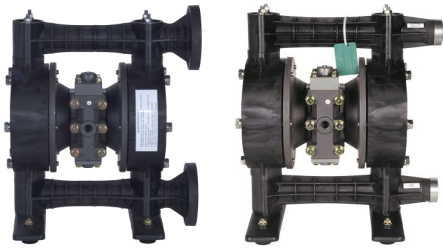

To Purchase:

☎ 800-990-7867

✉ sales@yamadapump.com

📍 Find My Rep

More Information:

▶ YouTube: @yamadapump

🌐 yamadapump.com

Data Sheets | CAD Drawings | Manuals Literature | BOM | Performance Curves

Trial Program

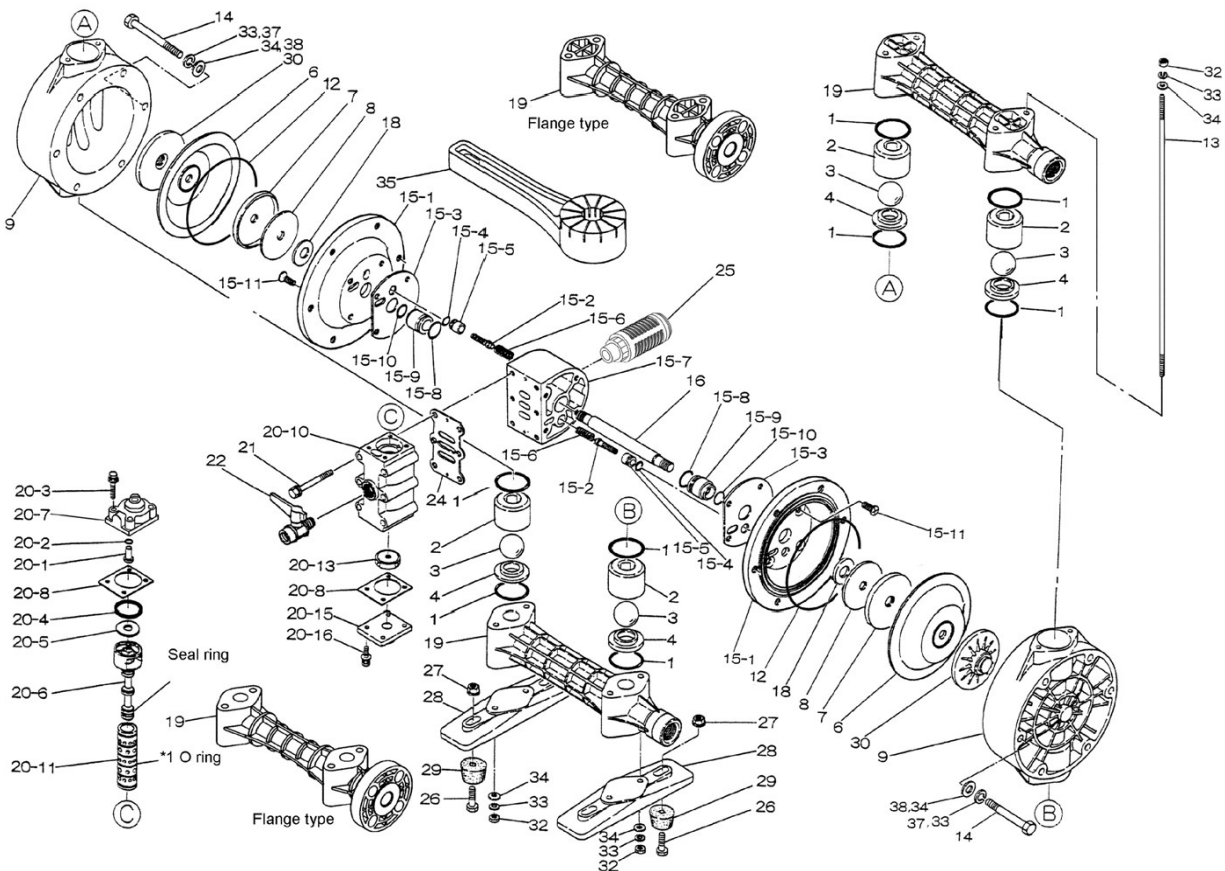

REF. NO.	PART NO.	PART NO.	PART NO.	PART NO.	DESCRIPTION	QTY.	REORDER
NPT	852811	852279	852773	852810	** NPT **		
FLANGE	853856	853859	853860	853857	** FLANGE **		
1	684119	643042	643042	642042	O-RING	4	
2	773419	773419	773419	773419	BALL GUIDE 25PVDF	4	
3	770590	773127	773171	770599	BALL	4	
4	780317	780317	780317	780317	VALVE SEAT 25VN	4	
5T	-	643041	643041	-	O-RING	4	
6	772963	771363	771974	772964	DIAPHRAGM	2	
7	716258	716258	716258	716258	CENTER DISK (INNER)	2	
8	716259	716259	716259	716259	WASHER (OUTER)	2	
9	780136	780136	780136	780136	OUT CHAMBER 25VN	2	
12	-	640154	640154	-	O-RING	2	
13	710207	710207	710207	710207	TIE ROD	4	
14	621189	621189	621189	621189	BOT	12	
15	804881	804881	804881	804881	BODY ASSY.	1	
15- 1	715940	715940	715940	715940	AIR CHAMBER	2	
15- 2	802360	802360	802360	802360	PILOT VALVE ASSY.	2	
15- 3	771057	771057	771057	771057	GASKET	2	
15- 4	640009	640009	640009	640009	O-RING	2	
15- 5	771945	771945	771945	771945	PILOT VALVE SEAT	2	
15- 6	708666	708666	708666	708666	SPRING	2	
15- 7	711503	711503	711503	711503	BODY	1	
15- 8	685276	685276	685276	685276	O-RING	2	
15- 9	772703	772703	772703	772703	THROAT BEARING	2	
15-10	685414	685414	685414	685414	V-PACKING	2	
15-11	682486	682486	682486	682486	BOLT FLAT HD W/ WASHE	8	
16	710271	710271	710271	710271	CENTER ROD	1	
18	771054	771054	771054	771054	CUSHION	2	
19	780314	780314	780314	780314	MANIFOLD 25VN - NPT	2	
19	780316	780316	780316	780316	MANIFOLD 25VN - FLANGE		
20	802809	802809	802809	802809	BODY VALVE ASSY.	1	
20- 1	709161	709161	709161	709161	RESET BUTTON	1	
20- 2	640005	640005	640005	640005	O-RING	1	
20- 3	682704	682704	682704	682704	BOLT M6 FT ZINC W/ WAS	4	
20- 4	771241	771241	771241	771241	PACKING	1	
20- 5	715961	715961	715961	715961	WASHER	1	
20- 6	802400	802400	802400	802400	C SPOOL ASSY	1	
20-6-seal	771053	771053	771053	771053	SEAL RING	5	
20- 7	711219	711219	711219	711219	CAP A 20/25PP	1	
20- 8	771240	771240	771240	771240	GASKET	2	
20-10	711640	711640	711640	711640	VALVE BODY	1	
20-11	803931	803931	803931	803931	SLEEVE ASSY	1	
20-11-*1	771080	771080	771080	771080	O-RING	6	
20-13	771914	771914	771914	771914	CUSHION	1	
20-15	711212	711212	711212	711212	CAP B 20/25PP	1	
20-16	682262	682262	682262	682262	BOLT M6 FT ZINC W/ WAS	4	
21	682265	682265	682265	682265	BOLT M8 PT ZINC W/ WAS	6	
22	684320	684320	684320	684320	BALL VALVE	1	
24	771056	771056	771056	771056	GASKET	1	
25	804697	804697	804697	804697	MUFFLER	1	
26	611153	611153	611153	611153	BOLT	4	
27	682276	682276	682276	682276	NUT W/FLANGE	1	
28	771749	771749	771749	771749	BASE 25V	2	
29	770551	770551	770551	770551	FOOT RUBBER	4	
30	780318	780318	780318	780318	CENTER DISK (OUTER)	2	
32	683635	683635	683635	683635	NUT	8	
33	681300	681300	681300	681300	SPRING WASHER	8	
34	631329	631329	631329	631329	FLAT WASHER	8	
35	771244	771244	771244	771244	TOOL	2	
37	680257	680257	680257	680257	SPRING WASHER	12	
38	631330	631330	631330	631330	FLAT WASHER	12	
KIT	K25-VE	K25-VH	K25-VS	K25-VV	LIQUID END KIT		
KIT		K225-AM			AIR MOTOR KIT		

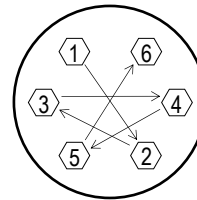

Tightening torque for center rod and out chambers.

Center Rod 29 ft-lbf {40 N-m}
 Out Chambers 8 ft-lbf {10 N-m}

Tightening torque for manifold retainer nuts.

BVE/H/S/V 10 ft-lbf {12 N-m}

General Tools:

- Socket wrenches - 10mm, 12mm, 13mm, 17mm, 22mm
- Hexagonal box wrench - 5mm
- Open-end wrench - 13mm

Special Tools:

- Accessory tool (771244) to remove the center disk (included).
- Sleeve remover (713148) (sold separately).

Miscellaneous:

- Assembly Oil - turbine oil none additional class 1 (equivalent to ISO VG32 grade)
- Nuts - M14 x 1.5
- Urea grease grade (NLGI) No. 2
- Lubricants - equivalent to Loctite anti-seize 767

Customer Notes

Model #: _____

Description: _____

Serial #: _____

Date Installed: _____

Department Location: _____

Tag/Project: _____