

SPECIFICATIONS:

MODEL NUMBER: 8005-911-288

PUMP DESIGN: Positive Displacement 3 Chamber Diaphragm Pump

CHECK VALVE: (1-Way Operation) Prevents Reverse Flow

CAM: 2.0 Degree

MOTOR: Permanent Magnet, P/N 11-150-10, Thermally Protected

VOLTAGE: 115 VAC Nominal

PRESSURE SWITCH: Adjustable Shut-Off (Range 85-100 PSI)

Factory Set @100 PSI, Turn On 85 PSI ± 5 PSI

LIQUID TEMPERATURE: 180 Degrees Fahrenheit (82 Degrees Centigrade) Max.

PRIME: Self-Priming Up To 6.5 Ft. Vertical,

Max. Inlet Pressure 30 PSI (2.1 Bar)

PORTS: 3/8"-18 NPT, Female

MATERIAL OF CONSTRUCTION:

PLASTICS- Nylon

VALVES- EPDM

DIAPHRAGM- Santoprene

FASTENERS- Zinc Plated Steel

NET WEIGHT: 4.9 Lbs (2.2 Kg)

DUTY CYCLE: Intermittent (See Temperature Rise Chart)

APPROVALS: NSF Listed, UL/CSA Recognized

TYPICAL APPLICATIONS: In-Line Carbonator

BYPASS: 80 PSI

DIMENSIONS:

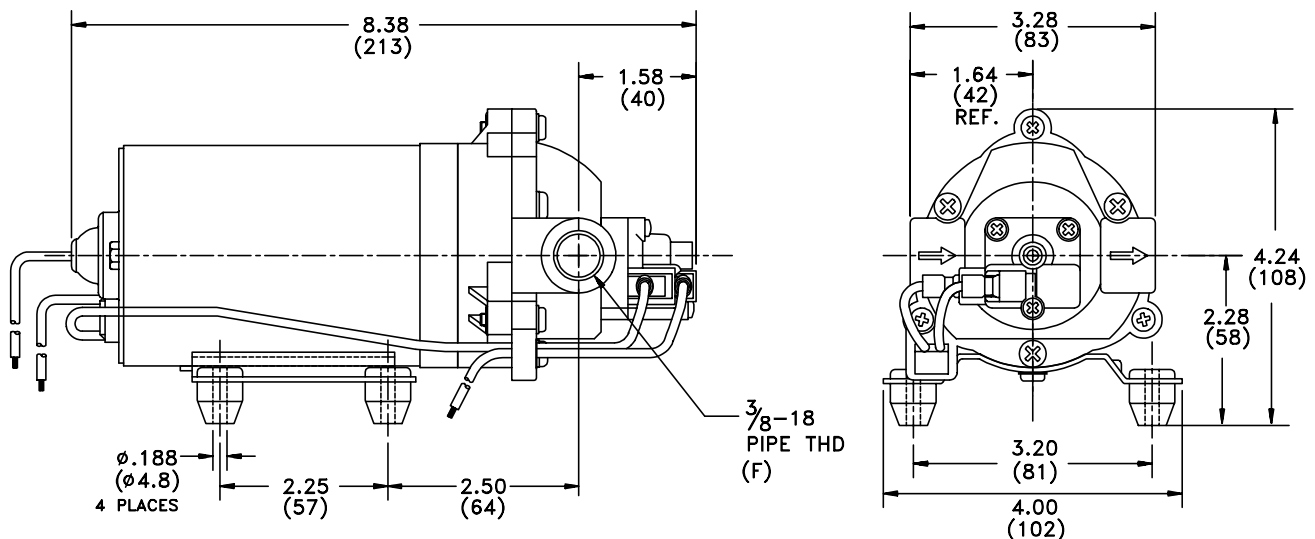

TEMPERATURE RISE

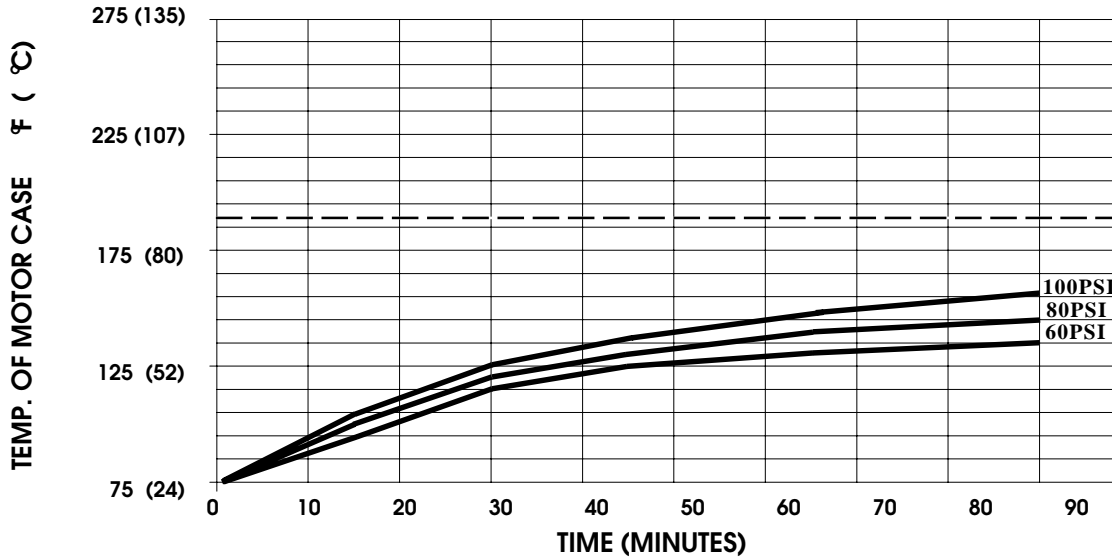

THIS GRAPH IS FOR USE AS A DESIGN GUIDE. IT IS BASED ON RUNNING CONTINUOUSLY WITH AN AMBIENT TEMPERATURE OF 70°F IN STILL AIR. THE THERMAL BREAKER WILL OPEN WHEN THE CASE TEMPERATURE REACHES 190° F.

[- - - - - TRIP POINT OF THERMAL PROTECTOR]

TYPICAL PERFORMANCE

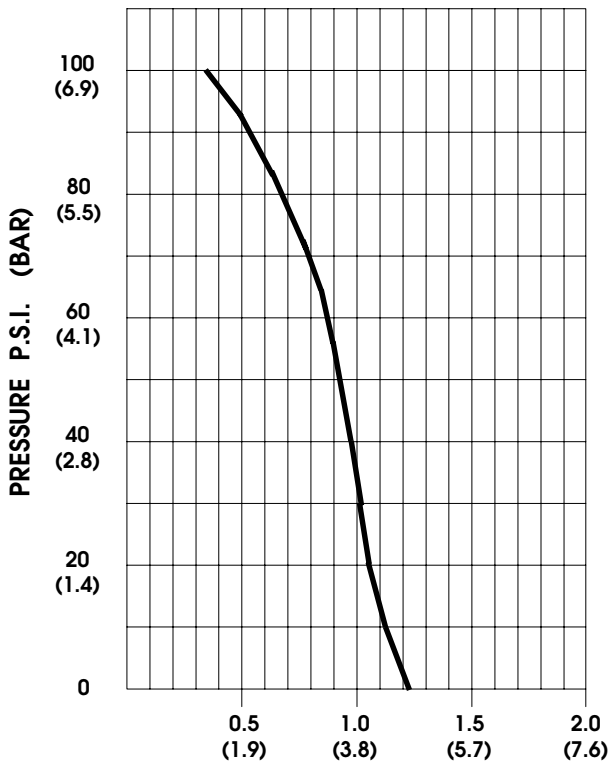

PRESSURE (PSI)	FLOW (GPM/LIT)	RPM MIN/MAX	CURRENT (AMPS)	VOLTAGE (VOLTS)
OPEN	1.23/4.6	2230/2300	0.33	115 VAC
10	1.13/4.3	2180/2265	0.38	"
20	1.04/3.9	2125/2200	0.43	"
30	1.00/3.8	2075/2140	0.48	"
40	0.95/3.6	2020/2090	0.53	"
50	0.92/3.5	1965/2030	0.58	"
60	0.88/3.3	1915/1980	0.63	"
70	0.83/3.1	1855/1940	0.67	"
80	0.75/2.8	1800/1890	0.72	"
90	0.60/2.3	1760/1845	0.77	"
100	0.35/1.3	1710/1800	0.82	"

-SPECIFICATIONS SUBJECT TO CHANGE WITHOUT NOTICE.

-ALL DATA BASED ON TESTING WITH WATER AT AMBIENT TEMPERATURE.