

**SPECIFICATIONS:**

- MODEL NUMBER:** 8005-243-256
- PUMP DESIGN:** Positive Displacement 3 Chamber Diaphragm Pump
- CHECK VALVE:** (1-Way Operation) Prevents Reverse Flow
- CAM:** 3.0 Degree
- MOTOR:** Permanent Magnet, P/N 11-148-04, Thermally Protected
- VOLTAGE:** 12 VDC Nominal
- PRESSURE SWITCH:** Adjustable Shur-Off (Range 40-60 PSI)  
 Factory Set @ 60 PSI, Turn on 45 PSI  $\pm$  5 PSI
- LIQUID TEMPERATURE:** 170 Degrees Fahrenheit (77 Degrees Centigrade) Max.
- PRIME:** Self-Priming Up To 10 Ft. Vertical,  
 Max. Inlet Pressure 30 PSI (2.1 Bar)
- PORTS:** 3/8"-18 NPT Female
- MATERIAL OF CONSTRUCTION:**
  - PLASTICS-** Polypropylene
  - VALVES-** EPDM
  - DIAPHRAGM-** Santoprene
  - FASTENERS-** Zinc Plated Steel
- NET WEIGHT:** 3.8 Lbs (1.72 Kg)
- DUTY CYCLE:** Intermittent (See Temperature Rise Chart)
- APPROVALS:** NSF Listed
- TYPICAL APPLICATIONS:** Water Delivery
- BYPASS:** 45 PSI

**DIMENSIONS:**

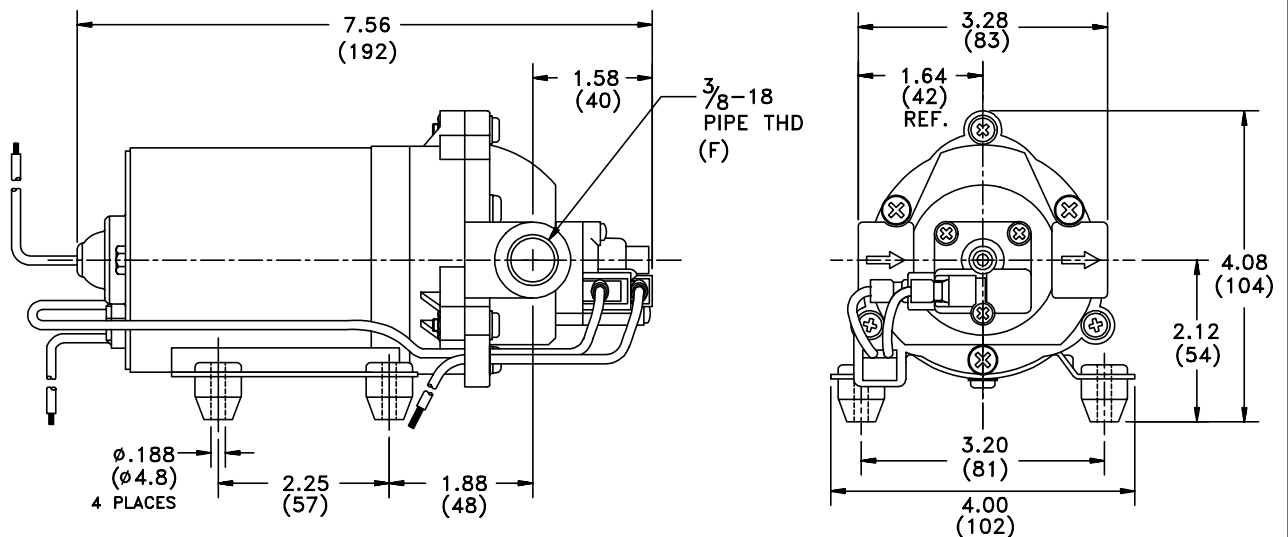

**TEMPERATURE RISE**

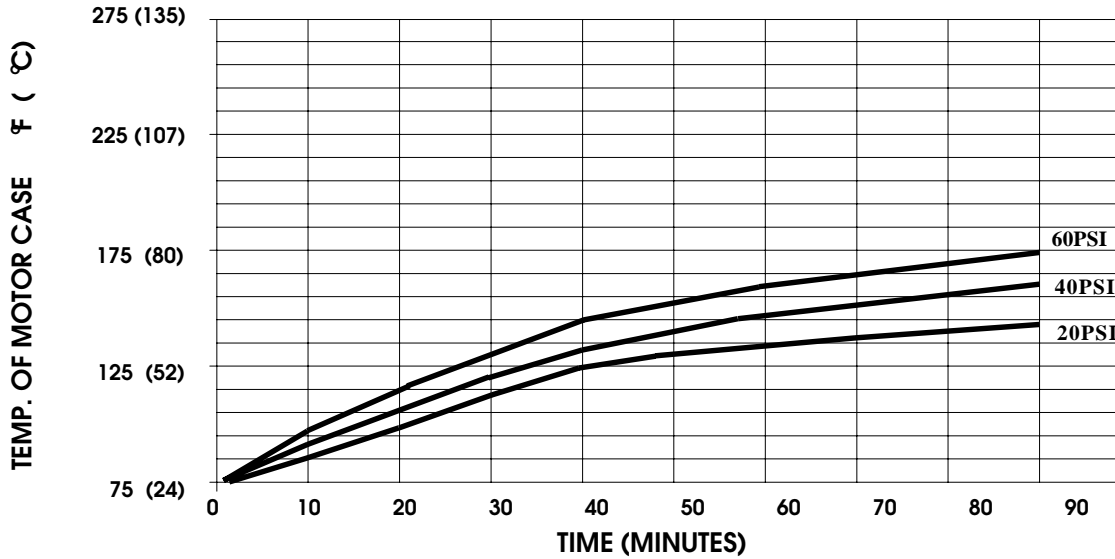

THIS GRAPH IS FOR USE AS A DESIGN GUIDE. IT IS BASED ON RUNNING CONTINUOUSLY WITH AN AMBIENT TEMPERATURE OF 70°F IN STILL AIR. THE THERMAL BREAKER WILL OPEN WHEN THE CASE TEMPERATURE REACHES 250° F.

[----- TRIP POINT OF THERMAL PROTECTOR]

**TYPICAL PERFORMANCE**

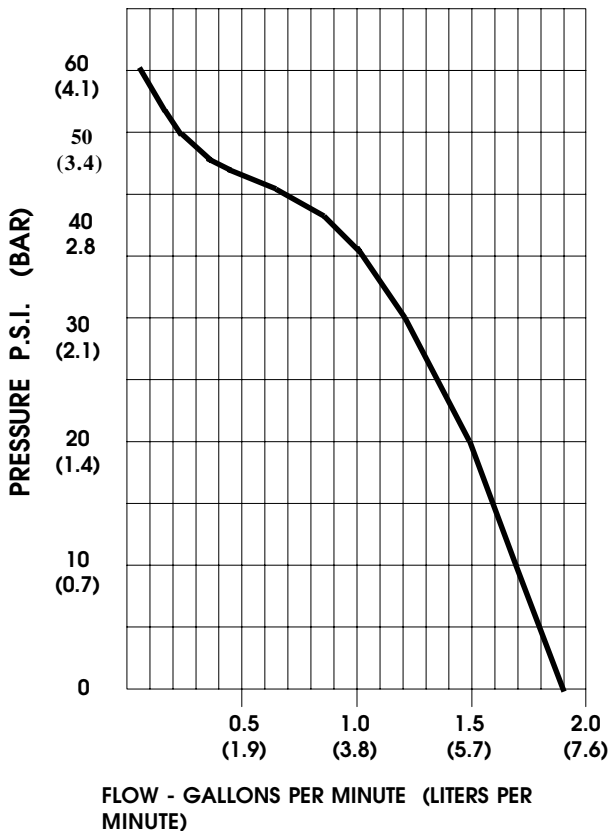

PRESSURE (PSI)	FLOW (GPM/LIT)	RPM MIN/MAX	CURRENT (AMPS)	VOLTAGE (VOLTS)
OPEN	1.36/5.1	1890/1950	2.1	12 VAC
10	1.25/4.7	1845/1900	2.6	"
20	1.13/4.3	1750/1810	3.2	"
30	0.95/3.6	1695/1735	3.7	"
40	0.66/2.5	1650/1665	4.2	"
50	0.17/0.6	1590/1610	4.5	"
60	0.01/.03	1565/1585	4.7	"

-SPECIFICATIONS SUBJECT TO CHANGE WITHOUT NOTICE.

-ALL DATA BASED ON TESTING WITH WATER AT AMBIENT TEMPERATURE.