



# MARINE PRODUCT DATA SHEET

**OEM: 357-111-00 (700 GPH)**  
**AFTERMARKET: 357-111-10 (700 GPH)**

Everything you are looking for in a bilge pump. Our tough, high density nylon housing and heavy duty water cooled motor gives the SHURflo Bilge Pump unparalleled reliability. Installations are a snap with our unique swivel baseplate and extended 6' tinned wire and assembly. Easy installation and removable cartridge for easy cleaning.

### TYPICAL APPLICATIONS

12V Marine Bilge Water Evacuation. For other applications, Contact SHURflo.

### PUMP

Type: Centrifugal Pump  
Port: 3/4" Barb  
Liquid: 130 °F [54 °C] Max  
Prime: Flooded Inlet  
Run Dry: No

### ELECTRICAL

Motor: 12VDC Permanent Magnet, Continuous Duty  
Protection: External Fuse  
Leads: 6 ft (1.8M) Tinned, 16 AWG  
Fuse: 5 Amp Recommended  
Control: No Control

### MATERIALS

Housing: High Strength Nylon  
Impeller: High Strength Nylon  
Hardware: Stainless Steel

### APPROVALS

Ignition Protected, CE, ISO 8846

### WARRANTY

3 Year Limited Warranty  
See SB-1050 For Full Warranty Details

### SHIPPING

Net Weight (Boxed): 1.25 Lb (0.56 Kg) each  
Carton Weight: 30 Lb [13.6 Kg]  
Pumps in Carton: 24  
Carton Size: 24"L x 18"W x 11" H [61 cm x 46 cm x 28 cm]

### RELATED DOCUMENTS

Catalog: MS-030-140  
Installation Manual: 911-593-00  
Maintenance: 911-593-00  
Applications Spec Guide: MS-020-005  
Warranty: SB-1050

### Replacement Kits

94-006-00



94-007-00



**PERFORMANCE @ 13.6V DC**

PRESSURE		FLOW		CURRENT
METERS	FT OF HEAD	GPH	LPH	AMPS
0.0	0	726	2747	3.90
1.20	4	631	2388	3.86
2.40	8	458	1733	3.70

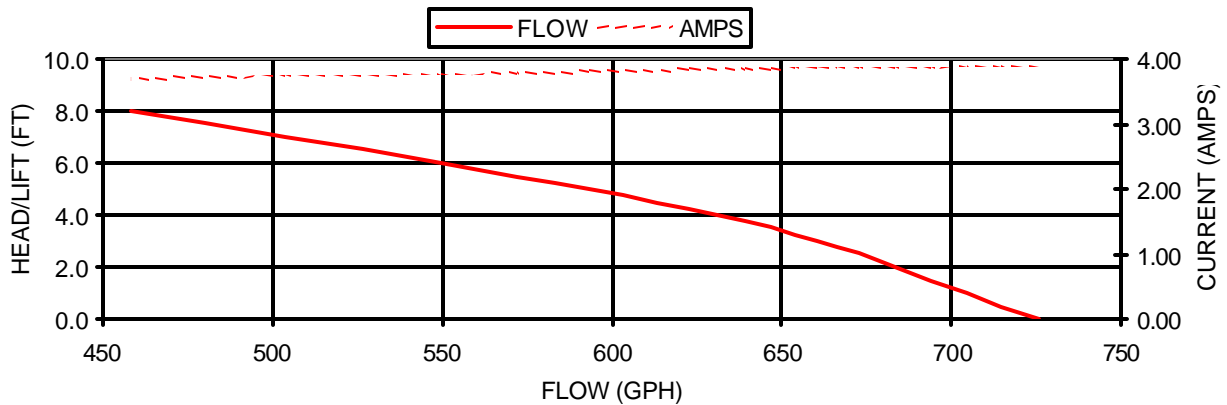

**DIMENSIONS [mm]**

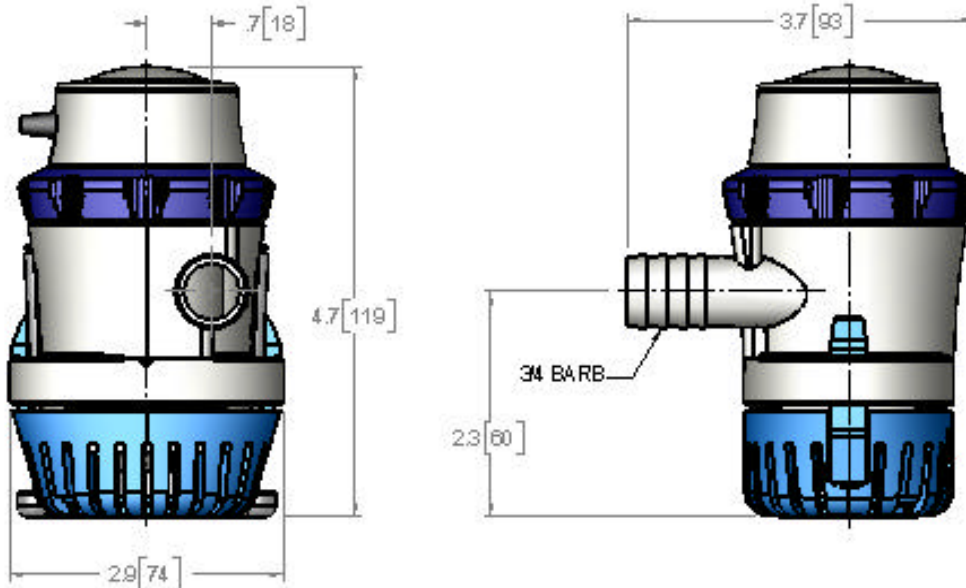

\*ISO Registered Facility

*SHURflo reserves the right to update specifications, prices, or make substitutions.*



SHURflo \*  
 5900A Katella Ave.  
 Cypress, Ca. 90630  
 (800) 854-3218 (562) 795-5200  
 FAX (562) 795-7554  
 Shipping/UPS: 5900C Katella Ave.  
 Cypress, Ca. 90630

SHURflo East  
 52748 Park Six Court  
 Elkhart, IN 46514-5427  
 (800) 762-809 (574) 262-0478  
 FAX (574) 264-2169  
 Http://www.shurflo.com  
 ©2001

SHURflo Ltd. \*  
 Unit 5 Sterling Park  
 Gatwick Road, Crawley  
 West Sussex, RH10 2QT  
 United Kingdom  
 +44 1293 424000  
 FAX +44 1293 421880