

**SPECIFICATIONS:**

**MODEL NUMBER:** 2088-483-124

**PUMP DESIGN:** Positive Displacement 3 Chamber Diaphragm Pump

**CHECK VALVE:** (1-Way Operation) Prevents Reverse Flow

**CAM:** 3.0 Degree

**MOTOR:** Permanent Magnet, P/N 11-179-00

**VOLTAGE:** 36 VDC Nominal

**PRESSURE SWITCH:** Factory Set @ 45 PSI Shut-Off, Turn On  $25 \pm 5$  PSI  
Adjustable From 30 to 50 PSI

**LIQUID TEMPERATURE:** 130 Degrees Fahrenheit (54 Degrees Centigrade) Max.

**PRIME:** Self-Priming Up To 9 Ft. Vertical,  
Max. Inlet Pressure 30 PSI (2.1 Bar)

**PORTS:** 1/2" - 14 Male Parallel Thread

**MATERIAL OF CONSTRUCTION:**

**PLASTICS-** Polypropylene

**VALVES-** Santoprene

**DIAPHRAGM-** Santoprene

**FASTENERS-** Zinc Plated Steel

**NET WEIGHT:** 4.8 Lbs (2.18 Kg)

**DUTY CYCLE:** Continuous

**TYPICAL APPLICATIONS:** Carpet Cleaning

**DIMENSIONS:**

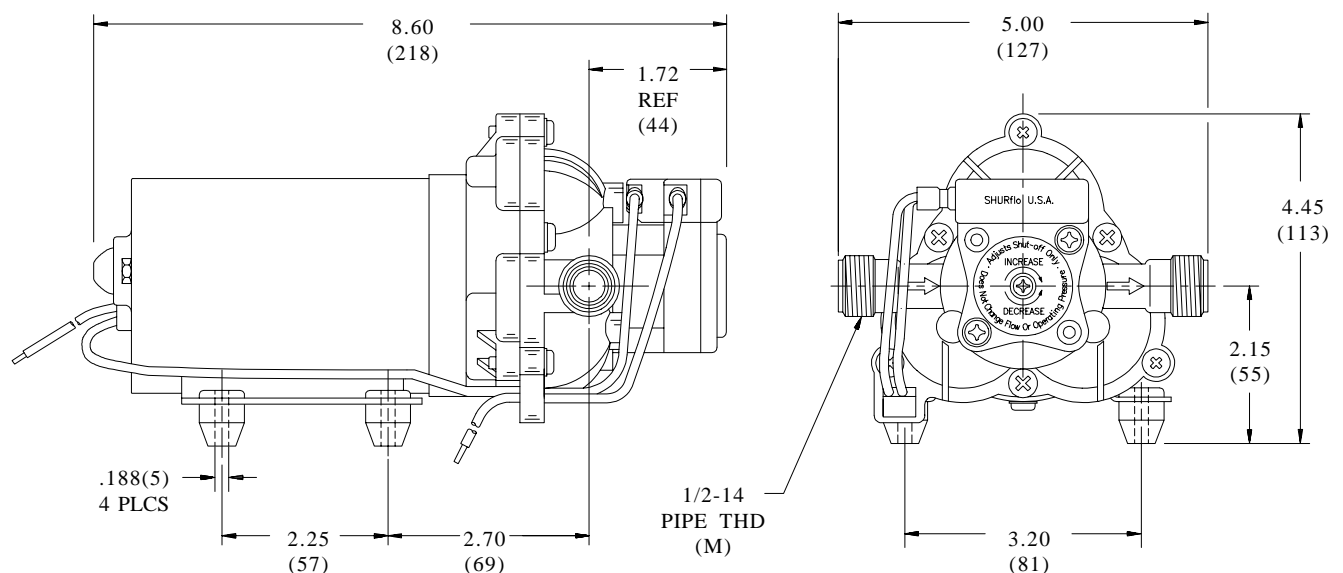

**TEMPERATURE RISE**

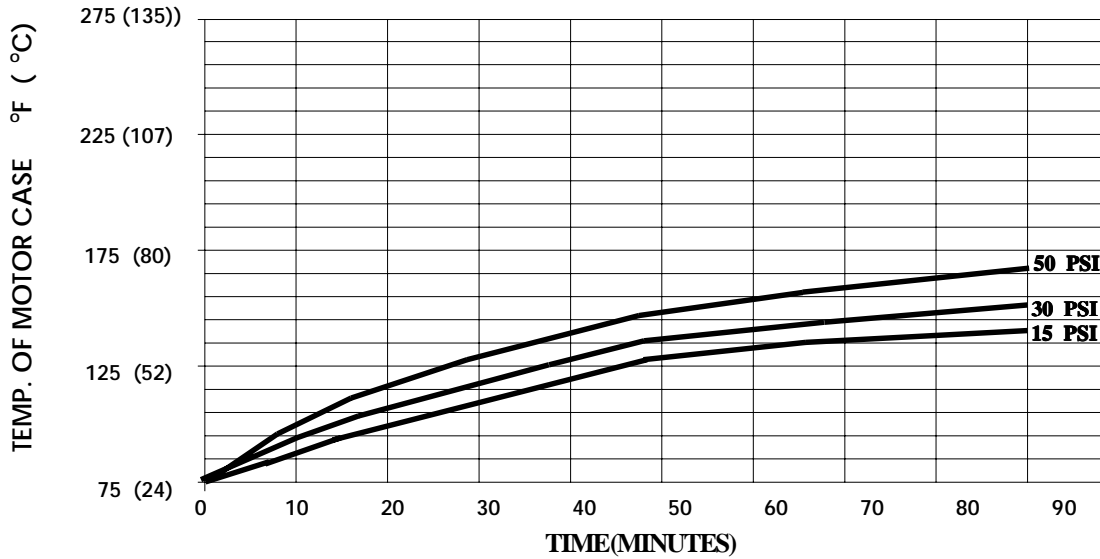

THIS GRAPH IS FOR USE AS A DESIGN GUIDE. IT IS BASED ON RUNNING CONTINUOUSLY WITH AN AMBIENT TEMPERATURE OF 75° F IN STILL AIR.

**TYPICAL PERFORMANCE**

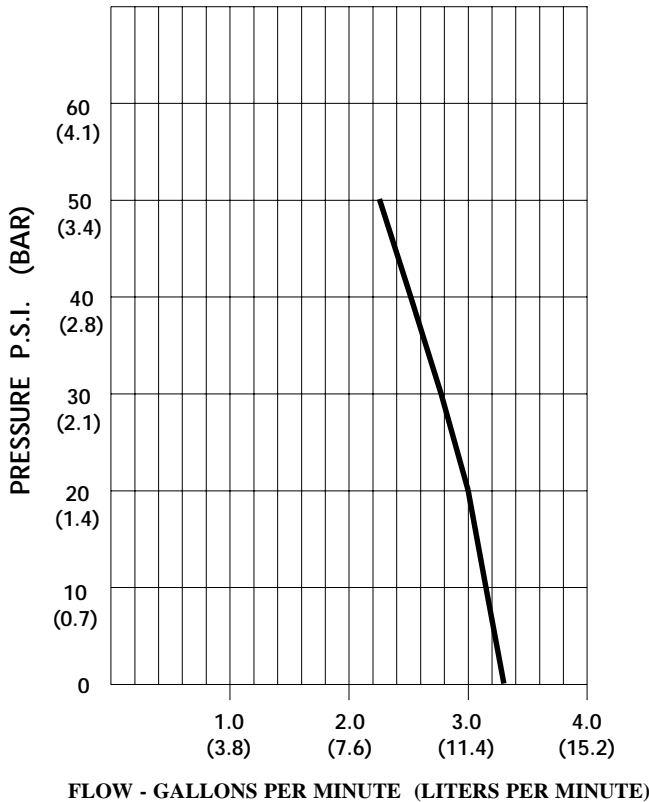

PRESSURE (PSI)	FLOW (GPM/LIT)	RPM MIN/MAX	CURRENT (AMPS)	VOLTAGE (VOLTS)
OPEN	<b>3.30/12.4</b>	<b>2460/2430</b>	<b>2.0</b>	<b>36 VDC</b>
10	<b>3.16/12.0</b>	<b>2440/2400</b>	<b>2.1</b>	"
20	<b>3.00/11.3</b>	<b>2400/2360</b>	<b>2.5</b>	"
30	<b>2.76/10.4</b>	<b>2370/2310</b>	<b>2.9</b>	"
40	<b>2.52/9.5</b>	<b>2350/2275</b>	<b>3.2</b>	"
50	<b>2.26/8.5</b>	<b>2345/2265</b>	<b>3.5</b>	"

*-SPECIFICATIONS SUBJECT TO CHANGE WITHOUT NOTICE.  
-ALL DATA BASED ON TESTING WITH WATER.*