

Established 1958



Marine Products for Power & Sail

Lectra/san®

LST/MC™



Smallest, most popular U.S. Coast Guard certified Type I Marine Sanitation Device for environmentally friendly treatment of waste and legal overboard discharge on inspected and uninspected vessels up to 65 feet.

Benefits

- Microprocessor control (MC) monitors conditions inside the treatment unit and automatically informs users of changes in water conditions
- One-step activation with toilet switch or LST/MC™ touch pad automatically activates toilet and treatment system
- Light sequence on the Control Indicator Panel indicates system functions and changes in salt and voltage conditions
- Generates its own natural disinfectant from salt water
- Coated electrodes use salt water to kill bacteria and viruses without adding harmful chemicals to the sea
- Discharges with treatment levels that are safe for environmentally sensitive areas
- Eliminates the need for bulky holding tanks in areas that have not been declared No Discharge Zones by the U.S. EPA
- Treats each flush as waste is generated
- Can be used with two marine toilets
- Easy to install
- Can be used with both manual and electric toilets
- Each unit is assembled by hand, individually tested and backed by Raritan's one-year Limited Warranty and legendary technical support team

Options

- Available for 12, 24 and 32V DC
- Optional toilet sensor starts treatment unit when manual toilet is flushed
- Optional control available for use with two toilets
- Optional salt feed systems available when using fresh or brackish water

Raritan manufactures equipment for pleasure boats throughout the world. Products include marine toilets, waste treatment systems, icemakers and water heaters.

Committed to the environment and preserving sea life, Raritan designs products to help maintain an environmental balance and ensure the quality of marine waters. In addition, the company has achieved ISO 9001:2000 certification for quality.

Innovation Through Experience

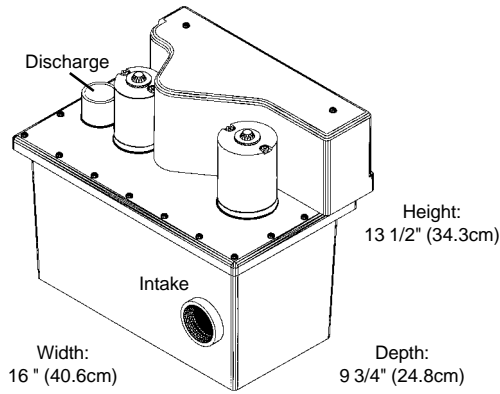

Approximate Shipping Weight: 20 lbs (9 kg)

The LST/MC utilizes improved electrodes which temporarily convert salt water into a powerful bactericide. The treated waste water then safely and conveniently reverts back to its original state of salt and water. No unnatural or harmful chemicals enter our environment.

The design of the treatment tank optimizes the thoroughness of treatment by forcing the bactericide and bacteria into direct contact, effectively killing viruses and bacteria.

The Lectra/San can be installed with one or two marine toilets to form a complete sanitation system. Pressing the "PUSH TO FLUSH" touch pad activates the treatment cycle. The toilet(s) can be interfaced with the LST/MC to provide one touch toilet flushing and treatment activation. The Control Indicator Panel provides visual monitoring of a variety of diagnostics.

Operation

The flushing action of the toilet discharges waste into the first chamber of the Treatment Tank. Here the waste is macerated and receives its first treatment. Specially coated electrode plates create an electrical field and convert salt water into hypochlorous acid, a powerful bactericide. Once the treatment solution reacts with bacteria and waste, it reverts back to salt and water.

The next time the toilet is flushed and new untreated discharge water enters the first chamber, some of the treated discharge enters the second chamber. While the new waste is being treated in the first chamber, the contents of the second chamber are stirred and treated again. Each successive flush moves the previous toilet discharge through the Lectra/San and eventually overboard or into a holding tank. When the discharge enters the marine environment, virtually all bacteria and viruses have been eliminated.

USCG TYPE I MSD CERTIFICATION

#159.015/107/1

Sample Installation

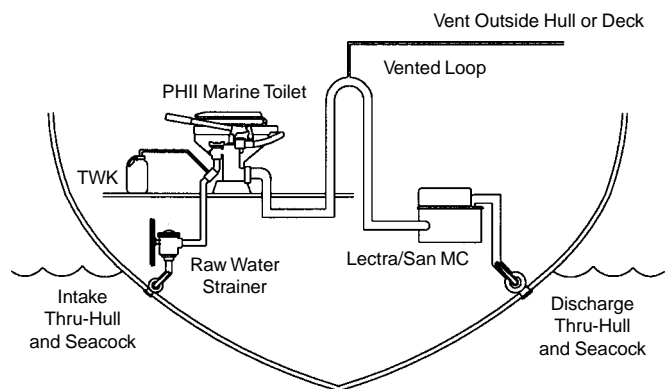

Lectra/San MC with Vented Loop (Above Waterline)

For more information contact:

Raritan Engineering Company Inc.
530 Orange Street, PO Box 1157
Millville, NJ 08332, USA
Telephone: 856-825-4900
FAX: 856-825-4409
e-mail: info@raritaneng.com
www.raritaneng.com

Southern Plant and Office
3101 SW 2nd Avenue
Ft. Lauderdale, FL 33315 USA
Telephone: 954-525-0378
FAX: 954-764-4370



L1039 0203kgs

Innovation Through Experience