

ATLANTES FREEDOM

Household Style Marine Toilet

Model A7, A8 and A9 Manufactured after July 2005)

THE FOLLOWING ARE CAUTIONARY STATEMENTS THAT MUST BE READ AND FOLLOWED DURING BOTH INSTALLATION AND OPERATION

WARNING: *Raritan Engineering Company, Inc. recommends that a qualified person or electrician install this product. Equipment damage, injury to personnel or death could result from improper installation. Raritan Engineering Company, Inc. accepts no responsibility or liability for damage to equipment, or injury or death to personnel that may result from improper installation or operation of this product.*



WARNING: HAZARD OF FLOODING - Always shut off seacocks before leaving the boat unattended. Double clamp all below waterline hose fittings and check frequently for integrity.



HAZARD OF SHOCK OR FIRE - Always use recommended fuse, circuit breaker and wire size.

**A7 and A8 Models
with Flush Lever**



**A9 Model with Wall Switch
Flush Control Panel**

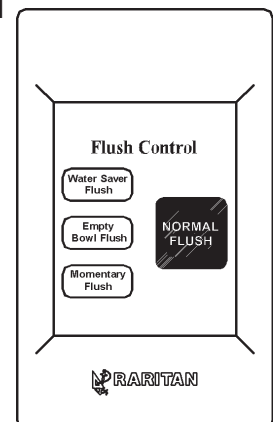
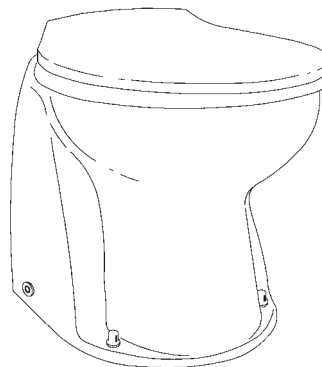

INTRODUCTION

The Atlantes is Raritan's best electric macerating toilet. All working parts fit inside the one-piece porcelain bowl on Integral Intake Pump models. The powerful centrifugal macerating pump thoroughly breaks down waste in preparation for treatment or holding. Three systems are available:

- **Integral Intake Pump** - for above waterline installations only.
- **Remote Intake Pump** - for above and below waterline installations.
- **Freshwater Solenoid Valve** - for flushing with pressurized fresh water.



1-800-352-5630
www.raritaneng.com

Flush Lever

The A7 model

The A7 model is designed to work as a momentary unit using only microswitches to activate the motors. It is also a “fail safe” mode for the toilet control in the A8 model.

The A8 model

The A8 model contains an electronic toilet control which provides timed operation while still having momentary functionality if toilet control is removed.

Operation:

pull handle forward:

Model A8 - starts a timed flush, intake pump starts followed by discharge pump.

Model A7 - Hold until waste is cleared from bowl.

push handle backward:

In both models runs just the discharge pump for a “dry bowl” flush.

Note: To terminate a cycle in case of emergency push handle all the way back and hold till both motors stop.

The A9 model

The A9 model contains an electronic box and functions with wall mounted flush control.

Wall mounted Flush Control

NORMAL FLUSH

Press “Normal Flush” - starts a timed flush, intake pump starts followed by discharge pump.

WATER SAVER FLUSH

Press “Water Saver Flush” starts a timed flush using half the water of a normal flush

EMPTY BOWL FLUSH

Press and hold “Empty Bowl Flush” touch pad until all water is removed from bowl.

MOMENTARY FLUSH

Press and hold “Momentary Flush” touch pad to flush bowl momentarily.

NOTE: To discontinue a “timed flush” press and release any button.

FLUSH LEVER POSITIONS

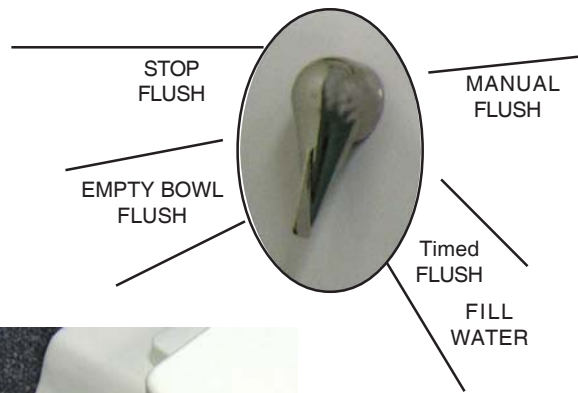

Pull Handle



Push Handle

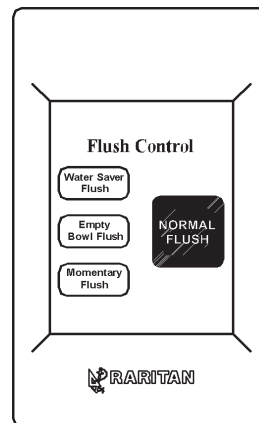

Wall Mounted Flush Control

Cleaning Instructions

IMPORTANT: Do not use cleaners that contain ammonia, ethyl acetate, phosphoric acid or concentrated chlorine bleach. These may cause damage to the toilet.

We recommend using Raritan C.P. (#1PCP22), a bio-enzymatic toilet bowl cleaner.

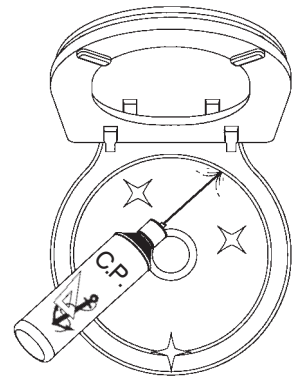

Cleaning In-Line Strainer

(Sea Water Models only)

1. Shut off intake seacock.
2. Unscrew bowl.
3. Remove filter.
4. Clean bowl and filter, wipe with a clean dry cloth.
5. Clean gasket and gasket contact surfaces thoroughly.
6. Replace gasket, filter and bowl.
7. Open seacock.
8. Check for leaks.

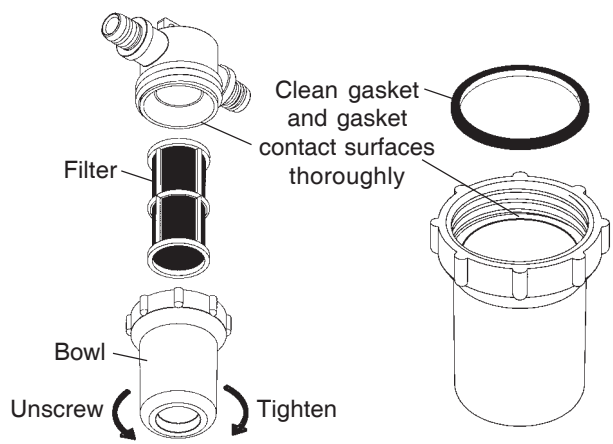

Refilling

Optional Atlantes Deodorant System (ADS)

Intake pump models only

Using Raritan Concentrate (#CON22) helps keep the bowl clean and lubricates internal parts.

Pour 8 oz. (237ml) of concentrate into tank and fill with water.

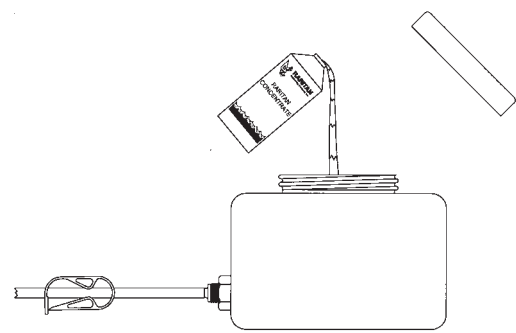

IMPORTANT

- **Improper winter lay up is a major cause of marine toilet failure.**
- **Use only nontoxic antifreeze.**
- **Flush toilet several times to clear waste from system.**
- **Dispose of all antifreeze in accordance with local and federal regulations.**
- **Winterize holding tanks, plumbing, treatment systems (MSD's), etc. independently following manufacturer's instructions.**

Pressurized Freshwater Models

Parts Required

- 1 1/2" (38mm) I.D. piece of discharge hose, approximately 3 feet (1m) long
- Two buckets
- Nontoxic antifreeze approximately 1 quart (1 liter).

Steps

1. Close discharge seacock.
2. Shut off intake water at source.
3. Turn off power to unit.
4. Disconnect and drain discharge hose.
5. Disconnect intake hose from intake water source and drain.
6. Connect hose to toilet's discharge and place in other bucket.
7. Pour antifreeze in toilet bowl.
8. Turn on power to unit and flush until antifreeze is removed from bowl and water is drained from solenoid valve and hose.
9. Disconnect power to toilet.

Integral and Remote Intake Pump Models

Parts Required

- 3/4" (19mm) I.D. piece of intake hose approximately 3 feet (1m) long.
- 1 1/2" (38mm) I.D. piece of discharge hose approximately 3 feet (1m) long.
- Two buckets
- Nontoxic antifreeze approximately 1 quart (1 liter).

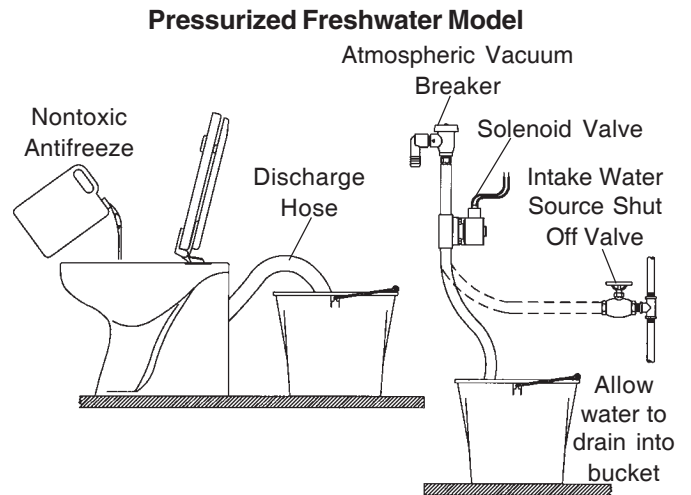

Sea Water Model (Integral Pump)

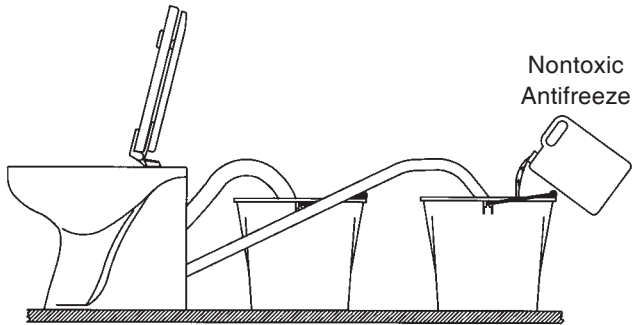

Sea Water Model (Remote Pump)

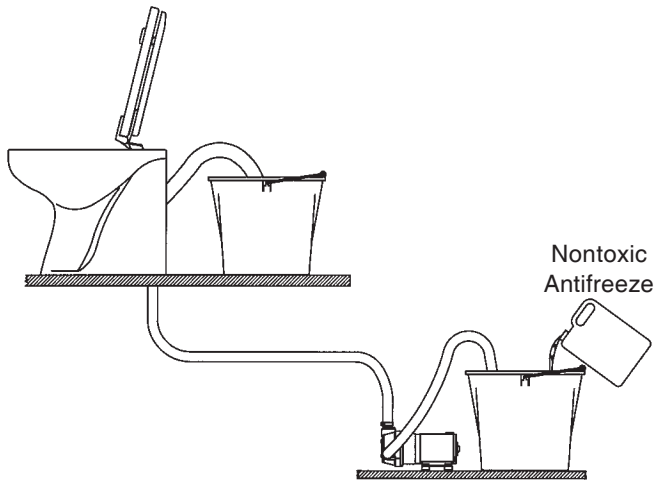

Steps

1. Close intake and discharge seacocks.
2. Turn off power to unit.
3. Disconnect and drain intake hose, discharge hose and In-Line Strainer.
4. Connect short hoses to toilet's intake and discharge.
5. Place one bucket under hose connected to toilet's discharge.
6. Pour nontoxic antifreeze in other bucket.
7. Place hose connected to intake pump into bucket with antifreeze.
8. Turn on power to unit and flush toilet until antifreeze begins to be discharged from toilet.
9. Disconnect power to toilet.

RECOMMISSIONING

1. Using buckets, hoses and approximately one gallon (3.8 liters) of clean fresh water, flush antifreeze out of the toilet (see Winterizing Instructions). Dispose of antifreeze in accordance with local and federal regulations.
2. Reconnect intake and discharge hoses and open water source valve.
3. Proceed to "System Start-Up."

SYSTEM START-UP

1. Open seacock(s).
- NOTE: Pressurized freshwater models; open water source valve.
2. Turn on power to toilet.
 3. Flush toilet per Operation Instructions.
 4. Check for leaks.

SPECIFICATIONS

Parts Included

All Complete Toilets

- Toilet Bowl
- Seat and Cover
- A7 and A8 Model
- A9 Model - Wall Switch Flush Control Panel
- Straight Discharge (except -01 models)
- Vinyl Caps (2)
- Nylon Shoulder Washer (2)

Sea Water Model

- In-Line Strainer with fittings
- Intake Pump

Pressurized Freshwater Models

- Solenoid Valve with fittings
- Atmospheric Vacuum Breaker

Additional Parts Required (minimum)

- Two stainless steel mounting bolts or lag screws (minimum 1/4" [6mm]) and washers)
- 1 1/2" (38mm) I.D. discharge hose
- 3/4" (19mm) I.D. reinforced intake hose
- 3/4" (19mm) hose clamps
- 1 1/2" (38mm) hose clamps
- Wire
- Wire Connectors
- Fuse/circuit breaker

Minimum Tools Required (will depend on fasteners)

- Screwdrivers
- Wrenches
- Drill bits
- Jig Saw
- Wire cutters
- Wire connector crimpers
- Hose cutters
- Tape measure
- Level

SPECIFICATIONS

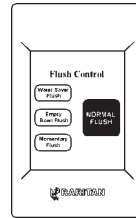

Height:
4 1/2" (11.5 cm)

Width:
2 3/4" (7cm)

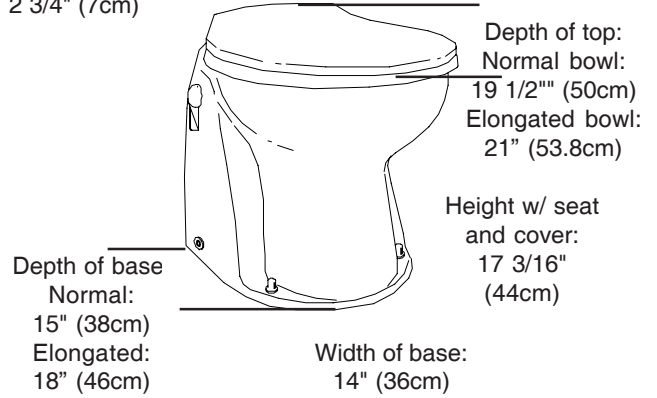

Plumbing

Pressurized water source	Minimum flow rate - 3 gallons per minute (11.3 liters per minute) Minimum pressure - 5psi (34.5 kPa)
Maximum suction of intake pump (maximum height above waterline)	4 ft. (1.2 M) from Intake Pump
Maximum height of discharge vented loop	6 ft. (1.7 M) from floor

NOTES: for Wiring

1.	Distances are from source to unit and back to source.
2.	Recommended conductor wire minimum AWG (mm ²) for 3% voltage drop.
3.	Recommended conductor sizes are based on 105°C rated insulation. Refer to ABYC Standards for other insulation ratings.
4.	For 120/240 VAC units use 24VDC specifications from transformer to unit.

Atlantes w/intake pump - Recommended Wire and Fuse/Circuit Breaker Size

Units Voltage	Circuit Breaker/fuse size (amps)	Amp. draw @ nominal voltage	15 feet	20 feet	30 feet	40 feet	50 feet
12 VDC	30	20	10 AWG	8 AWG	6 AWG	6 AWG	4 AWG
24 VDC	15	10	16 AWG	14 AWG	12 AWG	10 AWG	10 AWG
32 VDC	15	8	16 AWG	16 AWG	14 AWG	12 AWG	12 AWG

Branch to Remote intake pump (if used)	10 feet	15 feet	30 feet	40 feet	50 feet
12 VDC	14 AWG	12 AWG	10 AWG	8 AWG	8 AWG
24 VDC	16 AWG	16 AWG	16 AWG	14 AWG	12 AWG
32 VDC	16 AWG	16 AWG	16 AWG	16 AWG	14 AWG

CONVERSIONS

Wire - AWG to mm²

AWG	16	14	12	10	8	6	4	2
mm ²	1.5	2.5	4.0	6.0	10.0	16.0	25.0	35.0

Feet to Meters

Feet	10	15	20	25	30	40	50
Meter	3.1	4.6	6.1	7.6	9.2	12.2	15.2

Atlantes w/solenoid valve - Recommended Wire and Fuse/Circuit Breaker Size

Units Voltage	Circuit Breaker/fuse size (amps)	Amp. draw @ nominal voltage	10 feet	15 feet	20 feet	30 feet	40 feet	50 feet
12 VDC	15	11	12 AWG	10 AWG	10 AWG	8 AWG	6 AWG	6 AWG
24 VDC	10	5.5	16 AWG	16 AWG	14 AWG	12 AWG	10 AWG	10 AWG
32 VDC	10	4.5	16 AWG	16 AWG	16 AWG	16 AWG	16 AWG	14 AWG

Mounting Toilet

Mounting surface must be flat and solid.

1. Install seat on toilet.
2. Place toilet where it will be located.
Make sure there is room to route hoses.
Make sure seat will open properly.
3. Using a pencil, mark location of bowl mounting holes.
4. A. If hoses will be routed through floor, trace one side of toilet on floor.
 B. If hoses will be routed through wall, trace one side of toilet on wall.
5. Remove toilet and mark location for hoses on deck or wall.
6. Cut necessary holes using enclosed template through wall or floor.
7. Drill holes for toilet mounting bolts/screws.

NOTE: Use 1/4" [6mm] size bolts/screws. To select proper Screw or Bolt length, measure thickness of deck plus 1 1/8" (29mm).

TIP: Secure toilet to floor after installation is complete.

CAUTION: Do Not over tighten mounting bolts. Damage to the toilet bowl may occur. Tighten both mounting bolts evenly and slowly.

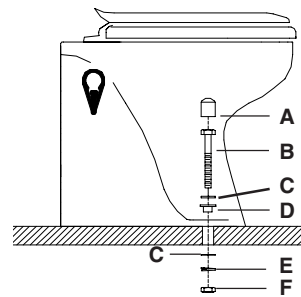
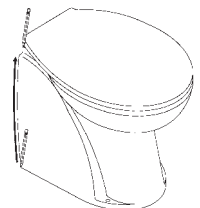
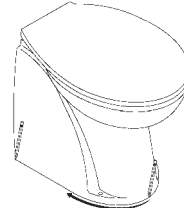
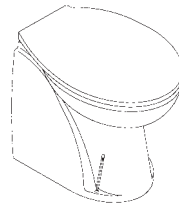
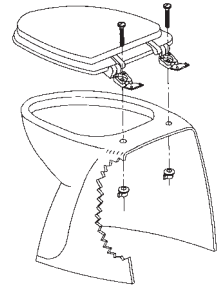
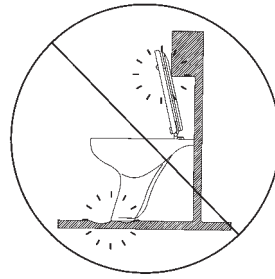

- A. Vinyl cap - #VCap (supplied)
- B. 1/4-20 S/S Bolt, or 1/4 S/S Self Tapping Screw, or 1/4 S/S Lag bolt
- C. Flat Washer, Stainless Steel
- D. Nylon Shoulder Washer - #F071 (supplied)
- E. S/S Lock washer (used on top and bottom for Nut and Bolt)
- F. 1/4-20 S/S Nut

A9 Models Only

Mounting Atlantes Wall Mounted Flush Control

IMPORTANT:

- **Locate where wires can be routed.**

NOTE: The control panel cable length is 14' (427cm)

- **Minimum depth of 2 1/2" (6.3cm) from surface is required.**

Parts Included

- Back plate assembly
- Bezel
- #4 x 1/2" screws for surface mounting (4)
- #6-32 x 7/8" screws for receptacle box mounting (2)
- Gasket

Tools Required

- Flat blade screw driver
- Level

For surface mount

- 2 1/8" (54mm) hole saw
- Drill with 5/64" (2mm) drill bit

Surface Mounting

1. Attach template provided to mounting surface. Make certain it is level.
2. Drill four 5/64" (2mm) holes.
3. Drill one 2 1/8" (54mm) hole with hole saw.
4. Install gasket on back plate.
5. Connect control panel cable (See Wiring).
6. Secure back plate to surface using #4 x 1/2" screws (4).

NOTE: Before securing back plate see J1 Jumper settings for Wall Mounted Flush Control under Changing Flush Times

7. Attach bezel to back plate.

Receptacle Box Mounting

1. Cut out surface the size of receptacle box.
2. Mount receptacle box.
3. Install gasket on back plate.
4. Connect control panel cable (See Wiring).
5. Secure back plate to receptacle using #6-32 x 7/8" screws (4).

NOTE: Before securing back plate see J1 Jumper settings for Wall Mounted Flush Control under Changing Flush Times

6. Attach bezel to back plate.

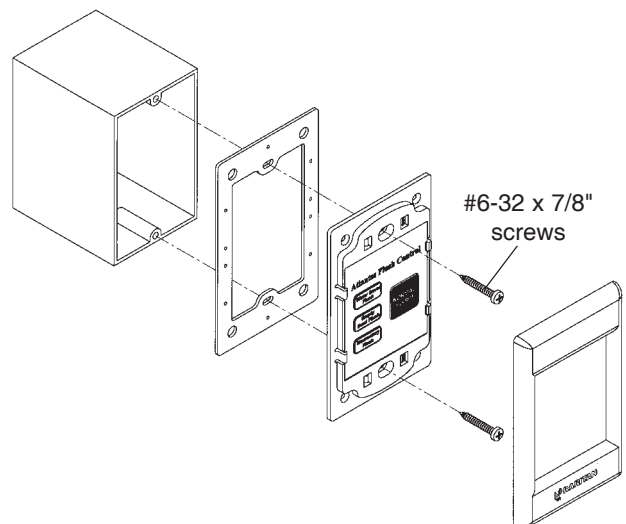
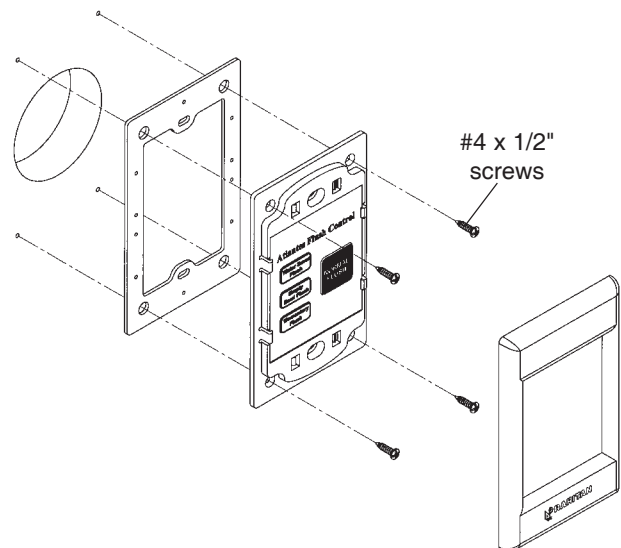
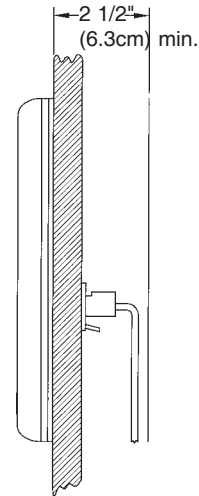

Mounting In-Line Strainer (Sea Water Models Only)

Make sure strainer bowl is tight.

1. Locate strainer where it will be accessible.
2. Mark and drill mounting holes.

NOTE: Minimum 1/4" (6mm) size bolts/screws are recommended.

3. Install fittings provided (PLA14) on strainer's inlet and outlet ports using teflon tape (included).
4. Mount strainer according to flow marking on strainer top.

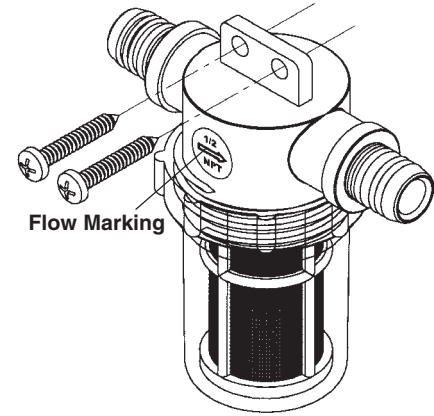

Mounting Remote Intake Pump (Remote Pump Models Only)

1. Remote intake pump must be mounted on a flat solid surface in an area that is dry and well ventilated.
2. Mark and drill mounting holes.

NOTE: Minimum 1/4" (6mm) size bolt/screws are recommended.

3. Mount pump. Do not over tighten bolts.

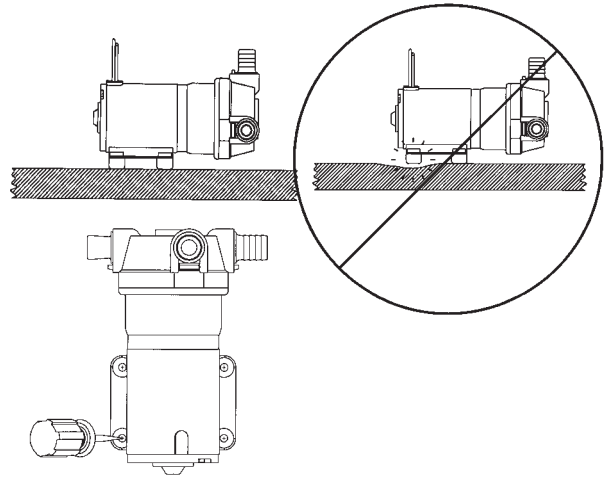

Mounting Water Solenoid Valve (Pressurized Freshwater Models Only)

1. Locate water solenoid valve on a solid flat surface in an area that is dry and well ventilated.
2. Mark and drill holes for water solenoid valve mounting bracket.

NOTE: Minimum 1/4" (6mm) size bolt/screws are recommended.

3. Mount bracket.
4. Install fittings provided (PLA14) on water solenoid valve's inlet and outlet ports using teflon tape (included).
5. Attach water solenoid valve to bracket. Hoses must be installed according to flow markings on valve body.

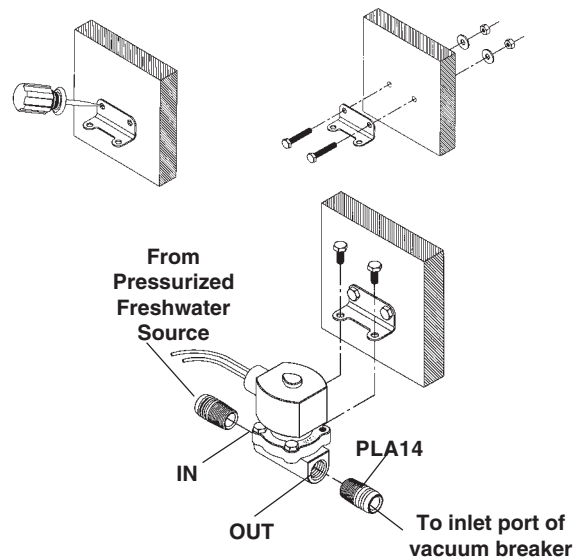

Mounting Atmospheric Vacuum Breaker (Pressurized Freshwater Model only)

1. Install fittings as shown.
2. Locate mounting area that is a minimum of 6" (15.3cm) above toilet.
3. Secure where top is in horizontal position.

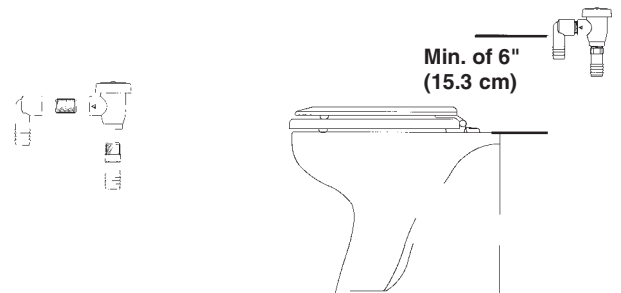

PLUMBING

WARNING: Hazard of Flooding

Toilets mounted at or below the waterline must have a vented loop installed in the discharge line. The top of the vented loop must be a minimum of 4" (10cm) above the waterline at the boat's greatest angle of heel (see vented loop manufacturer's instructions).

Sea Water Models must also have a vented loop installed between the intake pump and the toilet bowl.

Double clamp all below waterline connections.

IMPORTANT

- Fittings and 90° bends should be kept to a minimum.
 - In-Line Strainer must be installed on Sea Water Models per Installation Instructions. Failure to do so may void Warranty.
 - Discharging untreated sewage is forbidden in all U. S. waters within the three-mile limit.
 - Thru-hull fittings and seacocks must be installed where they are easily accessible.
 - Use only quality reinforced hoses.
 - Secure all hoses properly.
-
- *To retain water in bowl see section Retaining Bowl Water in installation/wiring section.*
 - *Drawings are not to scale and intended only as a general reference.*

Discharge Lines

1. Connect quality 1 1/2" (38mm) I.D. sanitation hose to discharge fitting.
2. Run hose to appropriate Marine Sanitation Device.

NOTE: Discharge hose runs longer than 16 feet (4.9m) should install a vented loop near toilet to force waste beyond vented loop to drain by gravity.

Atlantes with Integral Pump and Atlantes Deodorant System installed above waterline.

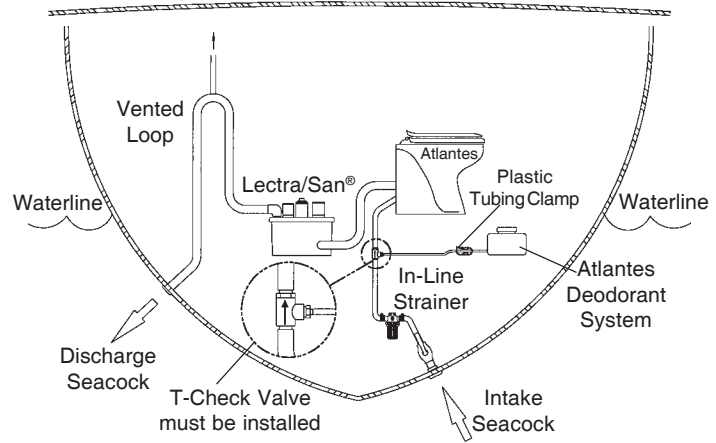

Atlantes with Remote Intake Pump installed below waterline.

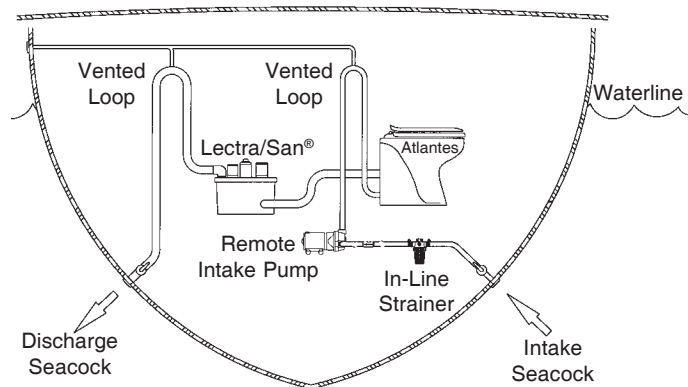

Atlantes with Water Solenoid Valve (#A5F* or A6F*) for water system connection with holding tank.

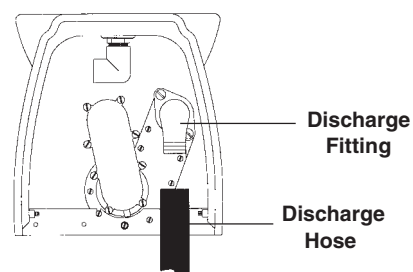
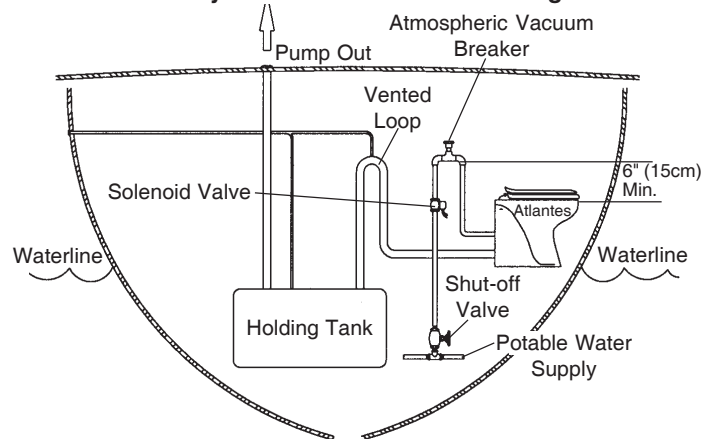

Intake Lines

Pressurized Freshwater Models

WARNING: Hazard of potable water contamination. An atmospheric (anti-siphon) vacuum breaker must be used with any installation using a potable water source.

Install a shut off valve in intake line before water solenoid valve.

1. Connect hose from shut off valve to inlet port of water solenoid valve.

NOTE: To avoid malfunction of water solenoid due to debris in water, installation of Freshwater Strainer (190601) is recommended.

2. Connect hose from outlet port of water solenoid valve to inlet port of vacuum breaker.
3. Connect hose from outlet port of vacuum breaker to bowl elbow.

NOTE: Vacuum breaker must be last mechanical component before bowl elbow.

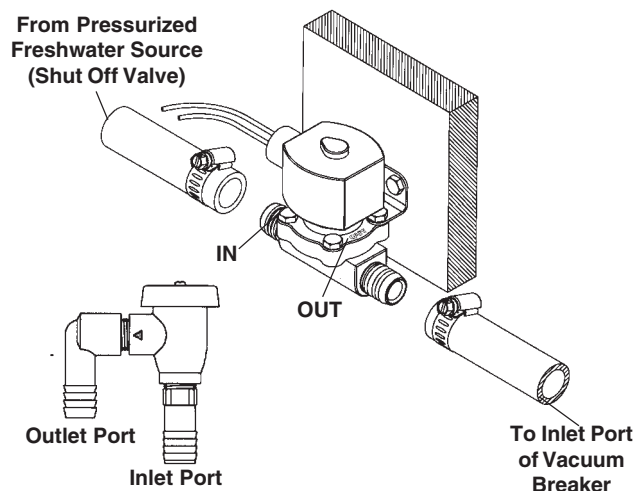

Sea Water Models

Intake pump fittings are interchangeable to allow more flexibility during installation. Inlet ports are located on either side of intake pump. Outlet port (to toilet bowl) is at top of intake pump.

1. Slide fitting clips to open position.
2. Select inlet port to be used. (Integral models - only one port is available)
3. Install appropriate fittings into inlet and outlet ports.

NOTE: The 90° fitting can be rotated 360°.

4. Install the plug fitting into unused inlet port. (Integral models - plug is pre-installed)

IMPORTANT: Be sure not to install plug fitting into outlet port! Damage will occur!

5. Slide fitting clips back to closed position.
6. Connect hose from seacock to inlet port of In-Line Strainer. Use hose clamp provided.
7. Connect hose from outlet port of In-Line Strainer to inlet port of intake pump. Use hose clamp provided.

IMPORTANT: Double clamp all below waterline hose connections!

Remote Pump Models - Connect hose from outlet port of intake pump to bowl elbow located on back of toilet bowl. (Integral pump model is already connected).

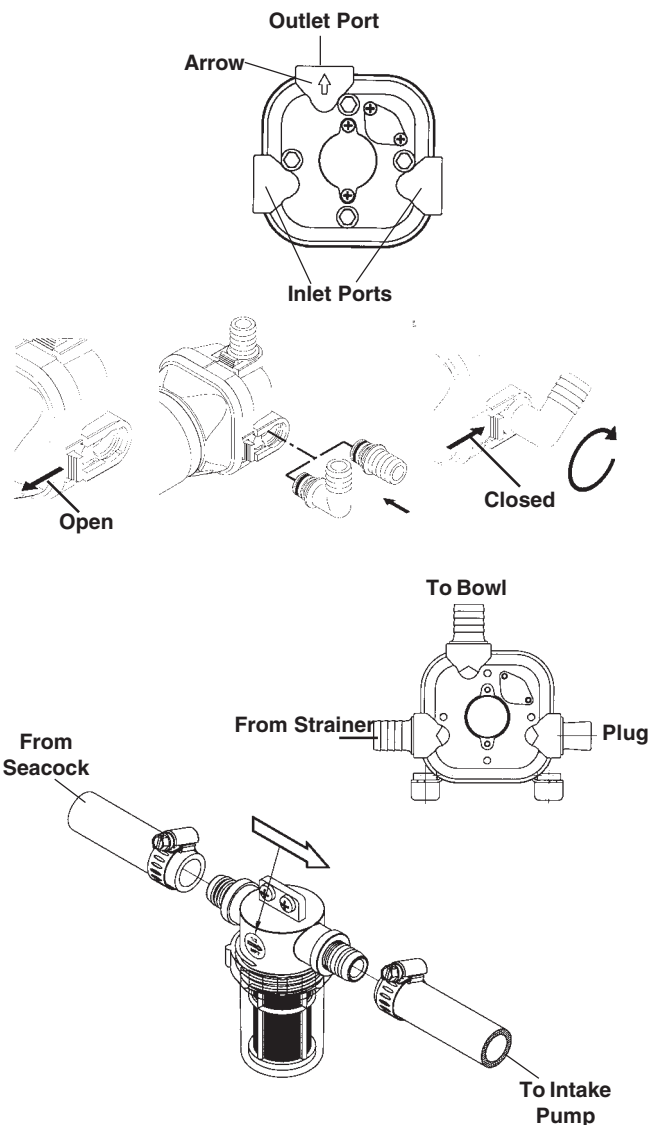

WIRING

WARNING: Hazard of Shock and Fire

- Always use proper wire and fuse/circuit breaker. See Specification Chart.
- Secure wire properly.
- Do not connect appliances to toilet circuit.
- Make sure power is off before proceeding.
- Use proper wire terminals for all wire connections.

1. Determine proper wire size by measuring distance from power source to toilet motor back to power source.
2. Select proper gauge wire and fuse/circuit breaker size from Specifications.
3. Install fuse/circuit breaker in positive line at source.
4. Connect positive wire from fuse/circuit breaker to red (POS) at rear of bowl.
5. Connect wire from battery negative or power source ground buss to black (NEG) at rear of bowl.

Remote Intake Pump:

- Connect red and black 8 AWG wire at back of bowl labeled remote pump - red wire (POS) to orange wire and black wire (NEG) to black wire of remote intake pump.

Pressurized Freshwater Solenoid Valve:

- Connect black and orange 16 AWG wire from back of bowl to water solenoid valve. Water solenoid is not polarity sensitive.

120/240 VAC Units:

- For proper wire gauge and circuit breaker from Transformer (#RTAH24D) to unit refer to 24 VDC specifications. To connect power to transformer refer to Installation Instructions included with #RTAH24D.

Atlantes with Wall mounted Flush Control Panel (A9 Models):

- Unroll cable from toilet control and route to opening on the wall. Attach cable to the back of Atlantes Wall mounted Flush Control Panel. Secure cable every 18 inches (46cm). Do not damage insulation.

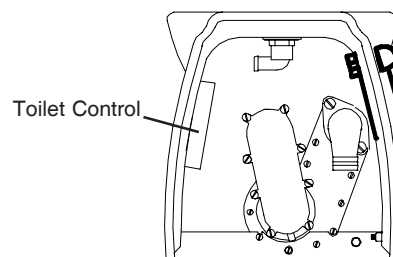
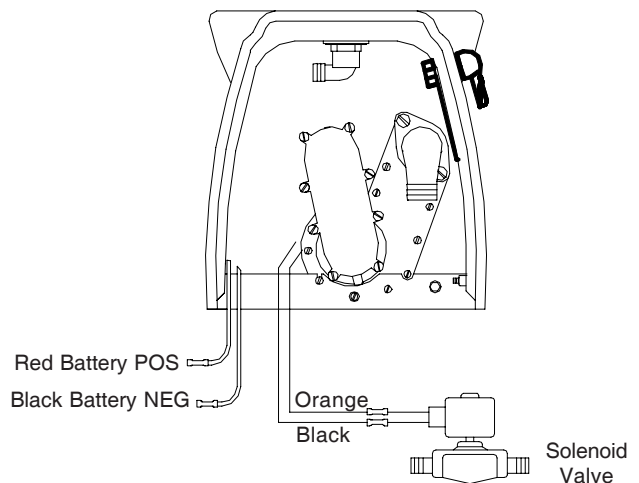
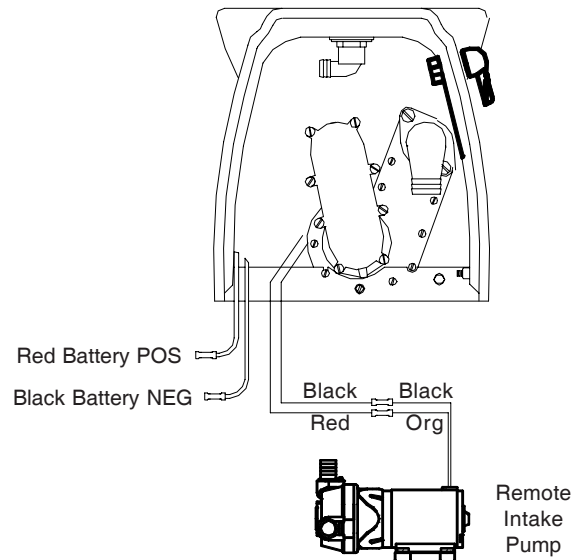
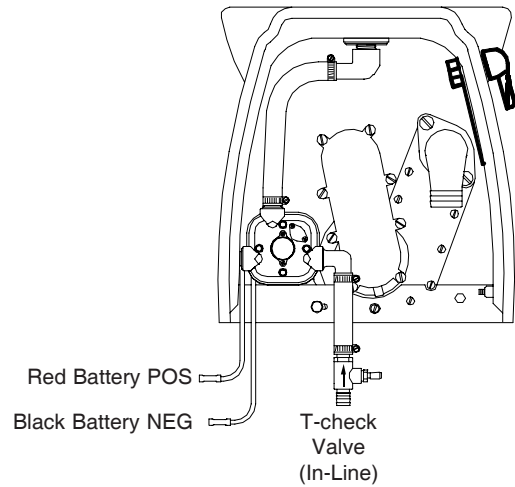

Retaining Bowl Water

Flush Lever Toilets (A8 Models):

NOTE: A discharge vented loop **MUST** be installed to retain water in the bowl.

- To retain water in bowl turn extend flush switch ON (located on Toilet Control).
- Inlet pump will continue to run a few seconds after discharge pump has stopped.
- Unit with factory installed internal vented loop is preset to ON position.

CHANGING FLUSH TIMES

Flush Lever Toilets (A8 Models):

- The normal flush is factory pre-set for approximately 10 seconds.
- Installations that require longer flush times can be changed by setting switch number 2 and 3 per flush time adjustment chart

Retaining Bowl Water

Wall Switch Flush Control Panel (A9 Models):

NOTE: A discharge vented loop **MUST** be installed to retain water in the bowl.

- To retain water in bowl set switch 1 of J1 to ON. Intake pump will continue to run a few seconds after discharge pump has stopped.

Changing Flush Time

Wall Switch Flush Control Panel (A9 Models):

- Normal flush can be set to flush for 10, 12, 14 or 16 seconds by setting switches 2 and 3 located behind the wall switch flush control panel. Water Saver Flush will be half of the time set by these jumpers.

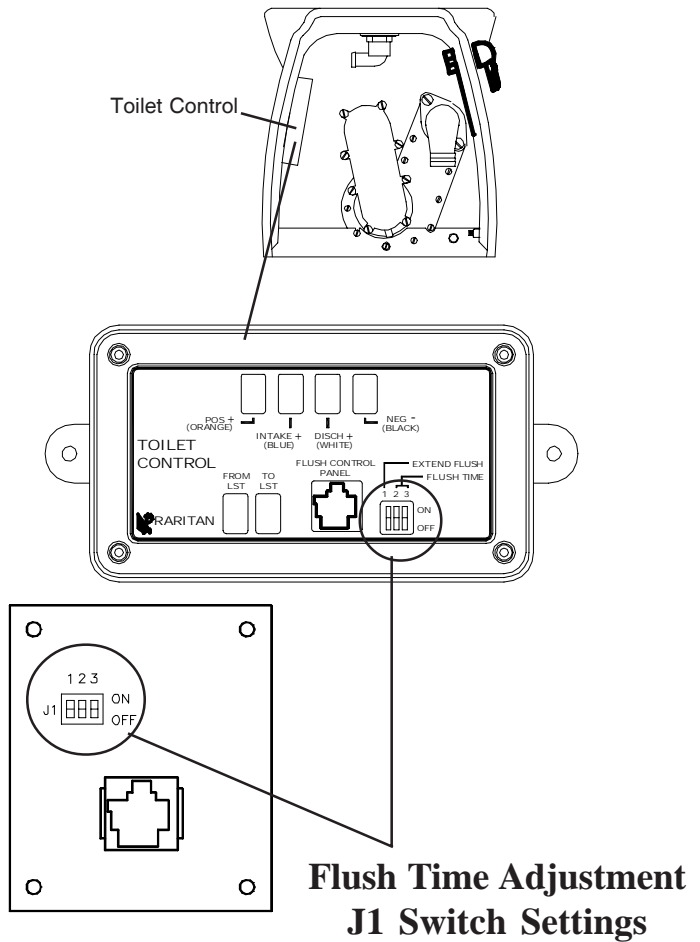

**Flush Time Adjustment
J1 Switch Settings**

SW ITCH NUMBER		FLUSH TIME SECONDS
2	3	
ON	ON	10
ON	OFF	12
OFF	ON	14
OFF	OFF	16

Upgrading from A7 to A8:

1. Turn off power
2. Remove mounting screws and slide bowl forward slightly
3. Locate and gently pull the 4 wires for the toilet control leaving some slack to make connections
4. Install all four wires on toilet control following the correct color code
5. Set timer to desired settings - see changing flush times
6. Check operation by turning on power
7. Install box in place by pressing firmly reclosable fastener
8. Mount the bowl



Unit does not activate or flush:

- **No power to unit**
Check main circuit breaker/switch
check wiring to unit
- **Overload/jammed discharge**
Reset A9 model by turning off power
if unit runs for few second only and
stops again see “how to clear jam/clog”

Unit runs as soon as power is turned on:

- **Reversed polarity**
Check and correct polarity
- **Stuck handle**
Make sure handle is not stuck in on position
- **Failed timer control**
Disconnect timer control and check
(see replacing timer)

Bowl does not retain water:

- **A vented loop (external or internal is required to retain water in the bowl)**
- **Check jumper settings for extended flush**
- **Clogged vent**
check and clear vent in the loop
- **Water in the vent line**
ventline must be run to avoid dips or low spots

Poor or no flow from rim of the bowl:

- **Clogged intake strainer**
check and clean strainer basket
- **Air leak in suction line**
repair
- **No activation of inlet pump/solenoid**
Check if pump or solenoid has power
replace or repair if power but no activation

Bowl fills up/ poor discharge out of bowl

- **Low voltage below 11.5V**
- **Clogged discharge pump**
See “how to clear Jam/clog”
- **Clogged discharge line/clogged vent**
check and repair
- **Failed water solenoid**
Check if water solenoid shuts off
completely, repair if needed

Replacing/checking toilet control:

1. Turn off power
2. Remove mounting screw and slide bowl forward slightly
3. Remove control from reclosable fastner
4. Pull box out until all wires are accessible
5. Disconnect wires using needle nose pliers, do not pull on wires, pull connectors
6. Install new control
7. Check operation by turning on power
8. Install box in place by pressing firmly on reclosable fastner
9. Mount the bowl



How to clear Jam/clog

A7 Model:

- Disconnect POS and NEG wires from unit
- Connect NEG to POS and POS to NEG
- Push handle back until discharge starts to run
- Repeat several times, this causes motor to run in reverse and should clear most clog's
- Reconnect NEG to NEG and POS to POS

A8 and A9 models:

- Disconnect POS and NEG wires
- Connect NEG wire to POS from battery
- **MOMENTARILY** connect POS from toilet to NEG from battery until discharge starts running
- Reconnect NEG to NEG and POS to POS

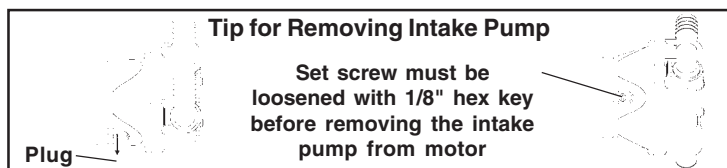

EXPLODED PARTS

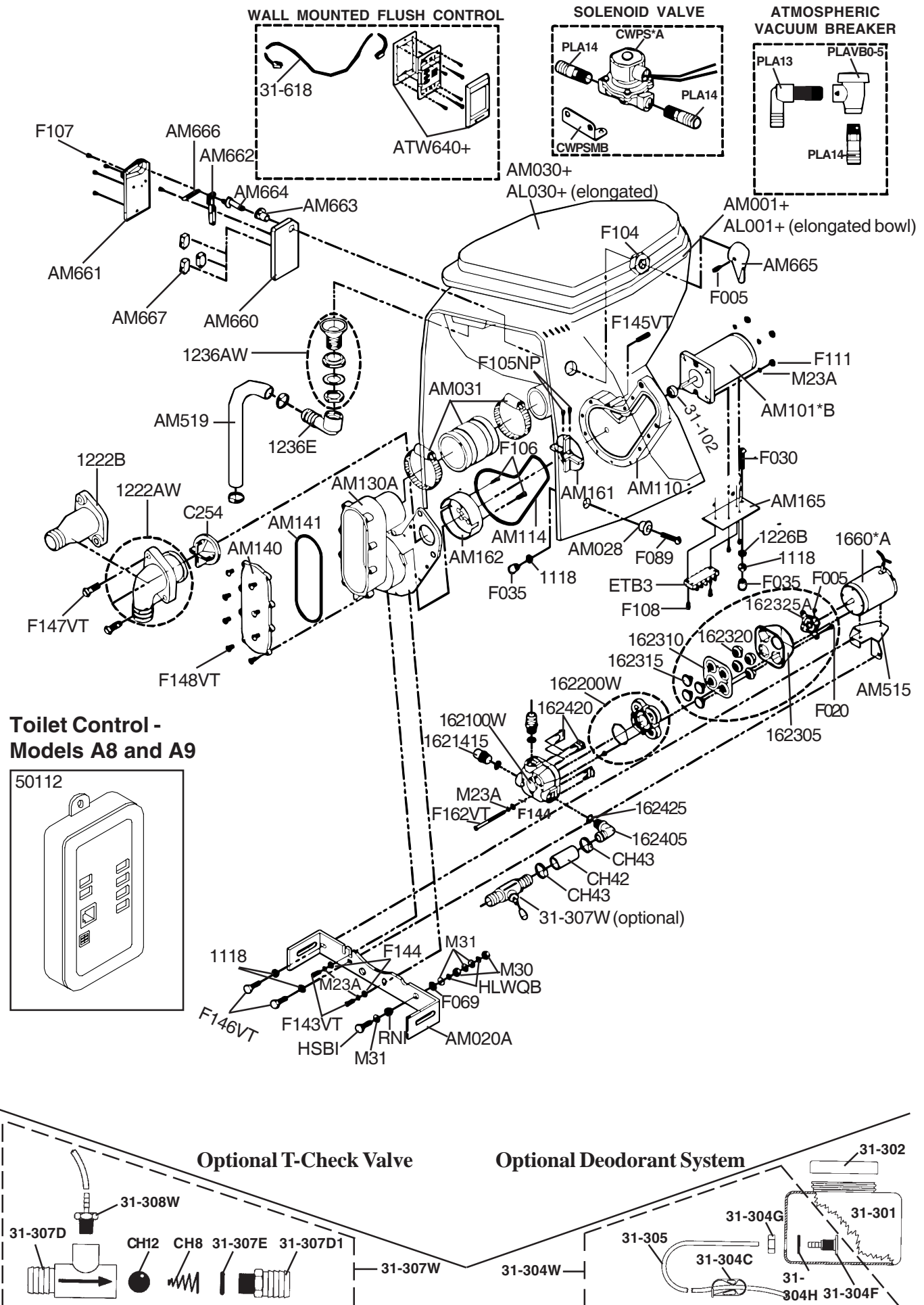

PARTS LIST

PART #	DESCRIPTION
1118(4)	1/4" Locking Star Washer
1119(2)	1/4-20 x 3/4" Hex screw
1222AW	90° Discharge w/Flange
1222B	Straight Discharge
1226B(2)	1/4-20 Nut S/S
1236AW	Spud Assembly
1236E	Bowl Elbow
162100W	Upper Housing Assembly
162135(4)	Cone Seal
162200W	Middle Housing Assembly
162225	O-Ring
162300W	Lower Housing Assembly
162305	Lower Housing
162310	Diaphragm
162315	Piston (4)
162320	Piston Seat (4)
162325A	Bearing Plate Assembly
162405	3/4" Hose Barb 90° Fitting
162410	3/4" Hose Barb Straight
162415	Plug Fitting
162420 (3)	Fitting Clip
162425	O-Ring
1660*A	Pump Motor
31-102	Motor Shaft Seal
41-260	Bowl Elbow (Freshwater Units not shown)
AM001+	Atlantes Bowl (white)
AL001+	Atlantes Elongated Bowl (white)
AM020B	Pump Mounting Bracket
AM028	Bushing
AM030+	Atlantes Seat & Cover (white)
AM031	Discharge Connection (3 pieces)
AM101*B	Motor
AM110	Discharge Pump Back
AM114	Discharge Pump "O" Ring
AM130A	Discharge Pump Body
AM140	Discharge Cover
AM141	Discharge Cover O-Ring
AM161	Grinder Impeller
AM162	Grinder Teeth
AM165	Terminal Block Bracket
AM203	Remote Inlet Pump Base (not shown)
AM515	Atlantes Pump Mounting Bracket
AM519	Intake Hose from diaphragm pump
C254	Joker Valve
CH42 (2)	3/4" Reinforced Hose
CH43(5)	Hose Clamp S/S
ETB3	Terminal Block
F005(2)	1/4-20 x 5/16 SS Hex SOC
F030	1/4-20 x 2" Rnd. Hd. Screw S/S
F035(3)	Isolation Nut
F069	1/4" Fiber Washer
F071	Nylon Shoulder Washer (not shown)
F089(2)	1/4-20 x 1 3/4" Rnd. Hd. Screw S/S
F104	Panel Nut Brass Hex 5/8-32 x 7/8 x 1/8
F105NP(2)	1/4-28 set screw with nylon patch
F106	Plastite screw #6 x 3/4
F108	Screw #4 x 1
F111(4)	10-32 S/S Nut
F112(2)	8-32 x 1/4" Screw
F142VT(8)	10-32 x 5/8" Pan Hd. S/S Screw (not shown)
F143VT(2)	10-32 x 1" Pan Hd. SLTD S/S Screw
F144(2)	#10 S/S Flat Washer
F145VT(1)	10-32 x 1 3/4" Pan Hd. SLTD S/S Screw
F146VT(2)	1/4-20 x 1 1/4" Rnd Hd. Screw S/S W/VT
F147VT(2)	3/8-16 x 1 1/2" Rnd Hd. Screw S/S
F148VT(8)	8-32 x 7/16" S/S Truss Hd. Screw
F162VT	Mounting Bolt
HLWQB(4)	1/4" Split Lock Washer
HSB1(2)	1/4-20 Brass Screw
M23A(19)	#10 Lockwasher S/S
M30(4)	1/4-20 Brass Nut
M31(8)	1/4" Brass Flat Washer
RNI	Nylon Shoulder Washer
RTAH24D	Transformer/Rectifier for 120/240 VAC (not shown)

WALL MOUNTED FLUSH CONTROL

1226A	1/4-20 X 1 1/4" Rnd. Hd. Screw S/S
31-618	Cable for Flush Control (14 ft.)
AM028	Bushing
ATW*	Flush Control PCB Assy.
ATW640	Flush Control with Bezel Back Plate (White)
ATW640A	Flush Control with Bezel Back Plate (Bone)
ATW640B	Flush Control with Bezel Back Plate (Black)
F153	#4 1/2 Oval slotted
F170	6/32 - 7/8" screw

SOLENOID VALVE

CWPS*A	1/2" GC Solenoid Valve
CWPSMB	Mounting Bracket for CWPS*
PLA14 (2)	1/2" MPT to 3/4" Barbed Nipple
ATMOSPHERIC (ANTI-SIPHON) VACUUM BREAKER	
PLA13	1/2" NPT to 3/4" Hose Elbow
PLA14	1/2" MPT to 3/4" Barbed Nipple
PLAVB0-5	Atmospheric (anti-siphon) Vacuum Breaker

OPTIONAL T-CHECK VALVE PARTS LIST

31-307D	Valve Body
31-307D1	Outlet Adapter
31-307E	"O" Ring
31-307W	T-Check Valve Assembly Complete
31-308W	Siphon Check Valve
CH8	Check Valve Spring
CH12	Check Ball
OPTIONAL DEODORANT/SALT FEED PARTS LIST (ADS)	
31-301	Salt Feed Tank
31-302	Salt Feed Tank Cap
31-304C	Plastic Tubing Clamp
31-304F	Bulkhead Fitting
31-304G	Bulkhead Fitting Nut
31-304H	Bulkhead Fitting Seal
31-304W	Assembly (includes part #'s 31-304C, 31-304F, 31-304G, 31-304H, 31-305)
31-305	PVC Clear Tubing 1/4"

ADDITIONAL ACCESSORIES AVAILABLE FROM RARITAN

1PCP22	C.P., Cleans Potties, Bio-enzymatic, 22 oz.
AHDA1W	Internal Vented Loop
CON22	Raritan Concentrate 22 oz. bottle
SH	Sanitation Hose (sold by the foot)
VL 1 1/2	Vented Loop 1 1/2"
VL 3/4	Vented Loop 3/4"
YV	"Y" Valve

§Parts are NOT included with Wall Switch Flush Control Models

+CHOICE OF COLOR

*SPECIFY VOLTAGE

NOTES

LIMITED WARRANTY

Raritan Engineering Company warrants to the original purchaser that this product is free of defects in materials or workmanship for a period of one year from the product's date of purchase. Should this product prove defective by reason of improper workmanship and/or materials within the warranty period, Raritan shall, at its sole option, repair or replace the product.

1. TO OBTAIN WARRANTY SERVICE, Consumer must deliver the product prepaid, together with a detailed description of the problem, to Raritan at 530 Orange St., Millville, N.J. 08332, or 3101 SW 2nd Ave. Ft. Lauderdale, FL 33315. When requesting warranty service, purchaser must present a sales slip or other document which establishes proof of purchase. **THE RETURN OF THE OWNER REGISTRATION CARD IS NOT A CONDITION PRECEDENT OF WARRANTY COVERAGE.** However, please complete and return the owner Registration Card so that Raritan can contact you should a question of safety arise which could affect you.
2. **THIS WARRANTY DOES NOT COVER** defects caused by modifications, alterations, repairs or service of this product by anyone other than Raritan; defects in materials or workmanship supplied by others in the process of installation of this product; defects caused by installation of this product other than in accordance with the manufacturer's recommended installation instructions or standard industry procedures; physical abuse to, or misuse of, this product. This warranty also does not cover damages to equipment caused by fire, flood, external water, excessive corrosion or Act of God.
3. **ANY EXPRESS WARRANTY NOT PROVIDED HEREIN, AND ANY REMEDY FOR BREACH OF CONTRACT WHICH BUT FOR THIS PROVISION MIGHT ARISE BY IMPLICATION OR OPERATION OF LAW, IS HEREBY EXCLUDED AND DISCLAIMED. ALL IMPLIED WARRANTIES SUCH AS THOSE OF MERCHANTABILITY AND OF FITNESS FOR A PARTICULAR PURPOSE, IF APPLICABLE, AS WELL AS ANY IMPLIED WARRANTIES WHICH MIGHT ARISE BY IMPLICATION OF LAW, ARE EXPRESSLY LIMITED TO A TERM OF ONE YEAR. SOME STATES DO NOT ALLOW LIMITATIONS ON HOW LONG A LIMITED WARRANTY LASTS, SO THE ABOVE LIMITATION MAY NOT APPLY TO YOU.**
4. **UNDER NO CIRCUMSTANCES SHALL RARITAN BE LIABLE TO PURCHASER OR ANY OTHER PERSONS FOR ANY SPECIAL OR CONSEQUENTIAL DAMAGES, WHETHER ARISING OUT OF BREACH OF WARRANTY, BREACH OF CONTRACT, OR OTHERWISE. SOME STATES DO NOT ALLOW THE EXCLUSION OR LIMITATION OF INCIDENTAL OR CONSEQUENTIAL DAMAGES, SO THE ABOVE LIMITATION OR EXCLUSION MAY NOT APPLY TO YOU**
5. No other person or entity is authorized to make any express warranty, promise or affirmation of fact or to assume any other liability on behalf of Raritan in connection with its products except as specifically set forth in this warranty.
6. This warranty gives you specific legal rights, and you may also have other rights which vary from state to state.



530 Orange Street Millville, NJ 08332 USA
Telephone: 856-825-4900 FAX: 856-825-4409
www.raritaneng.com
3101 SW Second Avenue, Fort Lauderdale, FL 33315 USA
Telephone: 954-525-0378 FAX: 954-764-4370