

BRONZE PEDESTAL ROTARY GEAR PUMPS



OBERDORFER PUMPS
A Subsidiary of Thomas Industries Inc.

MODELS
N11500-21
N11510-21

1 1/4" NPT PORTS



MODEL N11500-21- UPPER DRIVE
MODEL N11510-21 - LOWER DRIVE

FEATURES

- g Bronze Corrosion Resistant Castings
- g Stainless Steel Shafts & Fasteners
- g Self-Lubricating Carbon Bearings
- g Packing (Braided Acrylic yarn with special lubricant and Graphite)
- g For Mechanical Seals, see Models N11HDM

DRIVE

Either direct drive with flexible coupling or pulley drive can be used. For pulley driven pumps a pillow block bearing must be used at the drive shaft end to absorb the belt forces. The drive shaft is sufficiently long enough to accommodate a pillow block in addition to the pulley.

Correct alignment is absolutely essential for satisfactory pump life. Recheck alignment after the piping has been connected to the pump.

LIQUIDS AND TEMPERATURE

Service life will be increased substantially if the liquid pumped is clean and has a lubricity value. These pumps have extremely close tolerances. Fine abrasives like sand, silt, or powders in suspension will destroy pumping ability.

Liquids compatible with bronze, stainless steel and the acrylic graphite packing can be pumped. Solvent resistant packings and Teflon(R)* packings are also available. See a chemical compatibility table or check factory. When possible, flush the pump with water after using.

Temperature extremes are detrimental to service life and should be avoided. Basic metals of construction allow temperature range of -40°F to 400°F. the acrylic graphite packing is rated to 500 °F. Freezing liquid in the pump can deform or damage the pump.

Viscous liquids such as molasses or oils require a lower pump speed, in extreme cases as low as 200 R.P.M. Consult factory for recommended speeds and increased horsepower requirements.

*Teflon(R) is a registered trademark of DuPont. Teflon(R) or equivalent PTFE will be used.

CAPACITY Water 60°F

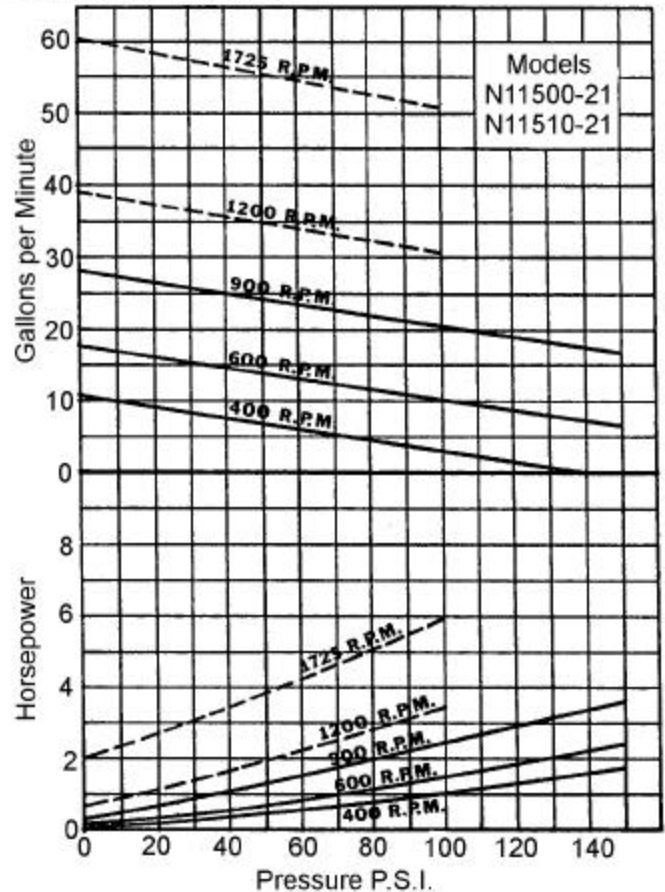

Note: Dotted lines(---) recommended for intermittent duty only due to accelerated wear at higher speeds and pressures.

Large suction lines are required to prevent cavitation which can cause pump destruction.

Liquids with specific gravities heavier than water such as dry cleaning fluids require an increase in motor horsepower directly proportional to the increase in specific gravity over water.

SUCTION LIFT

A rotary gear pump is capable of lifting water on the suction side as high as 20 feet. Though gear pumps are self-priming, a foot valve is recommended. For pumping water directly from streams or ponds, a wire mesh strainer must be used at the beginning of the suction line to prevent stones from entering the pump. Strainer and foot valve are commercially available as combination units.

ROTATION

N11510-21

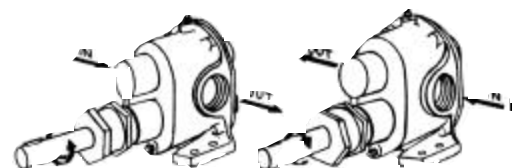

MODELS
N11500-21
N11510-21

BRONZE PEDESTAL ROTARY GEAR PUMPS

OBERDORFER PUMPS
A Subsidiary of Thomas Industries Inc.

EXPLODED VIEW AND PARTS LIST

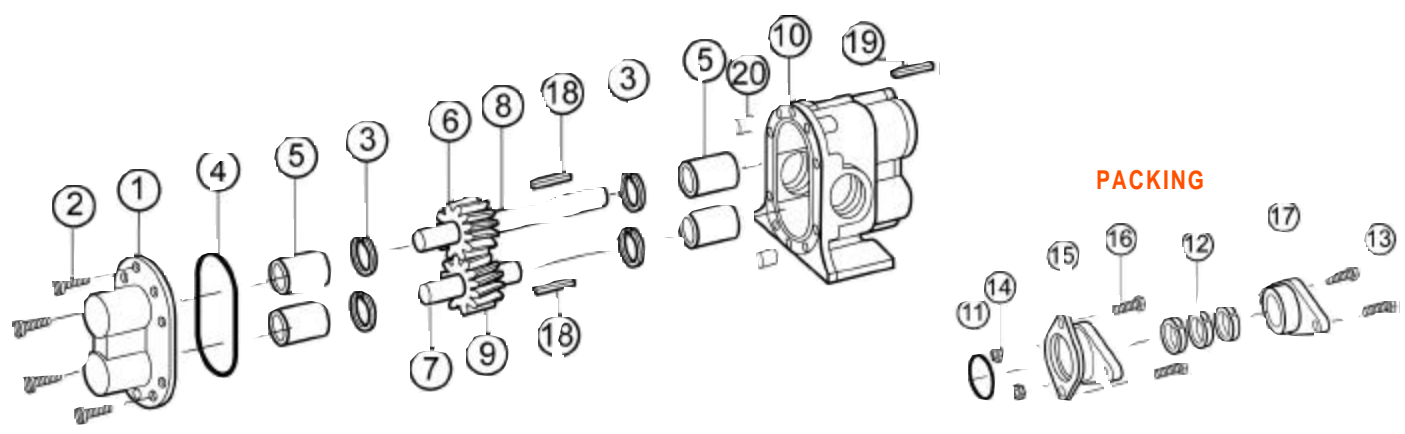

| Pump No. | 1 | 2 | 3 ¹ | 4 ¹ | 5 ¹ | 6 ¹ | 7 ¹ | 8 ¹ | 9 ¹ | 10 |
|-----------|----------|---------|----------------|----------------|----------------|----------------|----------------|----------------|----------------|----------|
| | Cover | Screw | Snap Ring | O-Ring | Bearing | Drive Gear | Idle Shaft | Drive Shaft | Idle Gear | Body |
| | 1 Req'd | 8 Req'd | 4 Req'd | 1 Req'd | 4 Req'd | 1 Req'd | 1 Req'd | 1 Req'd | 1 Req'd | 1 Req'd |
| N11500-21 | 9333NN5N | 5393 | 7651 | 9797-158 | 5108 | 9833 | 7652 | 5685 | 9834 | 9331NG7N |
| N11510-21 | 9333NN5N | 5393 | 7651 | 9797-158 | 5108 | 9833 | 7652 | 5685 | 9834 | 9331NG8N |

| Pump No. | 11 | 12 ¹ | 13 | 14 | 15 | 16 | 17 | 18 ¹ | 19 | 20 | Repair Kit |
|-----------|---------|-----------------|---------|---------|---------|---------|--------------|-----------------|---------|-----------|------------|
| | O-Ring | Packing | Screw | Nut | Gland | Screw | Seal Adapter | Key | Key | Dowel Pin | |
| | 1 Req'd | 3 Req'd | 2 Req'd | 2 Req'd | 1 Req'd | 2 Req'd | 1 Req'd | 2 Req'd | 1 Req'd | 2 Req'd | |
| N11500-21 | 6515 | 7624 | 5916 | 8395 | 7451 | 9905 | 9904 | 6518 | 5576 | 8597 | 10642 |
| N11510-21 | 6515 | 7624 | 5916 | 8395 | 7451 | 9905 | 9904 | 6518 | 5576 | 8597 | 10642 |

¹Repair Kits contain items 3,4,5,6,7,8,9,12 and 18.

DIMENSIONS

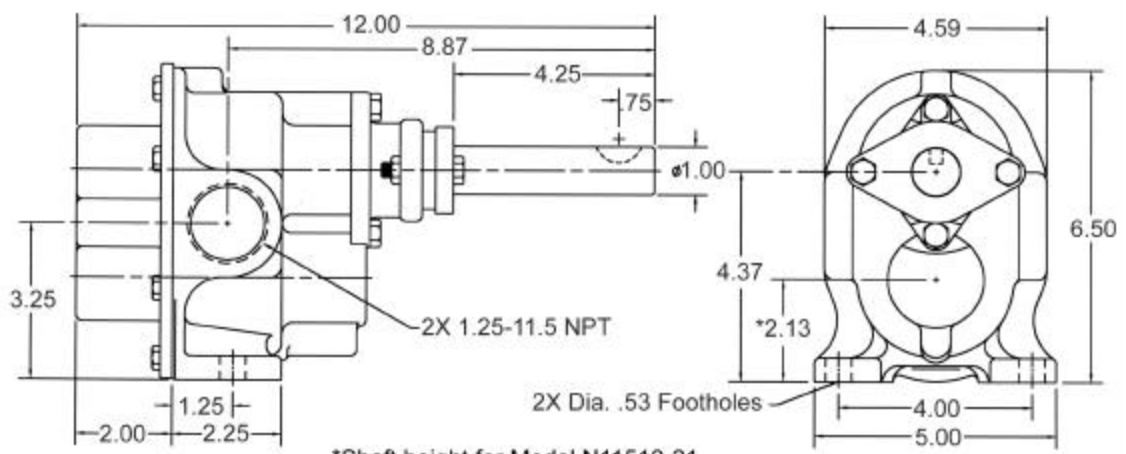

*Shaft height for Model N11510-21.