

# FLANGE MOUNTED HIGH PRESSURE ROTARY GEAR PUMP

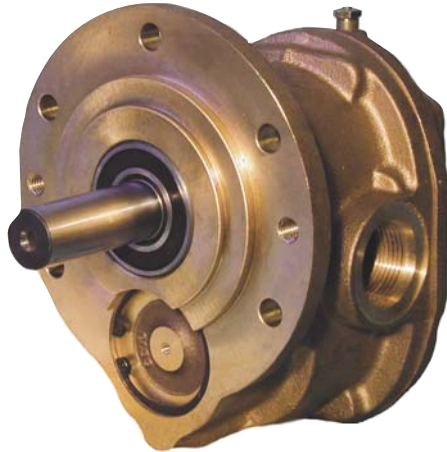

## FEATURES

- Bronze construction
- Hardened stainless steel shafts
- Stainless drive gear, bronze idle gear
- Heavy duty, grease lubricated, hardened steel, ball and roller bearings
- Double row ball bearings for drive shaft provide added support for belt pulley loads
- Grease lubrication fittings, grease vent relief fittings, grease drain plug
- 1 5/16 -12 JIC ports
- Stainless caged, teflon wedge reinforced, viton lip seals
- Integrated seal relief ports at suction side
- Removable rear end plate for ready bearing inspection
- Rear cover with threaded jack bolt holes for easy removal
- Removable lower front cover for access to idle bearing

## GENERAL DESCRIPTION

This rugged pump incorporates grease lubricated ball bearings and roller bearings isolated from the pump fluid via viton lip seals.

Also available with sealed bearings, pedestal mounting pads, and belt drive electric clutch actuators. (see 110-12)

External rotary gear pumps are positive displacement pumps. Each shaft revolution displaces a definite amount of liquid relatively unaffected by the back pressure in the discharge line. shaft speed and flow are directly proportional.

## DRIVE ARRANGEMENT

Given the suction side seal relief port orientation, these pumps are unidirectional. Shaft rotation is counter clockwise

## PERFORMANCE

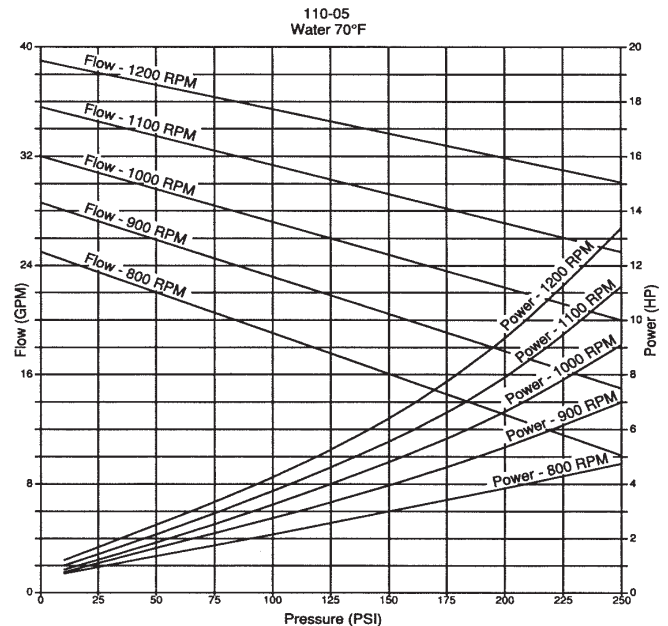

when viewing the pump from the drive shaft end. Maximum design speed is 1200 RPM.

## LIQUIDS AND TEMPERATURE

These pumps are suitable for all liquids that are compatible with bronze. Most common liquids are water, oil, and mild chemicals in the pH-range of 4 to 11. Viscous liquids require reduced shaft speeds of 1150 RPM or lower. Consult factory.

Liquids containing solids, abrasives, powders or paint pigments are definitely not recommended for gear pumps. If abrasives are unavoidable, use a very low shaft speed. The recommended liquid temperature range is 32° to 140°F for longest pump life. If more extreme temperature conditions exist, our factory should be consulted. Freezing of water-filled pumps can cause damage and must be avoided. Oils at low temperatures are very viscous requiring a lower speed or extra power.

## SUCTION LIFT

As a general rule, the suction lift should be kept at an absolute minimum by placing the pump as close to the liquid as possible. A gear pump in new condition can lift 20 feet of water in the suction line. A foot valve (preferably with a built-in strainer) is recommended at the beginning of the suction line. For a first start-up, the pump should be primed to avoid dry running. Minimum size of the suction pipe is the size of the pump inlet port. For longer suction lines (over 3 feet), or for viscous liquids, the pipe size should be at least one size or two sizes larger than the pump inlet port.

\*Viton® is a registered trademark of DuPont Dow Elastomers. Viton® or equivalent FKM will be used.  
Teflon® is a registered trademark of DuPont. Teflon® or equivalent PTFE will be used.

**FLANGE MOUNTED  
HIGH PRESSURE  
ROTARY GEAR PUMP**

**EXPLODED VIEW AND PARTS**

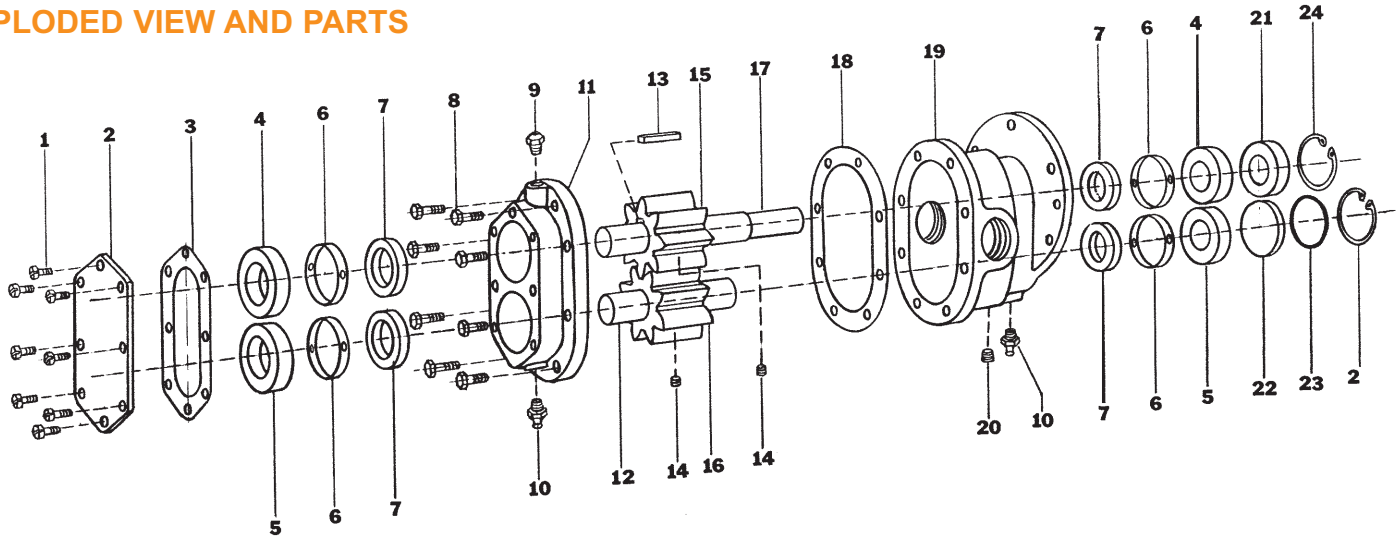

	1	2	3	4	5	6	7	8	9	10	11	12
	Screw, FilHd	End Plate	Gasket, End Plate	Ball Brg, Open	Roller Brg	Spacer	Lip Seal	Screw, HexHd	Relief Fitting	Grease Fitting	Cover	Idle Shaft
Pump No.	Qty. 8.00	Qty. 1.00	Qty. 1.00	Qty. 2.00	Qty. 2.00	Qty. 4.00	Qty. 4.00	Qty. 8.00	Qty. 1.00	Qty. 2.00	Qty. 1.00	Qty. 1.00
110-05	5385	6509	6517	6503	6689	6955	6915	5670	6669	5390	6506	6512

	13	14	15	16	17	18	19	20	21	22	23	24	Repair Kit
	Key	Set Screw	Drive Gear	Idle Gear	Drive Shaft	Gasket Pump	Body	Pipe Plug	Ball Brg, Sealed	Brg Cover	O-Ring	Ret. Ring	
Pump No.	Qty. 1.00	Qty. 2.00	Qty. 1.00	Qty. 1.00	Qty. 1.00	Qty. 1.00	Qty. 1.00	Qty. 1.00	Qty. 1.00	Qty. 1.00	Qty. 1.00	Qty. 2.00	
110-05	6518	6193	6800	6510	6511	6516	6501	6052	6504	6673	6672	6513	12252

Repair Kits contain items 3, 5, 7, 12, 13, 14, 15, 16, 17, 18, 23 & 24

**DIMENSIONS**

