



**ELETTROPOMPA AUTOADESCANTE
PER TRAVASO LIQUIDI
SELF-PRIMING ELECTRIC PUMP
FOR TRANSFERRING VARIOUS LIQUIDS**

**AVVERTENZE D'USO
INSTRUCTIONS FOR USE**

**164 103 12 - UP9-XA 12 V
164 103 13 - UP9-XA 24 V**



DIAGRAMMA PORTATA FLOW RATES DIAGRAM



DIAGRAMMA ASSORBIMENTI AMPERE-DRAW DIAGRAM



PRODUCT DESCRIPTION

A

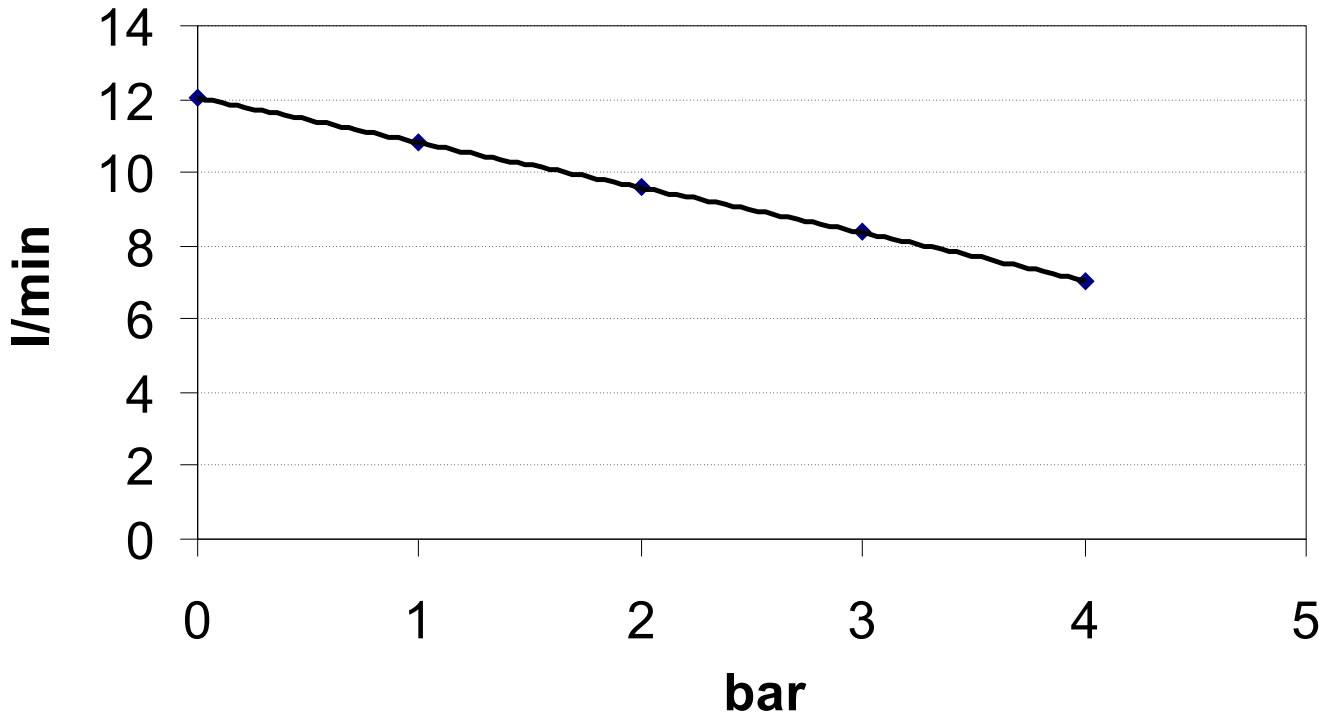
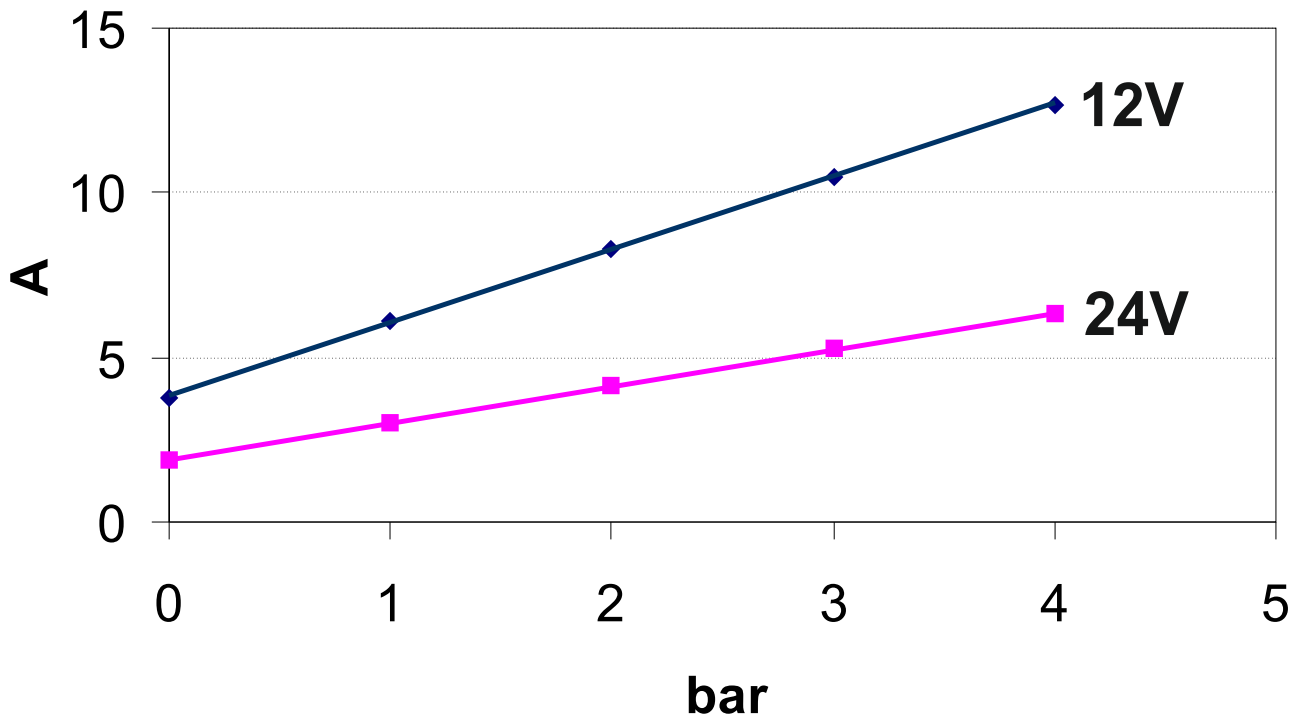
Self-priming electric pump for heavy duty with long running or max pressure 4 bar. The pumping elements are made up of PTFE gear drives which can possibly even run dry for brief periods. Completely equipped with in-line filter on the inlet side.

TECHNICAL DETAILS

B

CODICE	TIPO	VOLT	FUSIBILE	PORTATA	PRESSIONE	PESO	P.ZI x CART.
CODE	TYPE	VOLT	FUSE	FLOW RATE	PRESSURE	WEIGHT	PCS x CART.
164 103 12	UP9-XA	12	15 A	12 l/min	4 bar	2,7 kg	6
164 103 13		24	7,5 A				

AMBIENT CONDITIONS

C

Ambient operating conditions:

Temperature: min. -10 °C / max. +60 °C **Relative humidity:** max. 90 %

Warning: the above indicated temperature ranges are applicable to all components of the pump and these limits must be respected in order to avoid any possible damage or malfunctioning.

ELECTRICAL CONNECTIONS

D

The electric pump must be connected to a source of direct current (either battery or transformer) with an amp rating of over 15A and 7,5A at nominal voltage of 12V and 24V respectively. The pump must be protected by a suitable rated fuse.

OPERATING CYCLE

E

The pump has been designed for discontinuous use. Under conditions of high operating pressures (eg. with closed or blocked outlet, excessive length of the delivery circuit and/or excessive pressure due to accessories), the pump can be subjected to elevated stresses and overheating and therefore should not be used for prolonged periods under such conditions.

APPLICATIONS

F

There are numerous fields of applications for the pump, however only exclusively with the allowed liquids mentioned:

- transfer of fluids in the chemical field
- acid and alkaline solutions
- acid solutions for batteries

G FLUIDS ALLOWED / NOT ALLOWED

ALLOWED:

Fluids which are compatible with stainless steel, PTFE and fluoroelastomer seals

NOT ALLOWED:

PETROL (GASOLINE)
FLAMMABLE LIQUIDS with PM < 55°C
LIQUIDS WITH VISCOSITY > 20 cSt
FOODSTUFF LIQUIDS
CORROSIVE CHEMICAL PRODUCTS

SOLVENTS

RELATED DANGERS

FIRE EXPLOSION
FIRE EXPLOSION
MOTOR OVERHEATING
FOODSTUFF LIQUID CONTAMINATION
PUMP CORROSION -
INJURY TO PERSONNEL
FIRE EXPLOSION
DAMAGE TO SEALS

It is users responsibility to make certain that the fluids to be transferred are compatible with the materials used in the pump (stainless steel, PTFE, fluoroelastomer)

H TRANSPORTATION AND HANDLING

Due to limited weight and dimensions the pump does not require the use of any special handling or lifting equipment. When handling manually, normal personal protective gear should be worn (safety shoes with toe piece, etc.)

The pump is carefully packed prior to shipment. Upon receiving, the pump packaging should be inspected for damages and the pump stored in a dry area.

I INSTALLATION

It is recommended that the use of the pump be according to normative safety standards and also as per the precautions listed below.

I-1 PACKAGING ENVIRONMENTAL DISPOSAL

The packaging material is not in any way polluting or dangerous and does not require any special environmental disposal precautions. Disposal should be carried out according to local regulations in place.

I-2 PRELIMINARY CHECKS

Check that there has been no damage to the pump during transportation or storage. Both inlet and outlet ports should be carefully cleaned removing possible dust or residual packaging material. Verify that the available electrical power supply corresponds to the pump specification requirements.

I-3 POSITIONING OF THE PUMP

The pump can be mounted in any position. Fix the pump utilizing suitable screws corresponding to the antivibration mounts supplied with the pump.

WARNING: THE PUMP MOTOR IS NOT EXPLOSION PROOF. Do not install the pump where flammable vapours or gases may be present. Install the pump in an accessible place for inspection.

It is good practice to avoid any pump contact with water splashes possibly causing water seepage into the motor with high risk of internal oxidation and/or short circuit.

TUBING CONNECTIONS

I-4

- Prior to making any tube/hose connections, check that the inlet ports have no end caps;
- Do not position the pump at a excessive height with respect to the minimum level of the fluid to be transferred. Damage may occur if this height is exceeded as the pump may not draw fluid. Make sure that the outlet tube is empty and without chokes
- Avoid choking the inlet or outlet tubes so that efficiency is optimized.
- The use of an inlet filter is recommended especially with fluids containing impurities (ASTM mesh 35). In this case frequent cleaning and maintenance of the filter is advisable. The standard filter withstands a maximum positive pressure of 0.5 bar.
- Utilize tubes and connection pieces that are resistant to the fluid types handled and avoid any possible environmental dispersion.

PUMP INSTALLATION

I-5

The electrical installation of the pump must include a protection fuse which is suitably rated as indicated on the motor label and sized with reference to the chosen point of application.

WARRANTY EXPIRES IF NO FUSE IS UTILIZED

Always mount the anti vibration rubber fittings supplied with the pump kit. Their usage ensures a consistent reduction in noise and vibration levels.

Electrical cabling size should depend on the distance between pump and battery power supply.

Up to 4 m length: 4 mm²

The use of undersized cabling can cause overheating of the electrical wiring and subsequent fire hazard. There will also be a voltage drop at the motor terminals with a consequent reduction in efficiency.

The flow rate value indicated on the motor label is obtained with a 13 mm internal tube diameter. Tubes with inferior diameters will cause an increase in current with potential risk of motor overheating.

To ensure the correct directional flow of the fluid as indicated by the arrow on the top of the pump, it is necessary to connect the positive pole (+) of the battery supply to red wire on the motor end-cap and the negative pole (-) to the black wire. Electrical connections must be made using adequate terminal blocks and connectors ensuring a tight fitment of the electrical cables. Bad wiring can cause power losses and/or overheating of the cabling itself.

WARNING: it is the responsibility of the installation technician to ensure a correctly designed circuit installation fitted according to regulations. Environmental risks must be taken into account with the installation.

L

TROUBLESHOOTING

L-1

CHECK POINTS IF THE PUMP HAS STOPPED OR WILL NOT START

- Check the effectiveness of the battery power supply (voltage activity)
- Check if the fuse has blown
- Check for any foreign matter present in-between the pump gear drives. To do this, disconnect the power supply and unscrew the four fixing screws, remove the pump front cover plate and inspect the pump chamber. Replace the cover plate in the same initial position after inspection.
- Avoid running the pump dry for more than a few minutes. Pumps found defective that have run dry in the absence of fluid are not covered by warranty.
- The average life span of the motor commutator brushes is approximately 1500 hours under normal operating conditions. Stoppages are possible due to brush wear and tear after such a time period.

L-2

WHY THE PUMP WILL NOT PRIME ITSELF?

- The pump is fitted at a height greater than 1,5m above the fluid level.
- The pump has run dry for too long a period
- Long periods of inactivity. In this case it is advisable to add liquid directly into the pump chamber before start-up. It is also advisable to add, before running the pump, a drop of lubricating oil inside the pump only.
- Air leak at the suction pipe due to the following reasons:
 - Possible cuts in the pipe, inadequate hose clamps, malfunctioning of the filter due to defective/worn seals or filter clogged.
- Air leak at the pump front plate cover due to the following reasons:
 - Loose fixing screws, poor effectiveness of the seal.
- Faulty electrical cable connections
- Presence of obstructions or restrictions in the suction or delivery pipes or the use of special devices(eg. automatic spray pistol or aqua-stop).
- Presence of liquid loops in the outlet tube.

L-3

GOOD PRACTICES ENSURING A WELL FUNCTIONING PUMP

No particular maintenance is required if the pump is utilized for the transfer of diesel fluids. If it is expected that the pump will not be used for a period of at least 30 days, especially in the case of usage with fresh or salty water, it is advisable to run fresh water through the pump and to then loosen the pump front plate screws.

Upon re-use, run the pump briefly (a few seconds) and then tighten the screws again. Check under conditions of maximum operating pressure that the motor current value is within the motor label specifications.

NORMAL MAINTENANCE

L-4

- Check frequently and keep the inlet filter clean.
- Check every month the pump chamber and keep clean from any foreign matter.
- Check every month that electrical wiring is in good condition.
- Every 1500 hours of pump operation substitute the motor brushes.

INDICATORS THAT THE PUMP IS FUNCTIONING CORRECTLY

L-5

- Temperature of pump body and motor frame is within 60°C - 70°C
- Regular flow and constant pump noise levels
- Amp-draw within the limits indicated in the technical details.

TO OPEN THE PUMP

L-6

It is recommended that a specialized service technician be consulted for any pump repair work or the replacement of worn out internal components, exclusively with original spare parts.

During the warranty period, only by authorized Marco S.p.A. personnel, failing which the warranty will expire.

ENVIRONMENTAL DISPOSAL

M

Should the pump be discarded, do not pollute the environment. Please refer to the local environmental regulations.

WARRANTY

N

- 1) The Warranty period is 2 years from date of purchase on production of the appropriate sales invoice.
- 2) Should the original sales invoice not be available, then the 2 year warranty period will be valid from date of production.
- 3) The Warranty becomes null and void in the case of incorrect utilization or disregard of the instructions contained herein.
- 4) The Warranty only covers original production defects.
- 5) The Warranty does not cover any related installation costs involved.
- 6) Transport costs are refundable only in the case where warranty has been duly recognized and accepted by Marco Spa. These costs will be limited to the actual shipment costs between Marco Spa warehouse and the client's delivery address.
- 7) No credit notes or replacement items will be issued prior to the receipt and proper testing of any Marco goods that are deemed faulty.

O

EXPLODED VIEW

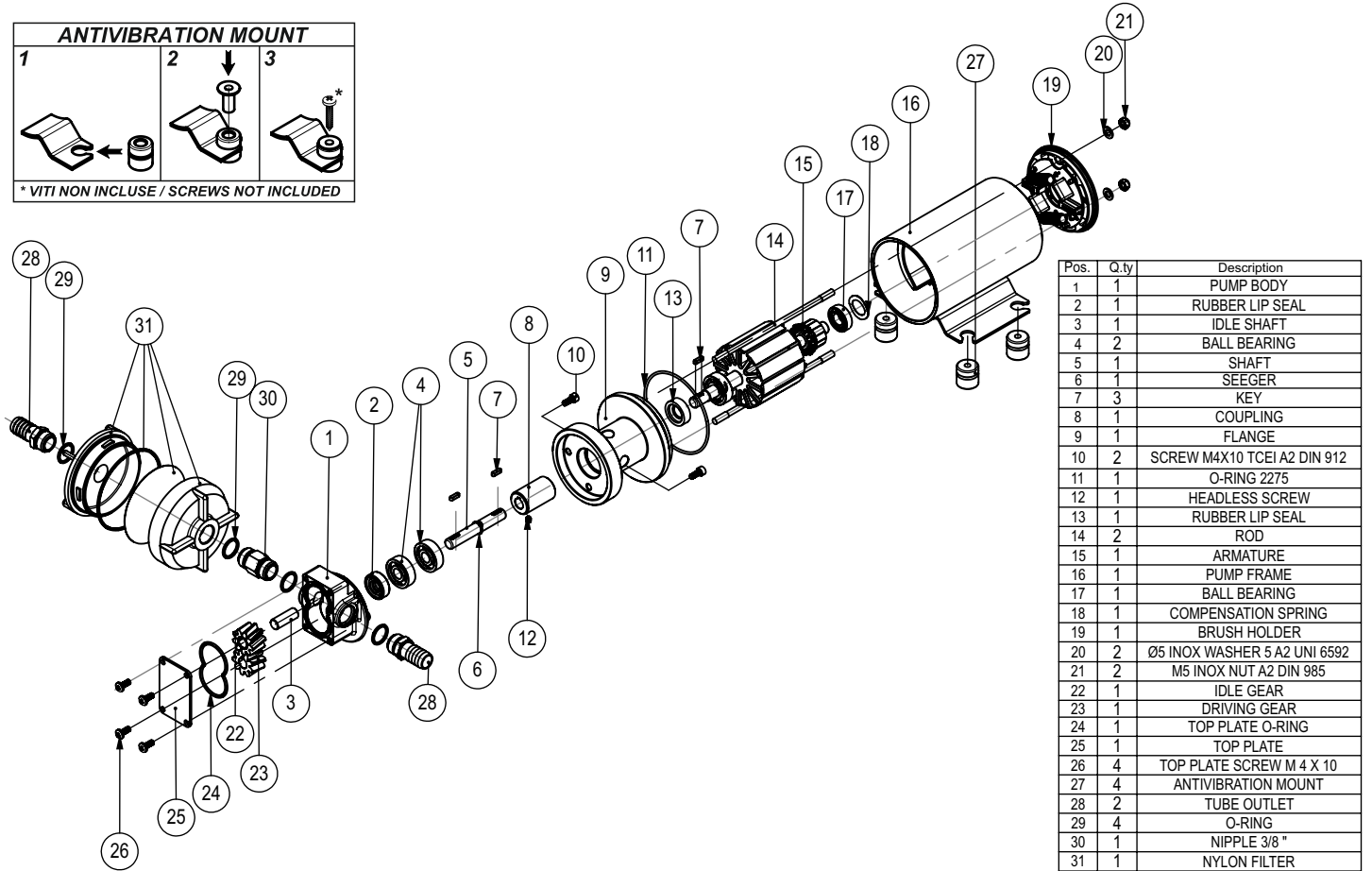
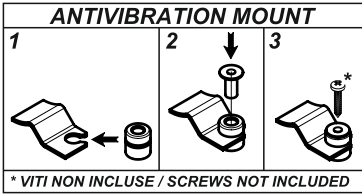

P

DIMENSIONS



DIAGRAMMA PORTATA FLOW RATES DIAGRAM



DIAGRAMMA ASSORBIMENTI AMPERE-DRAW DIAGRAM

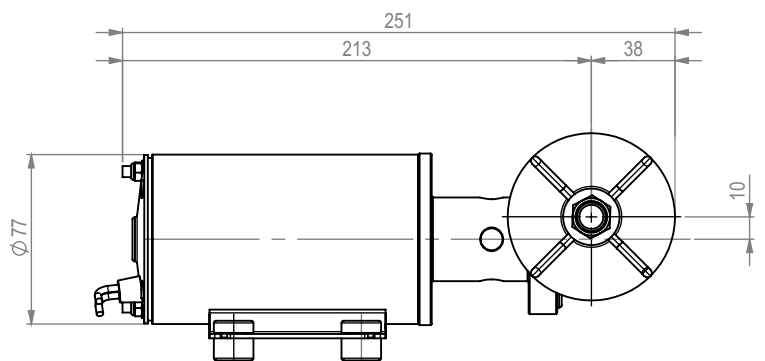
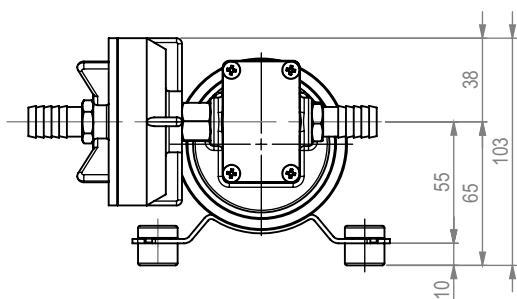
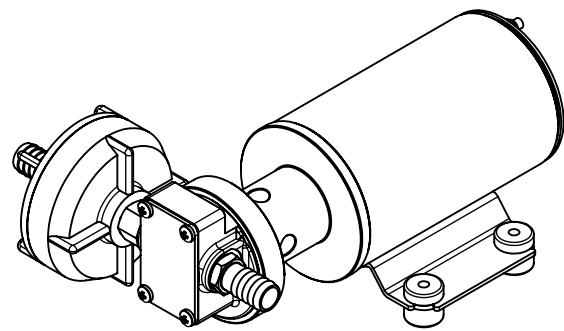
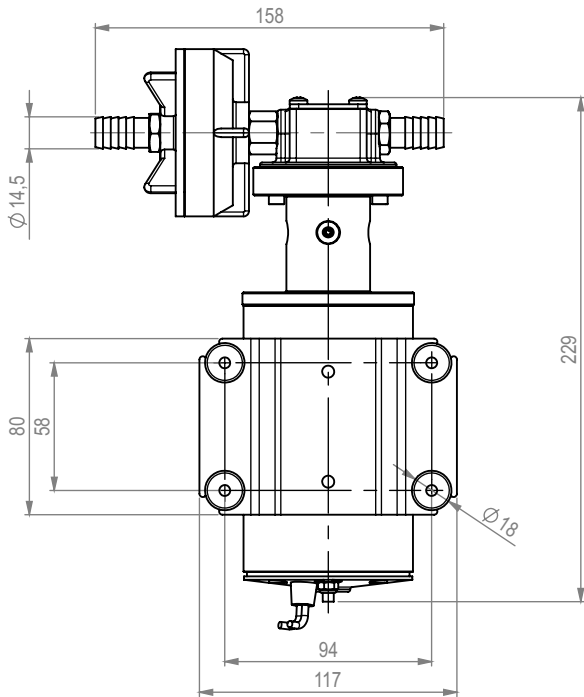

MARCO PUMPS & ACCESSORIES LIST

ITEM	DESCRIPTION
1620011C	UP1 220V a.c. rubber impeller pump 30 l
16200012	UP1 12V rubber impeller pump 35 l
16200013	UP1 24V rubber impeller pump 35 l
16200212	UP1-N 12V rubber impeller pump 35l
16200213	UP1-N 24V rubber impeller pump 35l
16420012	UP2 12V gear pump 8 l
16420013	UP2 24V gear pump 8 l
16466015	UP2/A 12/24V automatic pump with electronic pressure switch 8 l
16422012	UP2/OIL 12V gear pump for lubricating oil
16422013	UP2/OIL 24V gear pump for lubricating oil
16420212	UP2/P 12V PTFE gear pump 8 l
16420213	UP2/P 24V PTFE gear pump 8 l
16420412	UP2-PV 12V PTFE gear pump 8 l + non-return valve
16420413	UP2-PV 24V PTFE gear pump 8 l + non-return valve
1640031C	UP3/AC 220V 50Hz oil / diesel gear pump 10 l
1640011C	UP3/AC 220V a.c. gear pump 10 l
16400012	UP3 12V gear pump 14 l
16460012	UP3/A 12V automatic pump group with accumulator
16460215	UP3/E 12/24V automatic pump with electronic pressure switch 14 l
16402012	UP3/OIL 12V gear pump for oil
16400212	UP3/P 12V PTFE gear pump 14 l
16400013	UP4 24V gear pump 14 l
16460013	UP4/A 24V automatic pump group with accumulator
16402013	UP4/OIL 24V gear pump for oil
16400213	UP4/P 24V PTFE gear pump 14 l
1640621C	UP6/AC 220V a.c. gear pump 28 l
1640611C	UP6 220V a.c. gear pump 28 l
16406012	UP6 12V gear pump 26 l
16406013	UP6 24V gear pump 26 l
16462012	UP6/A 12V automatic pump group with accumulator
16462013	UP6/A 24V automatic pump group with accumulator
16462215	UP6/E 12/24V automatic pump with electronic pressure switch 26 l
16408012	UP6/OIL 12V gear pump for oil
16408013	UP6/OIL 24V gear pump for oil
16410012	UP9 12V heavy duty gear pump
16410013	UP9 24V heavy duty gear pump
16464012	UP9/A 12V heavy duty automatic pump group with accumulator
16464013	UP9/A 24V heavy duty automatic pump group with accumulator
16410212	UP9-PN 12V internal brushes PTFE gear pump
16410213	UP9-PN 24V internal brushes PTFE gear pump
16440012	UP10 12V bronze gear pump 18 l
16440013	UP10 24V bronze gear pump 18 l
16440212	UP10/P 12V PTFE gear pump 18 l
16440213	UP10/P 24V PTFE gear pump 18 l

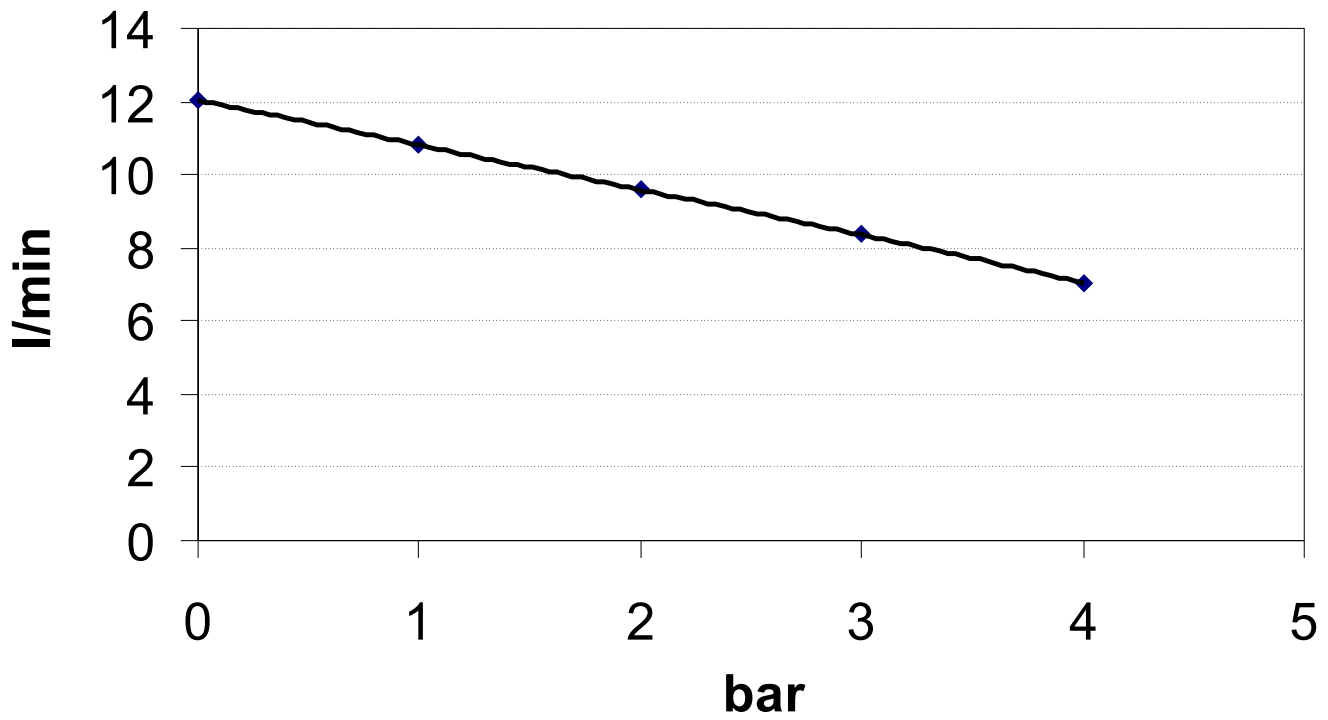
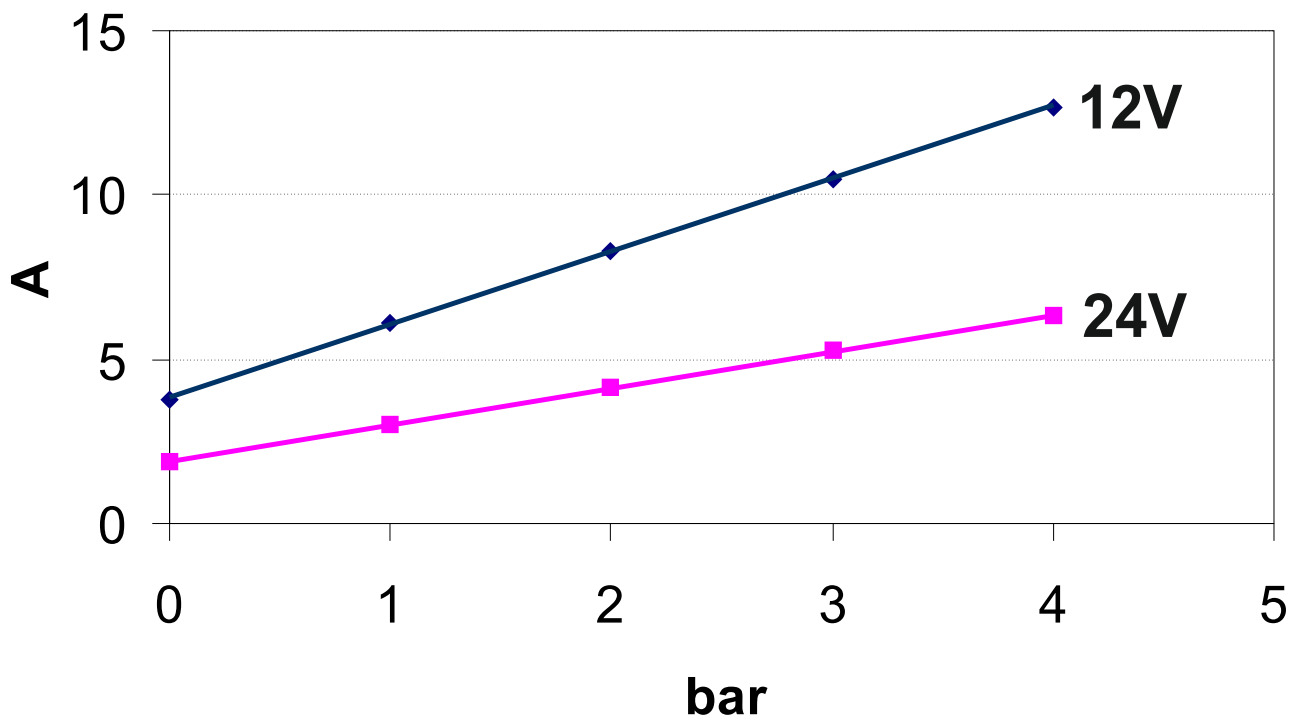
ITEM	DESCRIPTION
16430013	UP12 24V gear pump 40 l
16468012	UP12/A 12V water pressure pump system
16468013	UP12/A 24V water pressure pump system
16468215	UP12/E 12/24V automatic pump with electronic pressure switch 40 l
16432012	UP12/OIL 12V bronze gear pump 15 l
16432013	UP12/OIL 24V bronze gear pump 15 l
16430212	UP12/P 12V PTFE gear pump 40 l
16430213	UP12/P 24V PTFE gear pump 40 l
1640421C	UPX 220V a.c. gear pump 10 l stainless-steel version
16404012	UPX 12V gear pump 14 l stainless-steel AISI 316
16404013	UPX 24V gear pump 14 l stainless-steel AISI 316
1640431C	UPX-C 220V a.c. stainless-steel gear pump for chemicals 10 l
16404112	UPX-C 12V stainless-steel gear pump for chemicals 14 l
16404113	UPX-C 24V stainless-steel gear pump for chemicals 14 l
16410112	UP9-XC 12V heavy duty gear pump - s.s. AISI 316
16410113	UP9-XC 24V heavy duty gear pump - s.s. AISI 316
16410312	UP9-XA 12V herbicides pump version
16410313	UP9-XA 24V herbicides pump version
16440112	UP10-XC 12V heavy duty gear pump - s.s. AISI 316 - 18 l
16440113	UP10-XC 24V heavy duty gear pump - s.s. AISI 316 - 18 l
16490015	SP2 12/24V shower pump
16480012	DP3 12V deck washing pump
16480013	DP3 24V deck washing pump
16482012	DP9 12V deck washing pump
16482013	DP9 24V deck washing pump
16484012	DP12 12V deck washing pump
16484013	DP12 24V deck washing pump
16010012	UP500 12V bilge pump
16010013	UP500 24V bilge pump
16012012	UP1000 12V bilge pump
16012013	UP1000 24V bilge pump
16014012	UP1500 12V bilge pump
16014013	UP1500 24V bilge pump
16016012	UP2000 12V bilge pump
16016013	UP2000 24V bilge pump
16018013	UP3700 24V bilge pump



Associazione AIB
associazione
industriale
bresciana

DICHIARAZIONE DI CONFORMITA' C.E. E.C. DECLARATION OF CONFORMITY

Confermiamo che il prodotto:
We confirm that the product:

164 103 12 - UP9-XA 12V Pompa a ingranaggi 12 l / gear pump

164 103 13 - UP9-XA 24V Pompa a ingranaggi 12 l / gear pump

E' conforme alla Direttiva 2004/108/CE (ex.89/336/CE) relativa alla compatibilità elettromagnetica.
is in conformity with the Directive 2004/108/EC (ex.89/336/EC) relating to electromagnetic compatibility.

Questa dichiarazione è valida per tutti gli articoli prodotti secondo la documentazione tecnica che è parte di questa dichiarazione. In caso di eventuali verifiche pertinenti alla Compatibilità Elettromagnetica sono state applicate le seguenti normative:

This declaration is valid for all products which are produced in accordance with the technical documentation which is a part of this declaration. For verification of conformity with regard to Electromagnetic Compatibility the following standards are applied:

EN 55014-1

Compatibilità elettromagnetica.
Requisiti per gli elettrodomestici,
gli utensili elettrici e apparecchi simili.
Parte 1: Emissione.

*Electromagnetic compatibility.
Requirements for household appliances,
electric tools, and similar apparatus.
Part 1: Emission.*

Questa dichiarazione è rilasciata sotto la responsabilità esclusiva di:

This declaration is given under the sole responsibility of:

MARCO S.P.A.
Via Mameli 10 - 25014 Castenedolo - Brescia - Italy
Tel. 030/2134.1 Fax 030/2134.300

Per ulteriori informazioni vedere sito internet - www.marco.it
Marco S.p.A Via Mameli 10 - 25014 Castenedolo - Brescia - Italy
tel. +39 030 2134.1 / Fax +39 030 2134.300

For further information visit the web site - www.marco.it
Marco S.p.A Via Mameli 10 - 25014 Castenedolo - Brescia - Italy
tel. +39 030 2134.1 / Fax +39 030 2134.300