

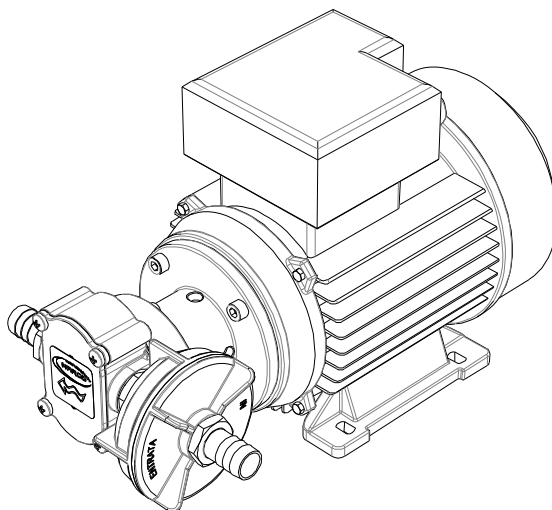

**SELF-PRIMING ELECTRIC PUMP
FOR TRANSFERRING VARIOUS LIQUIDS**

INSTRUCTIONS FOR USE

164 061 1B - UP6/AC 110 V



CE

03/05/13 Rev.00

PRODUCT DESCRIPTION

Self-priming electric pump for the transfer of liquids of varied nature for discontinuous or intermittent usage. The pumping elements are made up of PTFE gears which can possibly even run dry for brief periods. Completely equipped with in-line filter on the inlet side.

TECHNICAL DETAILS



Tab.1 EN												
CODE	TYPE	VOLT	FUSE		FLOW RATE *		PRESSURE		WEIGHT		WIRE SIZE **	
164 061 1B	UP6/AC	110	A	5	l/min	34	bar	4	kg	10,6	mmq	2
					gpm	9,0	psi	58	lb	23,4	AWG	14
* Internal tube Ø 0,63" / ** Length up to 100 ft												
IP 55 Protection												

APPLICATIONS

There are numerous fields of applications for the pump, however only exclusively with the allowed liquids mentioned:

- transfer of diesel fuel between tanks, refuelling of tractors and earth moving equipment
- transfer of water
- transfer of light weight lube oils, antifreeze, etc.

FLUIDS ALLOWED / NOT ALLOWED

Tab.2 EN		LIQUIDS						DANGERS 					
WARRANTY EXPIRES IF MAX FLUID TEMPERATURE IS EXCEEDED								FIRE / EXPLOSION	MOTOR OVERHEATING	FOODSTUFF LIQUID CONTAMINATION	PUMP CORROSION	INJURY TO PERSONNEL	DAMAGE TO SEALS
NO 	PETROL (GASOLINE)							●					
	FLAMMABLE LIQUIDS with PM < 55°C-131°F							●					
	LIQUIDS WITH VISCOSITY > 20 cSt								●				
	FOODSTUFF LIQUIDS									●			
	CORROSIVE CHEMICAL PRODUCTS										●	●	
	SOLVENTS							●					●

* With viscosity between 2 and 5.35 cSt (to 37,8°C - 100°F temperature), Minimum flashpoint (PM): 55°C-131°F.

AMBIENT CONDITIONS

TEMPERATURE: min.-10°C 14°F-max.60°C 140°F **RELATIVE HUMIDITY:** max. 90 %

 **WARNING:** the above indicated temperature ranges are applicable to all components of the pump and these limits must be respected in order to avoid any possible damage or malfunctioning.

OPERATING CYCLE

The pump has been designed for discontinuous use. Under conditions of high operating pressures (eg. with closed or blocked outlet, excessive length of the delivery circuit and/or excessive pressure due to accessories), it can be subjected to elevated stresses and overheating and therefore should not be used for prolonged periods under such conditions.

TRANSPORTATION AND HANDLING

Due to limited weight and dimensions the pump does not require the use of any special handling or lifting equipment. When handling manually, normal personal protective gear should be worn (safety shoes with toe piece, etc.). The pump is carefully packed prior to shipment. Upon receiving, the packaging should be inspected for damages and the pump stored in a dry area.

INSTALLATION

It is recommended that the use of the pump be according to normative safety standards and also as per the precautions listed below.

PRELIMINARY CHECKS

Check that there has been no damage to the pump during transportation or storage. Both inlet and outlet ports should be carefully cleaned removing possible dust or residual packaging material. Verify that the available electrical power supply corresponds to the specification requirements.

POSITIONING

The pump can be mounted in any position. Fix the pump utilizing suitable diameter screws corresponding to the holes of the flange.

 **WARNING: THE PUMP MOTOR IS NOT EXPLOSION PROOF.**

Do not install the pump where flammable vapours or gases may be present. Install the pump in an accessible place for inspection. The pump is IP55 protection rated. It is good practice to avoid any pump contact with water splashes possibly causing water seepage into the motor with high risk of internal oxidation and/or short circuit. It is the responsibility of the installation technician to ensure a correctly designed circuit installation fitted according to regulations. Environmental risks must be taken into account with the installation.

TUBING CONNECTIONS

- Prior to making any tube/hose connections, check that the inlet ports have no end caps;
- Do not position the pump at a excessive height with respect to the minimum level of the fluid to be transferred. Damage may occur if this height is exceeded as the pump may not draw fluid. Make sure that the outlet tube is empty and without chokes;
- Avoid choking the inlet or outlet tubes so that efficiency is optimized.
The use of an inlet filter is recommended especially with fluids containing impurities (ASTM mesh 35). In this case frequent cleaning and maintenance of the filter is advisable. Utilize tubes and connection pieces that are resistant to the fluid types handled and avoid any possible environmental dispersion.

ELECTRICAL CONNECTION

The electrical installation of the pump must include a protection fuse which is suitably rated as indicated on the motor label.

WARRANTY EXPIRES IF NO FUSE IS UTILIZED

Electrical cabling size should depend on the distance between pump and battery power supply (see Tab.1 EN). The use of undersized cabling can cause overheating of the electrical wiring and subsequent fire hazard. There will also be a voltage drop at the motor terminals with a consequent reduction in efficiency. The flow rate value indicated on the motor label is obtained with internal tube diameter indicated on Tab.1 EN. Tubes with inferior diameters will cause an increase in current with potential risk of motor overheating.

TROUBLESHOOTING

CHECK POINTS IF THE PUMP HAS STOPPED OR WILL NOT START

- Check the effectiveness of the battery power supply (voltage activity);
- Check if the fuse has blown;
- Check for any foreign matter present in the pump body. To do this, disconnect the power supply and unscrew the four fixing screws, remove the front cover plate and inspect the chamber. Replace the cover plate in the same initial position after inspection;
- Avoid running the pump dry for more than a few minutes. Pumps found defective that have run dry in the absence of fluid are not covered by warranty.

WHY THE PUMP WILL NOT PRIME ITSELF?

- The pump is fitted at an excessive height above the fluid level;
- The pump has run dry for too long a period;
- Long periods of inactivity. In this case it is advisable to add liquid directly into the chamber before start-up. It is also advisable to add, before running the pump, a drop of lubricating oil inside the pump only;
- Air leak at the suction pipe due to the following reasons, possible cuts in the pipe, inadequate hose clamps, malfunctioning of the filter due to defective/worn seals or filter clogged;
- Air leak at the front plate cover due to the following reasons, loose fixing screws, poor effectiveness of the seal;
- Faulty electrical cable connections;
- Presence of obstructions or restrictions in the suction or delivery pipes or the use of special devices(eg. automatic spray pistol or aqua-stop);
- Presence of liquid loops in the outlet tube.

GOOD PRACTICES ENSURING A WELL FUNCTIONING PUMP

If it is expected that the pump will not be used for a period of at least 30 days, especially in the case of usage with water, it is advisable to run fresh water through it and to then loosen the front plate screws. Upon re-use, run the pump briefly (a few seconds) and tighten the screws again. Check under conditions of maximum operating pressure that the motor current value is within the motor label specifications.

NORMAL MAINTENANCE

- Check frequently and keep the inlet filter clean;
- Check every month the chamber and keep clean from any foreign matter;
- Check every month that electrical wiring is in good condition.

INDICATORS THAT THE PUMP IS FUNCTIONING CORRECTLY

- Regular flow and constant noise levels;
- Amp-draw within the limits indicated in the technical details.

TO OPEN THE PUMP

- It is recommended that a specialized service technician be consulted for any repair work or the replacement of worn out internal components, exclusively with original spare parts;
- During the warranty period, only by authorized Marco S.p.A. personnel, failing which the warranty will expire.

ENVIRONMENTAL DISPOSAL

Do not dispose of pumps into household waste: pumps that are no longer usable, must be collected separately and disposed of in an environmentally correct manner.

PACKAGING ENVIRONMENTAL DISPOSAL

The user is invited to effect a proper waste separation, in order to facilitate the recycling of the materials of which the packing is composed.

WARRANTY

- 1) The Warranty period is 2 years from date of purchase on production of the appropriate sales invoice.
- 2) Should the original sales invoice not be available, then the 2 year warranty period will be valid from production date.
- 3) The Warranty becomes null and void in the case of incorrect utilization or disregard of the instructions contained herein.
- 4) The Warranty only covers original production defects.
- 5) The Warranty does not cover any related installation costs involved.
- 6) Transport costs are refundable only in the case where warranty has been duly accepted by Marco Spa and they will be limited to the actual shipment costs between Marco Spa warehouse and the client's delivery address.
- 7) No credit notes or replacement items will be issued prior to the receipt and proper testing of any Marco goods that are deemed faulty.

EXPLODED VIEW

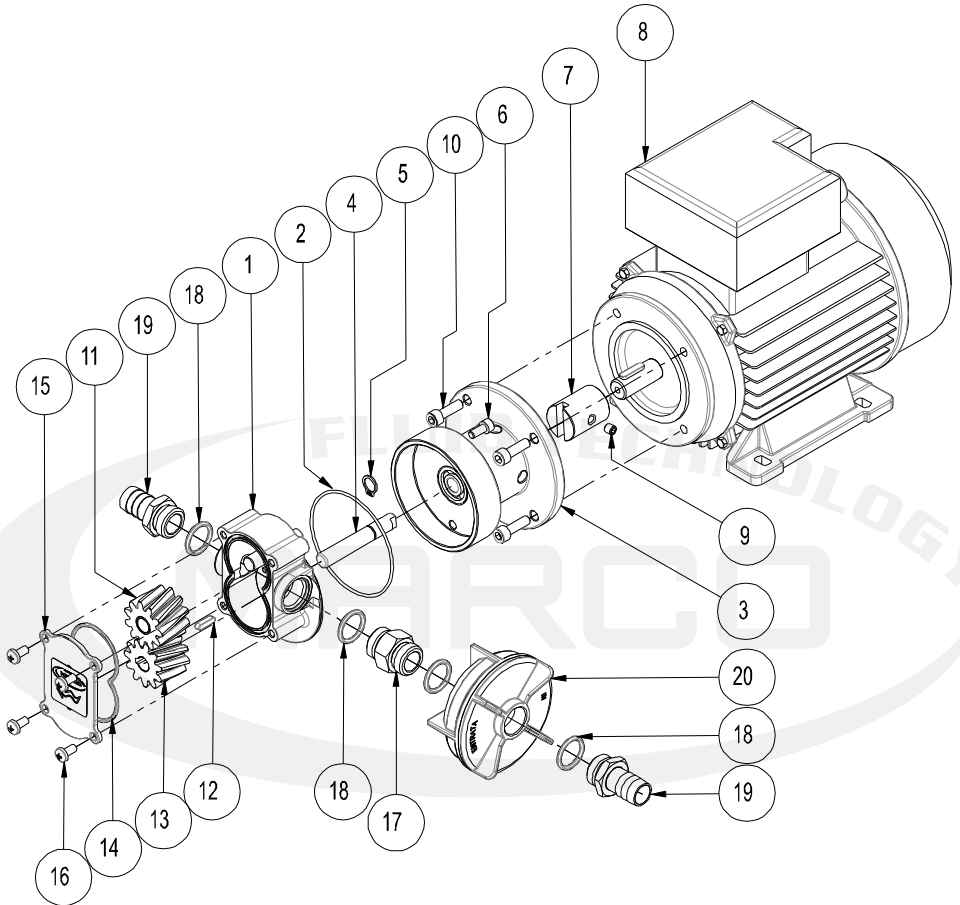

Pos.	Q.ty	Description
1	1	PUMP BODY
2	1	O-RING
3	1	FLANGE
4	1	SHAFT
5	1	SEEGER
6	2	SCREW
7	1	COUPLING
8	1	MOTOR
9	1	HEADLESS SCREW
10	4	SCREW

Pos.	Q.ty	Description
11	1	IDLE GEAR
12	1	KEY
13	1	DRIVING GEAR
14	1	O-RING
15	1	TOP PLATE
16	4	SCREW
17	1	NIPPLE
18	4	O-RING
19	2	TUBE OUTLET
20	4	FILTER

DIMENSIONS

mm [pollici / inches]

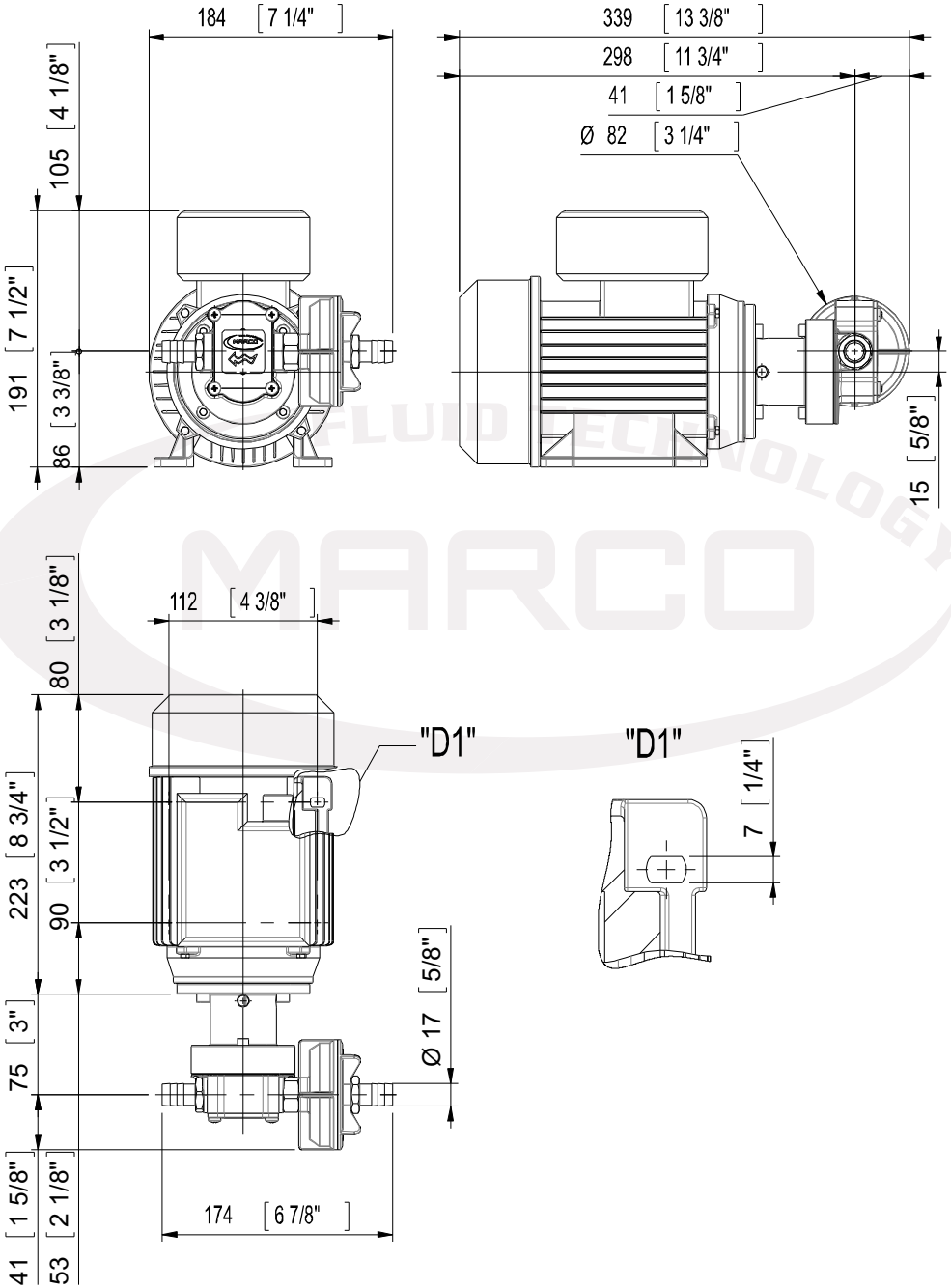



Associazione
Industriale
Bresciana

E.C. DECLARATION OF CONFORMITY

We confirm that the product:

164 061 1B - UP6/AC 110V Gear pump

*Is in conformity with 73/23/EC Directive relating to Low Voltage and
with 2004/108/EC Directive relating to the Electromagnetic Compatibility*

*This declaration is valid for all products which are produced in accordance with the technical documentation which is
a part of this declaration. For verification of conformity with regard to the security of electric machines and to the
Electromagnetic Compatibility the following standards are applied:*

EB60335-2-41:1990
+A51:1991

*Security of electric machines for the domestic use and similar uses.
Particular applications of electric pumps with liquids that do not exceed 35°C.*

EN50081 - 1 / 03.93

Generic emission standard, residential, commercial and light industry.

EN50082 - 2 / 03.95

Generic waves immunity standard, industrial environment

EC product marking from: September'96.

This declaration is given under the sole responsibility of:

MARCO S.P.A.
Via Mameli 10 - 25014 Castenedolo - Brescia - Italy
Tel. 030/2134.1 Fax 030/2134.300

NOTES

Handwriting practice lines consisting of a solid top line, a dashed middle line, and a solid bottom line. The page contains 20 such lines.



Per ulteriori informazioni vedere nostro sito internet - www.marco.it
Marco S.p.A Via Mameli 10 - 25014 Castenedolo (Brescia) - Italia
tel. +39 030 2134.1 / Fax +39 030 2134.300

For further information visit our web site - www.marco.it
Marco S.p.A Via Mameli 10 - 25014 Castenedolo (Brescia) - Italy
tel. +39 030 2134.1 / Fax +39 030 2134.300