PE-2F-PW SERIES



Features

- Environmentally safe, oil-less
- Energy efficient
- Corrosion resistant body
- 15' Cord
- 12.2' maximum lift
- 47 watts
- 1/4" MNPT Discharge
- For submersible use only

Construction

- Motor — 1/40 HP Epoxy Encapsulated
- Intermittent Liquid Temp. up to — 120° F
- Intake — Screened
- Discharge — 1/4" MNPT
- Housing — Glass-filled polyester
- Cover — Glass-filled polyester
- Volute — Nylon
- Impeller — Nylon
- Shaft Seal — Viton[®]
- Screen — Polypropylene

This pump features an epoxy-encapsulated motor, plastic housing and radial lip seal on the motor shaft. It provides enough power to effectively operate a water garden, statuary, or tabletop fountain. Algae build-up does not effect this small, powerful workhorse. In fact, it may even be used in some harsh, industrial-type applications. This "potted" pump is usually more compact in size than an oil-filled pump of equal flow capacity.

Little Giant Pump Co.

PE-2F-PW SERIES

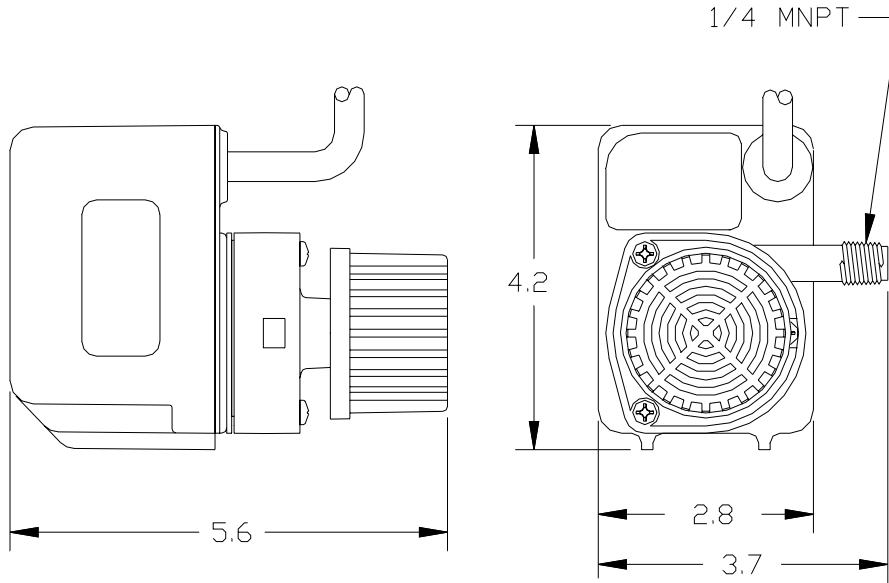

Specifications

Model No.	Item No.	Discharge	Listings	HP	Volts	Hertz	Amps	Watts	Performance (GPH @ Head)					Shut Off		Pwr. Cord (ft)	Weight (Lbs.)
									1'	3'	5'	8'	10'	Feet	PSI		
PE-2F-PW	566632	1/4" MNPT	UL/CSA	1/40	115	60	0.8	47	300	270	240	180	130	12.2	5.3	15	4.83

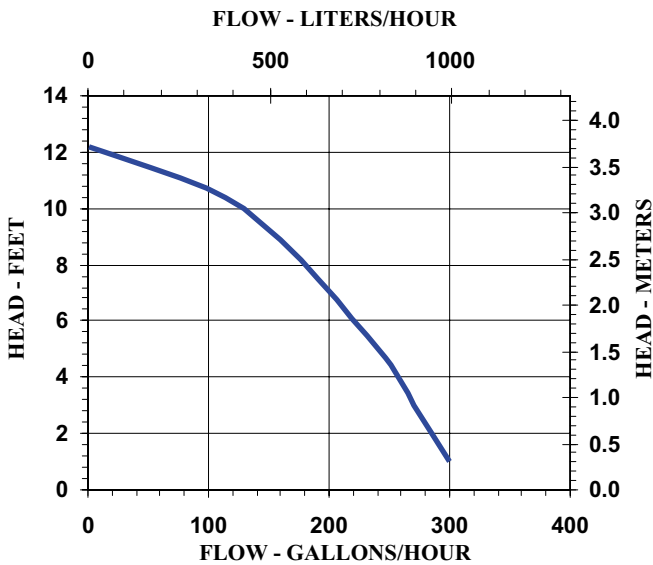

Replacement Parts

Volute	102375
Impeller	102703
Screen	118911
Gasket	102601

Little Giant Pump Co.
 PO Box 12010
 Okla. City, OK 73157
 Phone: 405.947.2511
 Fax: 405.228.1550
www.LittleGiantPump.com