

HI-TEMPERATURE 10E SERIES

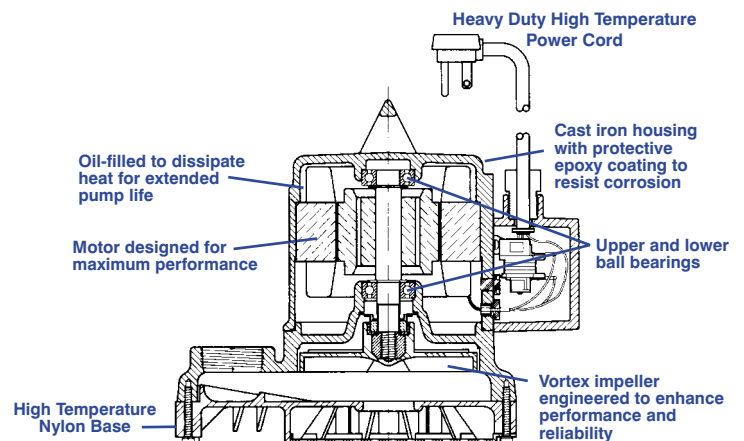

Features

- Handles liquids up to 200°F
- Handles liquids and solid waste materials up to 3/4" diameter
- Cast iron pump housing with protective epoxy coating for corrosion and rust resistance
- Oil-filled motor housing for lifetime lubrication and rapid heat dissipation
- Stainless steel fasteners
- Mechanical seals (stainless steel spring, Viton parts, carbon and ni-resist faces)
- Thermal overload protection
- Manual and Automatic models
- Automatic operation has 10 to 12 "On" level and 2 to 4 "Off" level range with integral mercury float switch
- All 115 volt models are CSA listed.



This high temperature version of the 10E Sump/Effluent Pump is capable of pumping up to 200°F liquid. Uses include boiler blow-down pits, rendering plant wash-down sump pits, public utility underground transformer vaults, industrial steam cleaning sump pits, etc. Pumps feature a 1-1/2" discharge, with a lift of 24'. Cast iron housing, volute, and relay housing with protective epoxy coating, nylon base and vortex nylon impeller.

Little Giant Pump Co.

HI-TEMPERATURE 10E SERIES

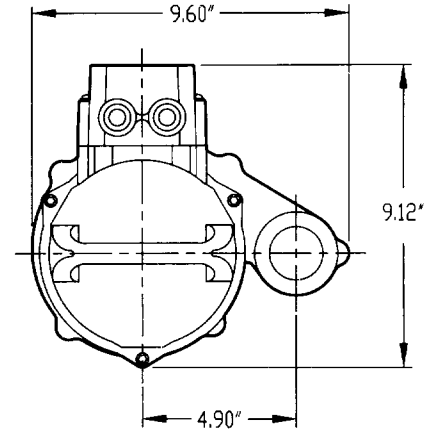
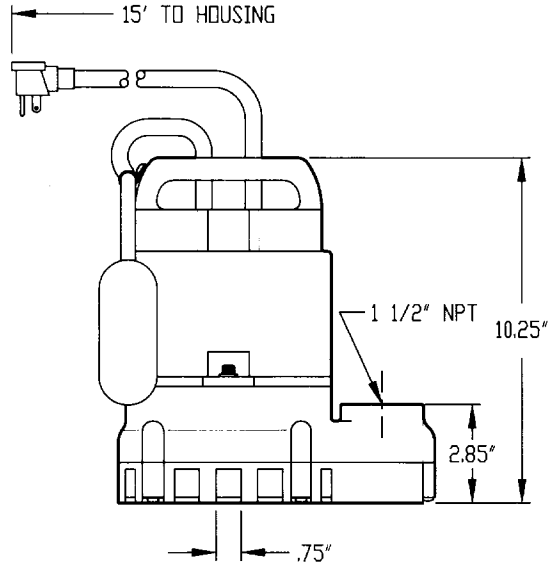

Specifications

MODEL NO.	ITEM NO.	LISTINGS	HP	VOLTS/ Hz	SOLIDS SIZE (Dia. In.)	RUNNING AMPS/WATTS	WATER TEMPS	PERFORMANCE (GPM @ HEAD)				SHUTOFF		PWR. CRD. (Ft.)	WEIGHT (Lbs.)	DIMENSIONS (H x L x W in.)
								5'	10'	15'	20'	(Ft.)	P.S.I.			
HT-10E-CIM	511600	CSA	1/2	115	3/4	10.5/900	73° F	80	70	59	37	24	10.4	15	37	10.25 x 9.6 x 9.12
							200° F	75	67	52	22	22	9.5			
HT-10E-CIA-FS	511700	CSA	1/2	115	3/4	10.5/900	73° F	80	70	59	37	24	10.4	15	37	10.25 x 9.6 x 9.12
							200° F	75	67	52	22	22	9.5			

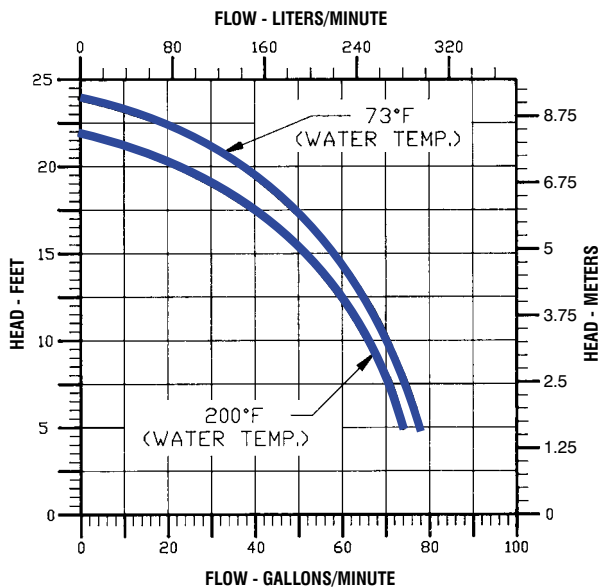

Construction

Motor housing	Epoxy-coated cast iron
Impeller material	Nylon
Impeller type	Vortex
Volute	Epoxy-coated cast iron
Power cord	15' 16-3 SJOW-A, Super Ultron II
Mechanical shaft seal	Viton, Stainless Steel, Carbon & Ni-Resist Faces
Fasteners	Stainless steel
Shaft	Stainless steel
Bearings	Upper and lower ball bearings



ISO 9001 CERTIFIED

Little Giant Pump Co.

PO Box 12010
Okla. City, OK 73157

Phone: 405.947.2511
Fax: 405.228.1550

www.LittleGiantPump.com

Form No. 994347 - 05/01