

JABSCO® BRONZE BALL BEARING SELF-PRIMING PUMP

PORT ¼" Dual Hose Connection Outlets,
1¼" Single Hose Connection Inlet

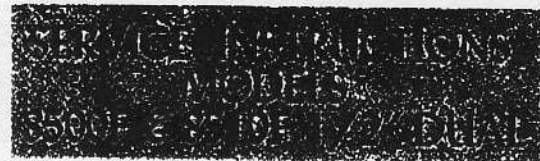

CROSS SECTION

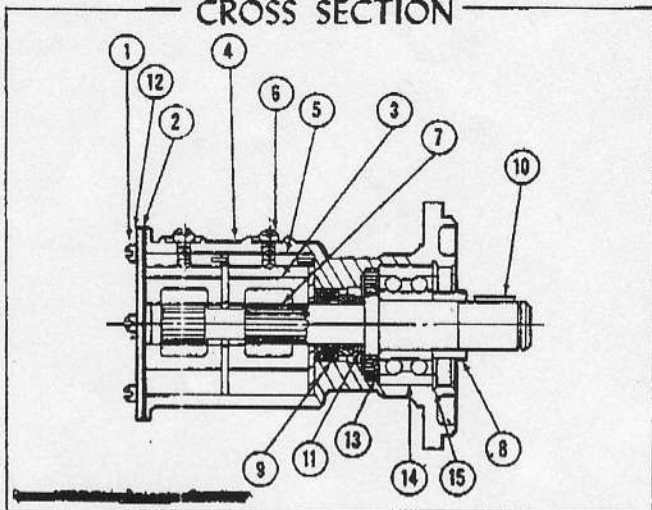

PARTS LIST

KEY	PART NUMBER	DESCRIPTION	QTY. REQ.
1	SP 1002-02	Screw (End Cover)	6
2	3298	Gasket	1
3	1212-08	Impeller Assembly	2
4	7124F	Body (Model 8500F)	1
	7324F	Body (Model 8510F)	
5	7607	Cam & Wearplate Assembly	2
6	SP 1003-01	Screw (Cam)	2
7	7127	Shaft	1
8	7126	Spacer	1
9	SP 6080-08	Seal Assembly	1
10	SP 1401-10	Key	1
11	9277	Seal Seat Spacer	1
12	8505F	End Cover (Model 8500F)	1
	8512F	End Cover (Model 8510F)	
13	913	Bearing Seal (Inner)	1
14	SP 2600-06	Ball Bearing	1
15	SP 1701-185	Retaining Ring	1

DISASSEMBLY

1. Remove end cover screws, end cover and gasket.
2. Remove front impeller by grasping across hub of impeller with water pump pliers.
3. Loosen front cam screw, tap screw to loosen cam, remove screw and cam (clean off Permatex).
4. Remove center wearplate.
5. Remove inner impeller by grasping opposite blades with regular pliers.
6. Loosen back cam screw, tap screw to loosen cam, remove screw and cam (clean off Permatex).
7. Remove bottom wearplate.

NOTE: For seal replacement only, at this point of disassembly.

- A. Insert a screwdriver in each opening of drain area between shoulder of shaft and seal seat spacer, using lever action against the seal seat spacer, force seal forward into impeller bore.
- B. If seal is not forced entirely out of seal bore, remove by grasping outside of protruding seal with pliers.
- C. Remove seal seat, seal seat gasket and seal seat spacer with hooked wire.

D. Reassemble following steps 7 through 16 of Assembly Instructions.

9. Remove bearing to body retaining ring.
10. Pressing on impeller drive end of shaft, remove shaft and bearing assembly from body.
11. Remove seal seat, seal seat gasket and seal seat spacer from shaft.
12. Remove key and spacer from drive end of shaft.
13. Supporting bearing inner race, press shaft through bearing.
14. Using extreme care not to mar body bore, insert screwdriver between O.D. of inner bearing seal and pump bore and pry out the seal.
15. Remove seal from bore by pressing from bearing bore end toward the body impeller bore.

ASSEMBLY

1. Lubricate inner bearing seal with water pump grease or equivalent and press into body bearing seal bore with lip facing the bearing.
2. Press shaft into bearing. Use care to support inner race of bearing.
3. Insert splined end of shaft into bearing bore and pressing on bearing outer race, press bearing and shaft assembly into bore.
4. Install bearing to body retaining ring in body groove with flat side toward bearing.
5. Install spacer over shaft and down against bearing.
6. Install key in shaft.
7. Slide seal seat spacer over shaft and down against shaft shoulder.
8. Slide seal seat and gasket assembly with rubber facing inward over shaft and down against seal seat spacer. Lubricate with water (do not use oil) to ease assembly. CAUTION: Use care not to scratch or mar seal seat face.
9. With carbon facing in toward seal seat, press seal into bore. CAUTION: Press on outermost edge of seal to prevent damage and press flush with bottom of body impeller bore.
10. Install bottom wearplate in bottom of impeller bore.
11. Permatex top side of cam and cam screw threads. Line up pins in cam with holes in wearplate. Install cam and secure with cam screw. NOTE: Hold cam in place during final tightening of cam screw to insure proper seating of the wearplate.
12. Lubricate impeller bore lightly with water pump grease in the bottom area and with a rotary motion, install the bottom impeller until it is seated against the wearplate.
13. Install second wearplate down against the bottom impeller.
14. Permatex top side of cam and cam screw threads. Line up pins in cam with holes in wearplate and install cam and secure with cam screw. NOTE: Before final tightening of the cam screw, tap cam lightly toward the bottom of the bore and hold in place while securing cam screw.
15. Lubricate remainder of the impeller bore and install second impeller with a rotary motion until splines engage. Then push into bore until it seats against the wearplate.
16. Install gasket and end cover and secure with end cover screws.

813 442 7867



8500F

JABSCO

SELF-PRIMING PUMP

OPERATING INSTRUCTIONS

1. **INSTALLATION**—Model 8500F will operate in clockwise rotation. For opposite rotation, use Model 8510F.
2. **SELF-PRIMING**—Primes at low or high speeds. Be sure suction lines are air-tight or pump will not self prime.
3. **RUNNING DRY**—Unit depends on liquid pumped for lubrication. **DO NOT RUN DRY** for more than 30 seconds. Lack of liquid will burn the impeller.
4. **TEMPERATURES**—Standard impeller is designed to handle liquid temperatures between 45° - 180°F.
5. **FREEZING WEATHER**—Drain unit by loosening the end cover. The following anti-freeze compounds can be used without any adverse effects to the impeller: Atlas "Permaguard", DuPont "Zerex" and "Telar", Dow Chemical "Dowguard" and Olin Mathison "Pyro". Most methyl alcohol (methanol) based anti-freeze can be used. **DO NOT USE PETROLEUM BASED ANTI-FREEZE COMPOUNDS OR RUST INHIBITORS.** NOTE: Our laboratory tests indicate no adverse effects to the Jabsco neoprene compound using "DuPont No. 7" or "Lazy-Way" rust inhibitors.
6. **GASKET**—Use standard pump part. Thicker gasket will reduce priming ability. A thinner gasket will cause impeller to bind.
7. **SPARE PARTS**—A JABSCO Service Kit SK-111 should be kept on hand to service all but the most badly worn pumps.

Insist on genuine Jabsco parts — made only by the Jabsco Pump Company — the original and world's leading manufacturer of self-priming flexible neoprene impeller pumps.

DIMENSIONAL DRAWING

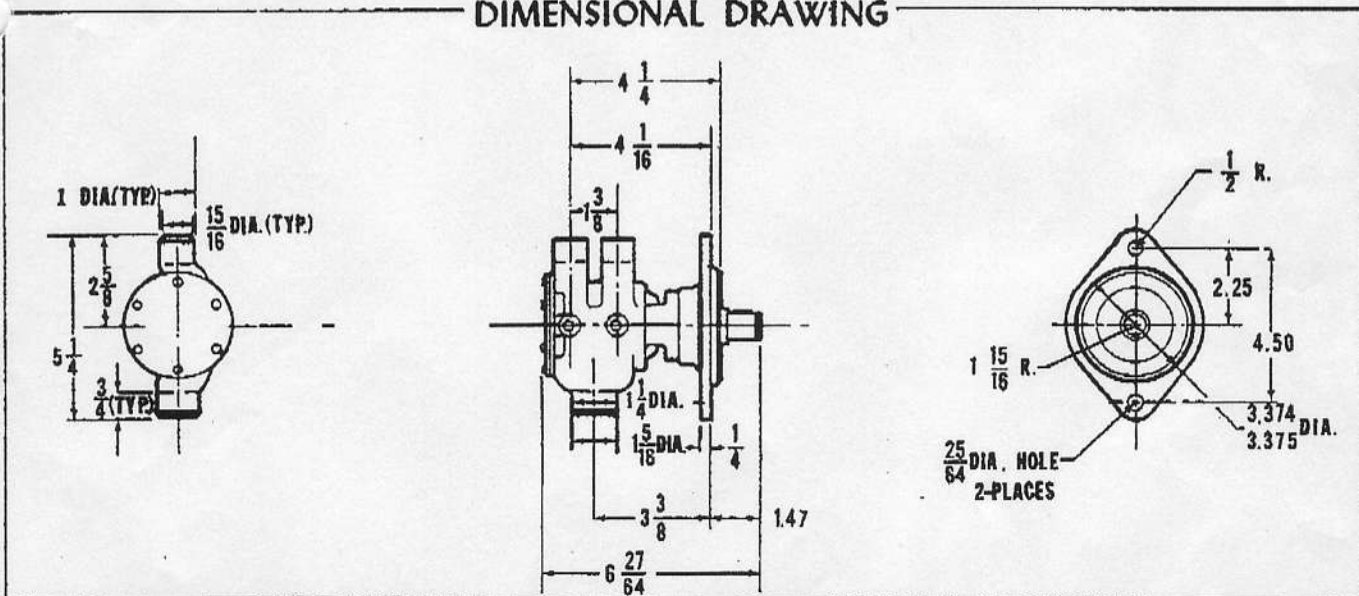

JABSCO® PUMP COMPANY
1485 DALE WAY • COSTA MESA, CALIFORNIA

JABSCO PUMP COMPANY, LTD.

Cadmore Lane

Cheshunt, Herts., England

F. 911 A

Supersedes

F. 911

PRINTED IN U.S.A.

8510F 1/2" Dual PumpPer Joan
8/31/76

The following parts are still available :

			<u>QTY</u>
GASKET =	3298-0000		1
IMP =	1210-0001		2
CAM / WEARPLATE ASSY	7607-0000		2
SHAFT SPACER -	NOT AVAILABLE		
SEAL	96080-0080		1
END COVER	11830-0000		1
BRG SEAL	913-0000		1
BEARING	92600-0060		1
Ret. ring	18724-0000		1
Service kit	90111-0001		