

JABSCO®

Model 777-SERIES

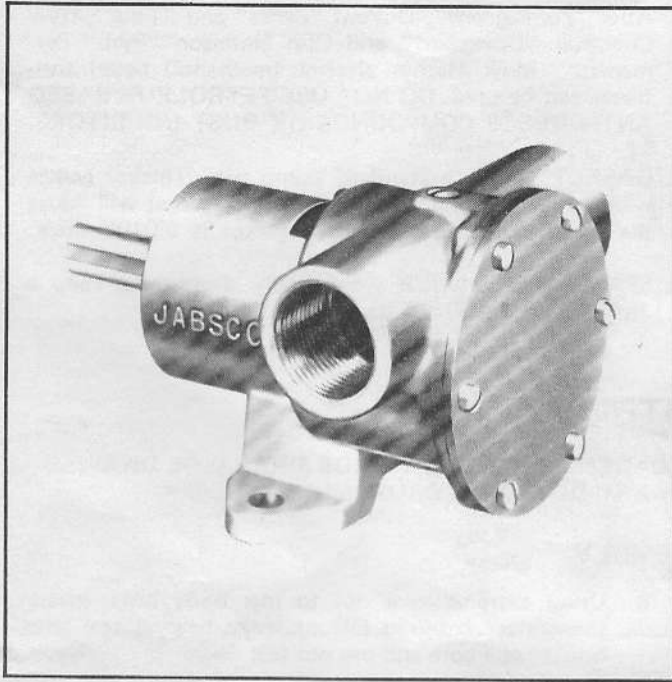

Self-Priming Pumps FEATURES

Body:	Bronze
Impeller:	Neoprene or Nitrile
Shaft:	Stainless Steel
Shaft Seal:	Mechanical Face Seal or Lip Type
Wearplate:	Replaceable
Bearings:	Shielded Ball Bearings
Ports:	1" NPT Internal
Weight:	5-3/4 lbs (2,61 kgs)

Model 777-SERIES

VARIATIONS AVAILABLE

MODEL NO.	DESCRIPTION
777-0001	Neoprene Impeller (Lip Seal)
777-0003	Nitrile Impeller (Lip Seal)
777-9001	Neoprene Impeller (Face Seal)
777-9003	Nitrile Impeller (Face Seal)
777-9051	Half Thickness Cam (Face Seal)

APPLICATIONS

MARINE: Pumping bilges, Washdowns, Circulating water in bait tanks, Utility dock-side pump, Engine cooling.

INDUSTRIAL: Circulating and transferring, Velocity-mixing, Pumping machine tool coolants, Return spill, Sump drainage, Chemicals, Pharmaceuticals, Soap, Liquors, Ink, Dyes, Alcohol, Dilute acids, Tanning liquors, Glycerine, Brine, etc.

FARMING: Pumping water for stock, Pumping water from shallow wells and cisterns, Pumping liquid ballast into tractor tires.

PLUMBING AND HOME EMERGENCY USE: Pumping out flooded basements, Cesspools, Sumps, Water heaters and water closets, Drains and sinks, Draining fishponds and pools.

OPERATING INSTRUCTIONS

1. **INSTALLATION** – Pump may be mounted in any position. The rotation of the pump shaft determines the location of the pump's intake and discharge ports. (Refer to dimensional drawing.) Pump is normally assembled at factory for clockwise rotation (looking at end cover). If counter clockwise rotation is desired, follow steps 1 and 2 of disassembly and step 11 of assembly instructions to change direction of impeller blade deflection under cam.

2. **DRIVE** – Belt or Direct with flexible coupling.

Belt Drive – Overtight belt load will reduce pump bearing life.

Direct Drive – Clearance should be left between drive shaft and pump shaft when installing coupling. Always mount and align pump and drive shaft before tightening the coupling set screw.

NOTICE: If pulley or coupling must be pressed on shaft, remove end cover and impeller to support shaft from impeller end during press operation. Do not hammer pulley or coupling on shaft; this may damage bearings or seal.

3. **SPEEDS** – 100 RPM to the maximum shown in the performance table. Consult the factory for operation at speeds above those shown. For longer pump life, operate at lowest possible speeds.

4. **SELF-PRIMING** – Primes at low or high speeds. For vertical dry suction lift of 10 feet, a minimum of 800 RPM is required. Pump will produce suction lift up to 22 feet when wetted. **BE SURE SUCTION LINES ARE AIR-TIGHT OR PUMP WILL NOT SELF-PRIME.**

5. **RUNNING DRY** – Unit depends on liquid pumped for lubrication. **DO NOT RUN DRY** for more than 30 seconds. Lack of liquid will damage the impeller.

OPERATING INSTRUCTIONS (Cont.)

6. **NOTICE** — Do not pump light fraction petroleum derivatives, solvents, thinners, highly concentrated or organic acids. Damage to pump may result. Consult Jabsco Chemical Resistance Table (available upon request from ITT Jabsco) or factory for proper body materials and impeller compounds. If corrosive fluids are handled, pump life will be prolonged if pump is flushed with water after each use or after each work day.
7. **PRESSURES**— Consult Head Capacity Table for recommended maximum for continuous operation. If pressures exceed those shown, consult the factory.
8. **TEMPERATURES** — Neoprene 45°-180°F (7°-82°C). Nitrile 50°-180°F (10°-82°C).
9. **FREEZING WEATHER** — Drain unit by loosening end cover. The following anti-freeze compounds can be used without any adverse effects to the neoprene impeller: Atlas "Permaguard", DuPont "Zerex" and "Telar", Dow Chemical "Dowguard" and Olin Mathison "Pyro" Permanent". Most Methyl alcohol (methanol) based anti-freeze can be used. **DO NOT USE PETROLEUM BASED ANTI-FREEZE COMPOUNDS OR RUST INHIBITORS.**
10. **GASKET** — Use a standard pump part. Thicker gasket will reduce priming ability. A thinner gasket will cause the impeller to bind. Standard gasket is 0.010" thick.
11. **SPARE PARTS** — To avoid costly shutdowns, keep a JABSCO Service Kit on hand.

SERVICE INSTRUCTIONS

CAUTION: PUMPS WHICH HAVE HANDLED CORROSIVE, CAUSTIC OR TOXIC FLUIDS SHOULD BE DRAINED AND COMPLETELY FLUSHED PRIOR TO SERVICING. FAILURE TO DO SO MAY CAUSE INJURY.

DISASSEMBLY

1. Remove end cover screws, end cover and gasket.
2. Grasp hub of impeller with water pump pliers and withdraw from body.
3. Remove cam screw and cam; clean Sealant from cam and body bore.
4. Remove wearplate.
5. Insert screwdriver between O D of outer bearing seal and bearing bore, and pry seal out.
6. Remove bearing to body retaining ring.
7. Press on impeller drive end of shaft to remove shaft and bearing assembly.
8. Using extreme care not to mar body bore, insert screwdriver between OD of inner bearing seal and bearing seal bore and pry out seal.
9. **Lip seal versions:** Press seal out of body towards impeller bore.
Face seal versions: Remove ceramic seal seat and seat gasket from shaft. Press carbon seal seat out of body towards impeller bore.
10. Remove bearing to shaft retaining ring.
11. Support bearing inner race, press on drive end of shaft to remove shaft from bearing. Do not attempt to remove bronze bushing which is pinned to shaft.
12. Inspect all parts for wear or damage and replace where necessary.

ASSEMBLY

1. Lubricate inner bearing seal lip with grease and press into body bearing seal bore with lip facing away from bearing bore.
2. Press shaft into bearing, using care to support inner race of bearing.
3. Install bearing to shaft retaining ring with flat side toward bearing.
4. **Lip seal versions:** Position slinger in body drain area. Insert splined end of shaft through bearing bore and guide slinger over shaft until bearing contacts body.
5. Pressing on bearing outer race, install bearing into bore.
6. Install bearing to body retaining ring in body groove with flat side toward bearing.
7. Lubricate outer bearing seal lip with grease and press into bearing bore until it is flush with the body.
8. **Lip seal versions:** Lubricate O D and lip of seal, then push into place, using care not to damage or cut seal lip. (Lip faces impeller bore.)
Face seal versions: Lubricate rubber grommet in ceramic seal seat with water and install on shaft, grommet toward bearing. Install seal (carbon toward ceramic seat) in seal bore and press flush with bottom of impeller bore.
9. Install wearplate in body bore, aligning slot in wearplate with dowel pin in body.
10. Apply a thin coat of sealant to cam screw threads and top side of cam and install in body with cam screw.
11. Lubricate impeller bore and end surfaces of impeller with a light coat of water pump grease and start impeller into bore with a rotary motion until splines engage, then push into bore.
12. Install gasket and end cover and secure with end cover screws.

EXPLODED VIEW

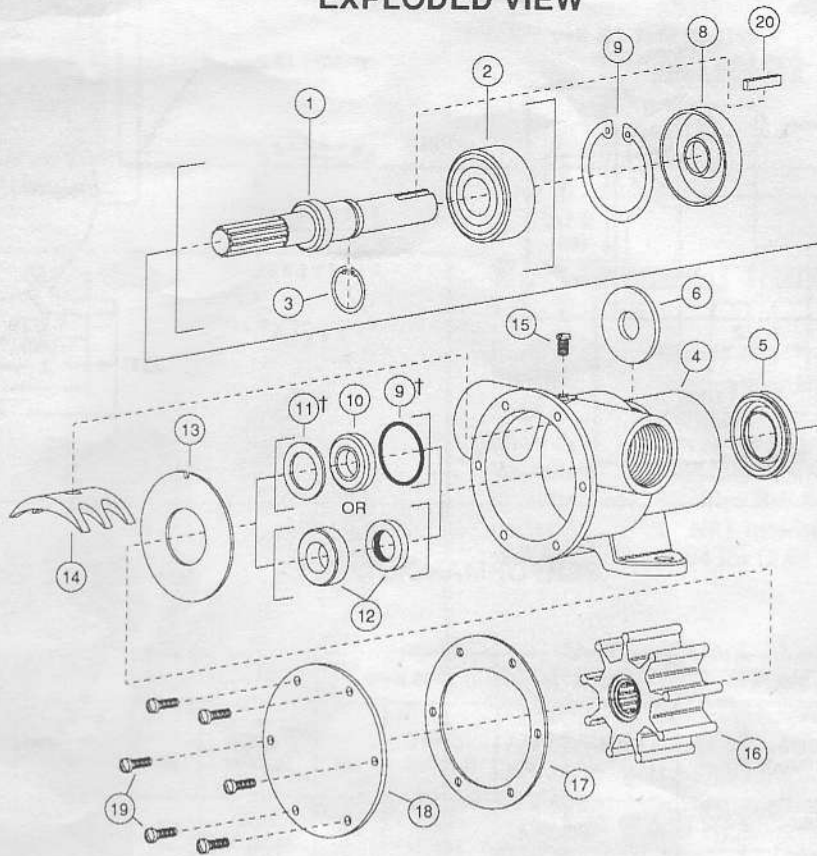

PARTS LIST

Key	Description	Model 777-0001	Model 777-0003	Model 777-9001	Model 777-9003	Model 777-9051
1	Shaft	6718-0000	6718-0000	6718-0000	6718-0000	6718-0000
2	Ball Bearing	92600-0060	92600-0060	92600-0060	92600-0060	92600-0060
3	Retaining Ring (Brg. to Shaft)	18713-0000	18713-0000	18713-0000	18713-0000	18713-0000
4	Body	798-0020	798-0020	798-0020	798-0020	798-0020
5	Bearing Seal (Inner)	913-0000	913-0000	913-0000	913-0000	913-0000
6	Slinger, used with Lip Seal only	3180-0000	3180-0000	-	-	-
7	Retaining Ring (Brg. to Body)	18724-0000	18724-0000	18724-0000	18724-0000	18724-0000
8	Bearing Seal (Outer)	914-0000	914-0000	914-0000	914-0000	914-0000
9	† * O-Ring	92000-0210	92000-0210	-	-	-
10	* Seal (Lip)	92700-0060	92700-0060	-	-	-
11	† Seal Spacer	3166-0000	3166-0000	-	-	-
12	* Seal (Face)	-	-	96080-0080	96080-0080	96080-0080
13	Wearplate	4156-0000	4156-0000	4156-0000	4156-0000	4156-0000
14	Cam (Brass)	934-0000	934-0000	934-0000	934-0000	2431-0000
15	Screw (Cam)	91004-0090	91004-0090	91004-0090	91004-0090	91004-0100
16	* Impeller - Neoprene, Brass Insert Nitrile, Brass Insert	920-0001	- 920-0003	920-0001	- 920-0003	- 920-0001
17	* Gasket	890-0000	890-0000	890-0000	890-0000	2432-0000
18	End Cover	11831-0000	11831-0000	11831-0000	11831-0000	11831-0000
19	Screw (End Cover)	91003-0010	91003-0010	91003-0010	91003-0010	91003-0010
20	Key	9215-0000	9215-0000	9215-0000	9215-0000	9215-0000
	Service Kit (Not Shown)	90010-0001	90010-0003	90118-0001	90118-0003	90118-0001

* Parts supplied in Service Kit.

† Used for models prior to August 1, 1964.

NOTE: 5915-0001, Hi Pressure Neoprene Impeller available; contact factory for application recommendations.

**DIMENSIONAL DRAWING
INCHES (MILLIMETRES)**

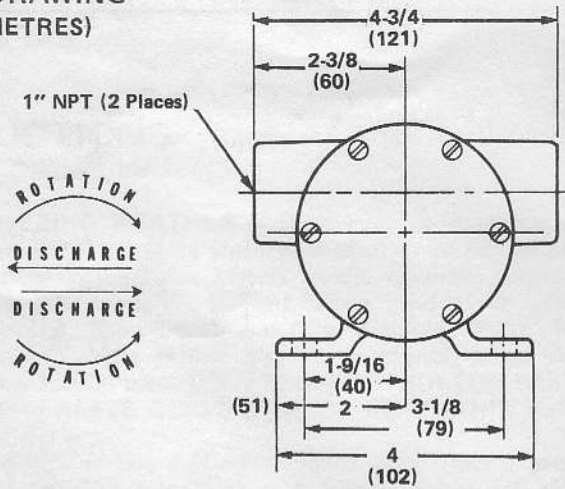
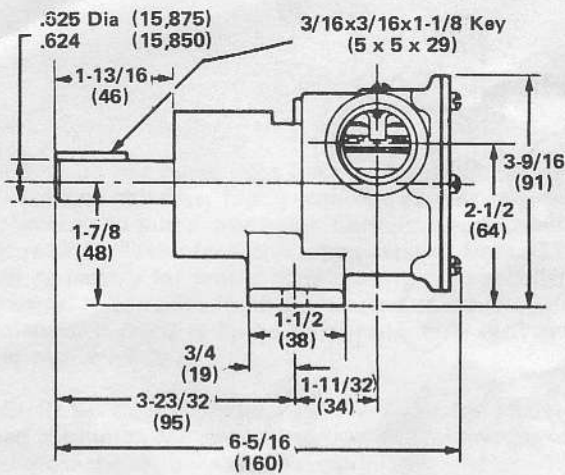

PERFORMANCE TABLES

Model 777-9001

TOTAL HEAD		500 RPM		1160 RPM		1750 RPM		2100 RPM		2750 RPM		3000 RPM	
PSI (kg/sq cm)	Feet of Water (Metres)	GPM (L/Min)	HP	GPM (L/Min)	HP	GPM (L/Min)	HP	GPM (L/Min)	HP	GPM (L/Min)	HP	GPM (L/Min)	HP
4.3 (0,3)	10 (3,0)	6.0 (22,7)	1/4	14.7 (55,6)	1/3	23.3 (88,2)	3/4	27.9 (105,6)	3/4	33.8 (127,8)	1-1/2	35 (132,5)	1-1/2
8.7 (0,6)	20 (6,1)	5.6 (21,2)	1/4	13.8 (51,9)	1/2	22.0 (83,3)	3/4	26.8 (101,3)	1	32.9 (124,5)	1-1/2	34.3 (129,8)	1-1/2
17.3 (1,2)	40 (12,2)	4.6 (17,4)	1/4	11.5 (43,5)	1/2	19.3 (73,1)	3/4	23.9 (90,5)	1	30.5 (115,5)	1-1/2	32.5 (123,0)	1-1/2
26.0 (1,8)	60 (18,3)	—	—	7.8 (29,5)	3/4	15.5 (58,7)	1	19.2 (72,5)	1-1/2	26.1 (98,8)	2	29.3 (110,9)	2
34.6 (2,4)	80 (24,4)	—	—	—	—	10 (37,9)	1	13.2 (49,8)	1-1/2	19.9 (75,3)	2	23.5 (89,1)	2

Model 777-9051

TOTAL HEAD		500 RPM		1160 RPM		1750 RPM		2100 RPM		2750 RPM		3000 RPM	
PSI (kg/sq cm)	Feet of Water (Metres)	GPM (L/Min)	HP	GPM (L/Min)	HP	GPM (L/Min)	HP	GPM (L/Min)	HP	GPM (L/Min)	HP	GPM (L/Min)	HP
4.3 (0,3)	10 (3,0)	4.0 (15,1)	1/4	8.7 (32,9)	1/4	13.6 (51,5)	1/2	16.7 (63,2)	3/4	22.3 (84,4)	1	24.0 (90,8)	1
8.7 (0,6)	20 (6,1)	3.4 (12,9)	1/4	8.0 (30,3)	1/3	12.8 (48,4)	1/2	15.8 (59,8)	3/4	21.2 (79,9)	1	23.2 (87,8)	1-1/2
17.3 (1,2)	40 (12,2)	2.0 (7,6)	1/4	5.8 (22,0)	1/3	10.4 (39,4)	3/4	13.5 (51,1)	3/4	18.5 (70,0)	1	22.0 (83,3)	1-1/2
26.0 (1,8)	60 (18,3)	—	—	—	—	7.0 (26,5)	3/4	10.0 (37,9)	1	14.5 (54,9)	1-1/2	16.0 (60,8)	1-1/2

NOTE: Table shows approximate head-flow for new pump, with a neoprene impeller, in U.S. gallons per minute and litres per minute. For a nitrile impeller, reduce values by 10%. Progressively longer life may be expected as operating pressures and speeds are reduced. Factory application engineering assistance is recommended for shaded area. High starting torque motors are required. Pump starting torque in dry condition (no fluid in pump body) is 45.7 inch-pounds and in wet condition (fluid in pump body) is 39.0 inch-pounds.

ITT Jabsco

ITT Fluid Technology Corporation

1485 Dale Way, P.O. Box 2158, Costa Mesa, Ca 92628-2158

Tel: (714) 545-8251; Fax: (714) 957-0609

Bingley Road, Hoddesdon, Hertfordshire EN11 0BU, England

Tel: 0992-467191; Tlx: 26351 G; Fax: 0992-467132