

JABSCO®

Marine Engine
Cooling Pumps

SERVICE INSTRUCTIONS for Major Service Kits

General Motors Model Number 5122599
formerly 5197222

JabSCO Model Number 6980
formerly MSK - 65

DISASSEMBLY

1. Remove end cover screws, end cover and gasket.
2. Remove impeller. To facilitate removal use water pump pliers grasping the hub, or two pair regular pliers grasping opposite blades.
3. Remove cam screw, cam and wearplate.
4. Remove seal with hooked wire. Remove seal seat and gasket.
5. Remove lock nut, lock washer, washer and gear.
6. Remove bearing-to-body retaining ring.
7. Pressing on impeller end of shaft, remove shaft and bearing assembly from body.
8. Supporting bearing inner race, press shaft through bearing.
9. Remove slinger from drain area.
10. Using extreme care not to mar body bore, insert screwdriver between O.D. of inner bearing seal and pump bore and pry out the seal.

NOTE: Inspect all parts for wear or damage and replace where necessary.

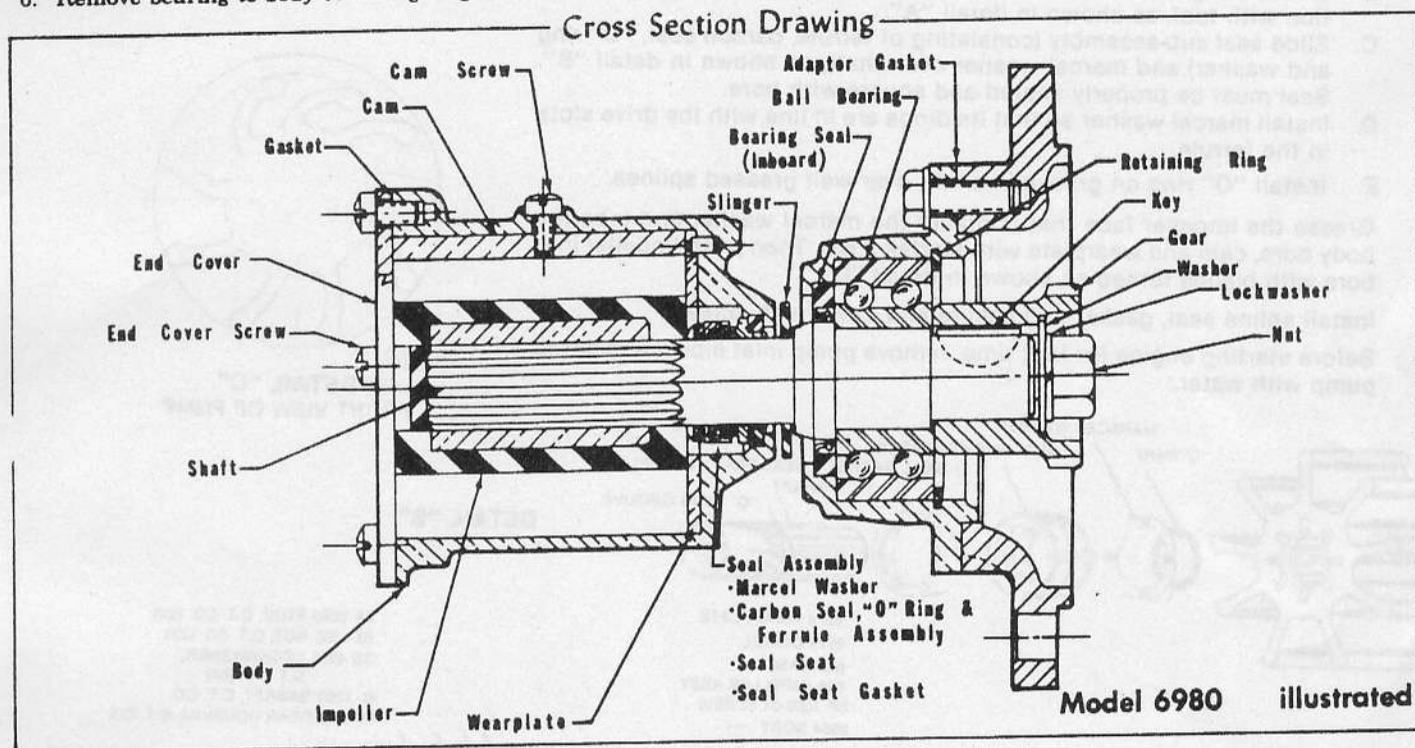

ASSEMBLY

1. Lubricate inner bearing seal with grease and press into body bearing seal bore lip facing bearing bore.
2. Press shaft into bearing using care to support inner race of bearing.
3. Place slinger in drain area on top of seal bore.
4. Coat shaft shoulder liberally with Marfak 2HD grease and insert spline end of shaft through bearing seal and slinger until bearing contacts body.
5. Pressing on bearing outer race, slowly press bearing into bore, rotate shaft during press operation to prevent damage to bearing seal lip.
6. Install bearing-to-body retaining ring in body groove with flat side toward bearing.
7. Install key in shaft key slot.
8. Install gear, washer, lock washer and lock nut.
9. Install wearplate and impeller bore aligning slot in wearplate with dowel pin in body.
10. Permatex screw threads, top side and back end of cam and install in body with cam screw.
11. Lubricate seal gasket of seal seat and gasket assembly with water and insert in seal bore of body with polished surface facing outward. Care must be taken not to mar or scratch seal seat face. Installing this assembly with a slight rotary motion will insure seating the gasket firmly in the cavity.
12. Install balance of seal assembly with polished carbon seal face against seal seat. The seal assembly consists of the carbon seal ring and "O" ring which are contained within the metal ferrule. The metal ferrule has a neoprene washer cemented to its outside face against which the Marcel spring washer is positioned.
13. Lubricate impeller bore with a light coat of Marfak 2HD grease and start impeller into bore with a rotary motion until splines engage, then push into bore.
14. Install gasket and end cover and secure with end cover screws.

NOTE: It is advisable to position the Marcel spring washer so that the drive points are aligned with the indentations in the ferrule face.

ASSEMBLY INSTRUCTIONS

- Step 1. Remove protective wrapping from (Jabsco) shaft assembly, except the separate wrapping at splined end of shaft. Make sure that pilot end of 4L2178 shaft, mounting face of 4L1282 gear, as well as pilot hole in mounting face of (Jabsco) shaft, are clean and undamaged.
2. Install (Jabsco) shaft to (C.T. Co.) gear with (C.T. Co.) bolts and locks. Important: Leave protective wrapping at splined end of (Jabsco) shaft in place until after assembly of pump body to engine housing. This will prevent the splines from damaging the bearing seal. (Already installed in the pump body.)
- Step 3. Install (Jabsco) pump sub-assembly over pump shaft to timing gear housing with 4L1269 gasket, 1D4566 bolts, 2A2090 studs, 3B4508 lockwashers and 1B4205 nuts.
- Step 4. Detach slinger from body and position in center of drain area.
- Step 5. Remove protective wrapping from splined end of shaft.
- Step 6. Assemble pump seal as follows:
- Sparsely lube gasket O.D. of seal gasket and seal seat assembly with water pump grease.*
 - Slide seal gasket-seat assembly on shaft and force firmly into position with tool, as shown in detail "A".
 - Slide seal sub-assembly (consisting of ferrule, carbon seal, "O" ring and washer) and marcel washer over shaft, as shown in detail "B". Seal must be properly seated and square with bore.
 - Install marcel washer so that its dings are in line with the drive slots in the ferrule.
 - Install "O" ring on groove in shaft, over well greased splines.
- Step 7. Grease the impeller face that contacts the marcel washer and lube the body bore, cam and wearplate with Marfak 2 HD. Then push impeller into bore with blades turned as shown in detail "C".
- Step 8. Install spline seal, gasket and secure end cover with screws.
- Step 9. Before starting engine for first time, remove pump inlet elbow and prime pump with water.

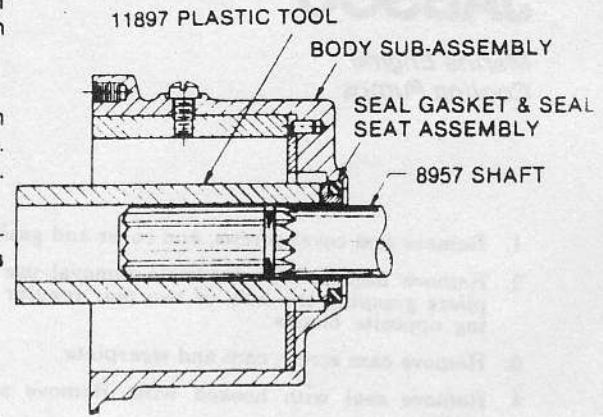

DETAIL "A"

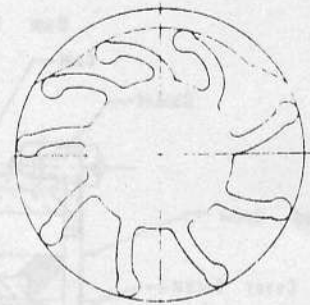

DETAIL "C"
FRONT VIEW OF PUMP

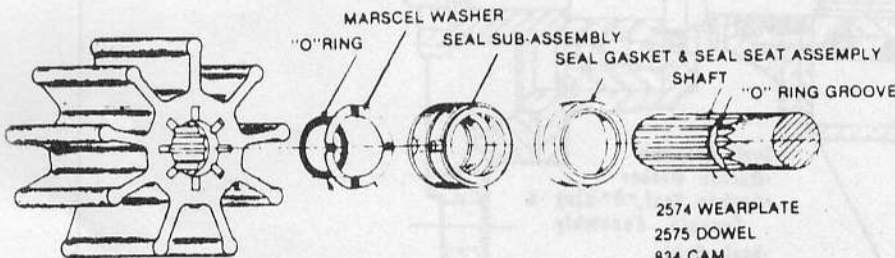

DETAIL "B"

2574 WEARPLATE
2575 DOWEL
834 CAM
836 IMPELLER ASSY
SP 1005-04 SCREW
8954 BODY

2A 2090 STUD, C.T. CO. (2X)
1B 4205 NUT, C.T. CO. (2X)
3B 4508 LOCKWASHER,
C.T. CO. (4X)
4L 1269 GASKET, C.T. CO.
TIMING GEAR HOUSING, C.T. CO.

NOTES:

1. BODY SUB-ASSEMBLY CONSISTS OF THE FOLLOWING PARTS:
- 8954 PUMP BODY
 - 818 BEARING SEAL
 - 3181 SLINGER
 - 2575 DOWEL PIN
 - 2574 WEARPLATE
 - 834 CAM
 - SP 1005-04 CAM SCREW

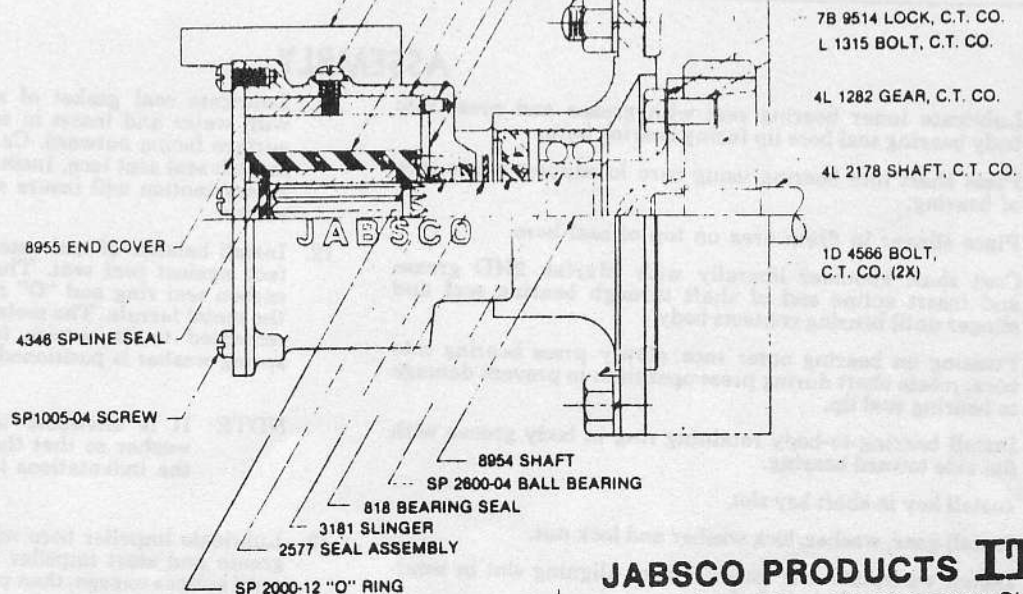

7B 9514 LOCK, C.T. CO.
L 1315 BOLT, C.T. CO.
4L 1282 GEAR, C.T. CO.
4L 2178 SHAFT, C.T. CO.
1D 4566 BOLT,
C.T. CO. (2X)

JABSCO PRODUCTS **ITT**

Marine and Recreation Components Division
International Telephone and Telegraph Corporation
1485 Dale Way, Costa Mesa, California 92626

Telephone: (714) 545-8251

43000-0368

*Care should be exercised not to put any grease on the face of the seal seat.