

EXPLODED VIEW

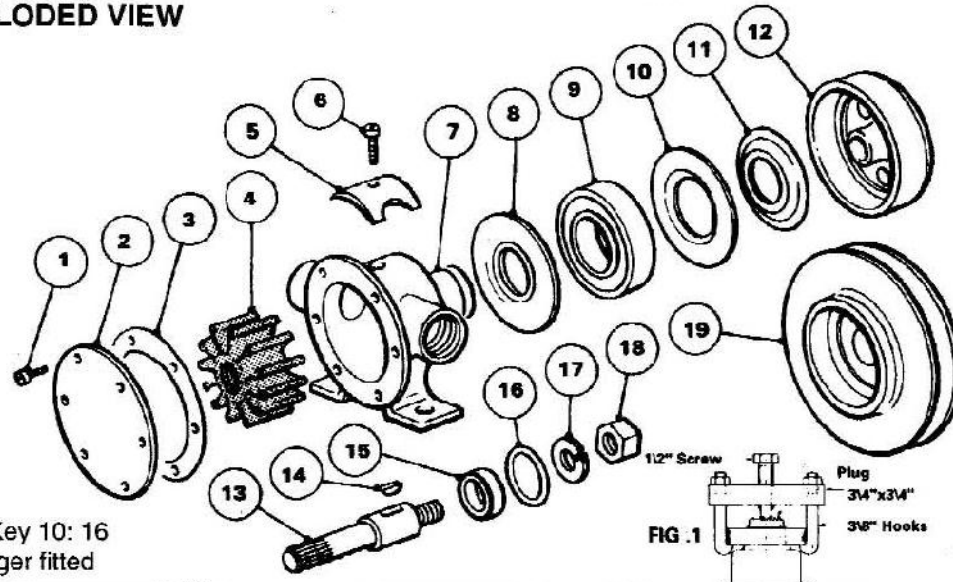

Note Key 10: 16 no longer fitted

PARTS LIST

Key	Description	Qty	Part No	Key	Description	Qty	Part No
1	Endcover Screw†	6	SP1003-09	12	Bearing Housing (Notes 6490-200, -205)	1	1740
2	Endcover	1	3953	13	Shaft 6490-122 to 231	1	1737-207*
3	Gasket†	1	64C6		Shaft 6490-200, -205		1737-24-01
4	Impeller†	1	1210-0001B	14	Key	1	SP1402-06*
5	1/2 Cam 6490-210, -222, -223	1	490	15	Shaft Seal†	1	SP2731-21
	-122, -123, -200			16	'O' Ring	1	SP2030-21
	Cam 6490-231, -224, -225			17	Seal Spacer	1	3186
	-124, -125, -205			18	Nut	1	SP1085-25*
6	Cam Screw (490 Cam)	1	SP1003-01	19	Pulley 6490-210, -231		9487-05
	Cam Screw (10336 Cam)	1	SP1003-09		Pulley 6490-122, -124, -222, -224	1	22299*
7	Body	1	6/94-200	4	Roller 6490-123, -125, -223, -225		22299*
8	Bearing Shield	1	3076	20	Lockwasher (Not shown)	1	SP1637-04
9	Bell Bearing	1	SP2600-09	Service Kit No SK 255-01 Contains Parts marked †			
10	Rotating Shield	1	1161				
11	Stationary Slinger	1	1554				

SERVICE INSTRUCTIONS

Dis-Assembly Inspect all parts for wear or damage and replace if necessary

1. Remove endcover screws, endcover and gasket.
2. Remove impeller.
3. Remove shaft retaining nut from pulley and remove shaft.
4. Remove seal, seal spacer and "O" ring using two pieces of hooked wire.
5. Loosen cam screw and remove cam, (clean off any old jointing compound).
6. Remove pulley from bearing, heat o.d. of pulley uniformly with gas flame.
7. Remove stationary slinger and rotating shield.
8. Remove bearing (see fig 1). With shaft and bearing housing removed according to service instructions, insert plug as shown. Attach two forks on bearing 180 degrees apart. Tighten extractor screw against plug, extracting bearing. Plug should be solid steel 7/8" o.d. x 9/16" long with one end slightly countersunk to match extractor screw.
9. Remove bearing shield.

* To update obsolete models replace shaft and pulley

Shaft 1737-224 Replace by shaft 1737-207, key SP1402-06, Nut SP1085-25
 Pulley 10758 Replace by pulley 22299 for Models 6490-152, -252, -154, -254
 Pulley 9487-04 Replace by pulley 22298 for Models 6490-153, -253, -155, -255
 Note: Replacement shaft for models 6490-200 & 205
 Is Part No 1737-24-01, Key locknut & washer not required.

INSTALLATION DRAWING

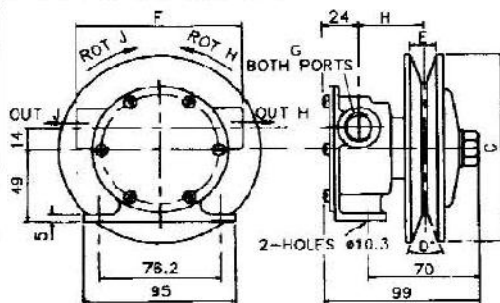

Model No	PULLEY DETAILS				PORT DETAILS			Notes: 6490-200 Overall Dimensions L 111mm W 105mm H 92mm Other Dimensions Consult Distributor or Factory H ic) 159 = 3.8 c) 127 = 41.3
	PCC for Belt Section	A	B	Z	Ø	Angle	Width	
6490-122	103	117	-	127	38°	17	156	25mm dia Tube
6490-123	135	145	-	159	38°	17	156	25mm dia Tube
6490-210	-	-	155	159	36°	10	105	1/2" BSP
6490-222	103	117	-	127	38°	17	105	1/2" BSP
6490-223	135	145	-	159	38°	17	105	1/2" BSP

Assembly

1. Install bearing shield over bearing shoulder with flange facing away from impeller.
2. Press bearing on body until it bottoms. Note: Press on inner race of bearing whilst supporting the pump at the impeller end.
3. Install rotating shield with dimple facing away from bearing. Install stationary slinger, with recessed side away from bearing.
4. Heat pulley to approximately 135°C in oven and drop over bearing. Pulley will immediately shrink upon contact with bearing therefore it must be positioned quickly. Take care not to "cock" the housing. Apply slight pressure to the pulley whilst cooling. Note: An ordinary domestic oven can be used. Approximately 10-15 minutes in oven at full power will usually heat the housing sufficiently.
5. Coat cam screw threads and top of cam with a non setting compound. Install in body.
6. Refit shaft and key from front end of pump and secure to pulley with nut and washer.
7. Fit "O" ring and seal spacer. Note: If original shaft is being refitted and shaft is worn do not replace seal spacer.
8. Lightly grease shaft splines, place seal over shaft, with spring facing towards impeller. Make sure that the seal is pushed right home.
9. Install impeller assembly on shaft with a rotary motion until splines engage then push into bore.
10. Install gasket, endcover, and secure with endcover screw.