

PAR™

ELECTRIC WATER SYSTEM PUMPS

MODEL 37215-Series

AUTOMATIC MULTI-FIXTURE

PRODUCT DATA

MODEL 37215-SERIES

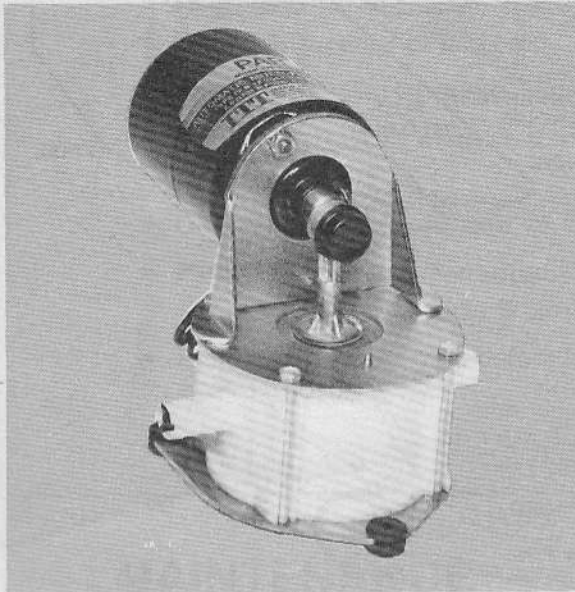

FEATURES

- Self-Priming
- Diaphragm Design Allows Dry Running
- Built-in Discharge Check Valve
- Low Current Draw
- Built-in Hydraulic Pulsation Dampener
- Meets USCG Electrical Regulation Title 33, Chapter I, Section 183.410
- IAPMO Approved

SPECIFICATIONS

	U.S. GPM	Liters/min.	Imp. GPM
Open Flow:	2.1	7.9	1.7
Cut-in Pressure:	16 PSI Nom. (1.1 kg/cm ²)		
Cut-off Pressure:	30 PSI Nom. (2.1 kg/cm ²)		
Ports:	Slip-on 1/2" or 5/8" I.D. Hose		
Vert. Dry Suction Lift:	5 feet (1.52M)		
Approval:	IAPMO Type IV		
Approx. Ship. Weight:	5 Lbs. (2.3 kgs.)		

APPLICATION

A PAR automatic water system pump designed for smaller, self contained recreational vehicles and pleasure boats. This pump is automatic – when a faucet is opened, the pump begins operation instantly to provide a constant flow from tank to faucet. Closing the faucet automatically discontinues pump operation. The Model 37215-Series pump is especially suited for small distribution systems.

DIMENSIONAL DRAWING

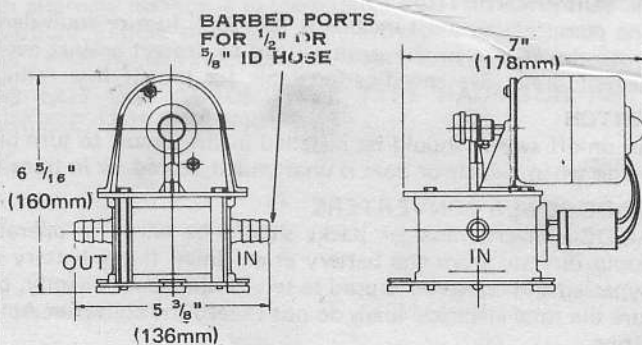

STANDARD MODELS

Model	Voltage	Nom. Amp Draw	Fuse Rating	
			"Slo-Blo"	Normal
37215-1000	12 VDC	5.5	6 1/4 Amp	7 Amp
37215-1010	24 VDC	4.0	4 Amp	5 Amp

JABSCO PRODUCTS **ITT**

INSTALLATION

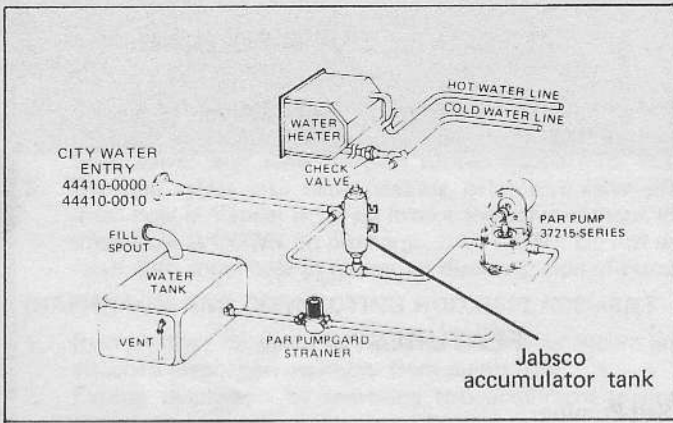

MOUNTING

PAR diaphragm pumps are self-priming. They may be located above or below the fresh water tank. The pump is equipped with vibration pads which are most effective when the pump is mounted upright on a solid surface.

PLUMBING

To minimize water pressure drop, the size of water supply line should not be less than sizes shown in the table below. Valves, elbows, etc., used should be the same size as pipe or tubing. Use gate valves only. Fresh water tank must be vented.

MINIMUM PIPING SIZE

Supply Line Length	Tubing I.D.	Pipe Size
Less than 48"	1/2"	3/8"
48" or more	5/8"	1/2"

PRESSURE REGULATOR. It is recommended that systems having a connection for a city water entry be equipped with a pressure regulating check valve set at approximately 35 PSI. This valve automatically regulates the incoming water pressure to avoid damage to the pump and plumbing from excessive pressures. PAR Models 44410-0000 (permanent flush mount) and 44410-0010 (in-line) pressure regulating valves are recommended for this purpose.

CHECK VALVE

PAR pumps are designed to withstand normal working pressures. However, higher pressures are sometimes encountered with unregulated water hookups. Models 37215-1000/-1010 features a built-in port check valve to protect the pump. An additional check valve should be installed in the cold water inlet of the water heater to minimize heat transfer to the cold water line and isolate excessive pressure from the heater in case of relief valve failure. PAR offers qualified check valves, Models 34344-0000, 35027-0000, and 35195-0000.

SUCTION FILTER. A PAR Pumpgard Model 36400-0000 (strainer/filter) is recommended installed between the pump and fresh water tank. It helps prevent valve clogging caused by foreign material entering the pump.

WATER PURIFIER. Water purifiers should be installed with separate outlets for drinking water use only. Many purifiers cause excessive back pressure.

ACCUMULATOR TANK. The use of an accumulator tank (Jabsco Model 12573-0000), although not required, is recommended for a more effective water distribution system. It eliminates "water hammer", stores pressure to allow a limited use of water without restarting pump (desirable at night-time), assures a constant even stream of water at faucets farthest from pump and prolongs pump life by cutting down rapid start/stop operation.

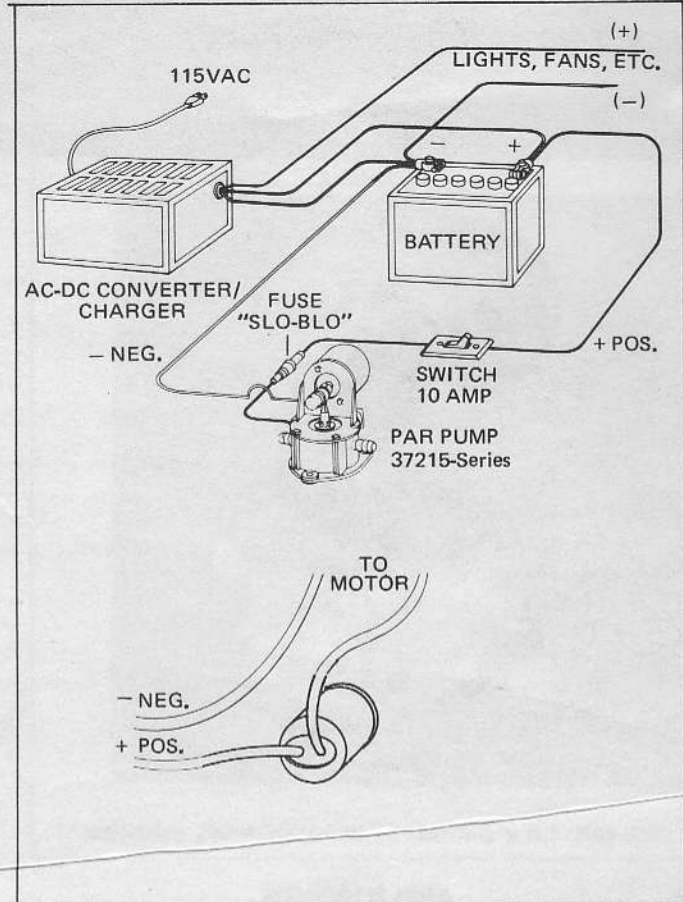

WIRING

Pump should be wired in an independent circuit according to the following chart:

WIRE SIZE CHART (A.W.G. - COPPER)

Length of circuit in feet (sum of + pos. & - neg. wire lengths).

Voltage	Up to 80'	80' to 100'	100' to 150'
12 Volts Two Wire	14	12	10
24 Volts Two Wire	16	14	14

Above wire size recommendation is based on pump load only. If other electrical fixtures share common service with the pump, larger wire sizes must be used.

MOTOR PROTECTION

The pump wiring must include a "Slo-Blo" fuse or equivalent protective device in the positive lead to protect against over-current draw. See specification table for proper fuse rating.

SWITCH

An on-off switch should be installed in the circuit to turn off pump when vehicle or boat is unattended, stored, or in transit.

AC-DC POWER CONVERTERS

AC-DC converter/charger packs should be wired to operate pump directly from the battery at all times. If the battery is bypassed and converter is used to service the pump directly, be sure the total electrical loads do not exceed the converter Amp rating.

VOLTAGE CHECK

After installation, check the voltage at the pump motor. It is important that voltage is checked when pump is operating along with all the inside electrical fixtures. Full voltage must be available at the pump motor at all times.

OPERATION

- Check level of water in tank.
- Check all strainers or any aerators and clean thoroughly.
- Open all faucets, hot and cold.
- Turn on power to pump and wait for hot water tank and water lines to fill.
- Close each faucet when it starts to deliver a steady stream of water (close cold water faucet first).
- Observe the pump. Check to be sure pump stops soon after closing last faucet.
- Pump is now ready for automatic operation. It will start when a faucet is opened and stop when the faucet is closed.
- Relieve system pressure before hooking up to city water.

MAINTENANCE

WINTER STORAGE. PAR pumps, with their unique pulsation dampener, will withstand frozen water without damage, provided the system is not under pressure prior to freezing. To prevent accidental damage, the entire water system should be protected from freezing during winter storage. This requires complete draining, using the following directions and/or vehicle manufacturers instructions:

1. Open all faucets and drains and allow pump to empty water tank and intake line. Run the pump dry for 1 to 2 minutes before turning off.
2. With all drains open, blow air through city water entry. Allow time for the water heater to empty.
3. Disconnect discharge and intake hoses from the pump. Start the pump and allow to run until all water is expelled from unit. (Running dry will not harm the pump.)
4. Reconnect the hoses, close the drains but leave faucets open. The water distribution system is now dry and ready for winter storage.

An alternate method is to use potable water system anti-freeze solution. Follow directions of anti-freeze manufacturer, and use a PAR Winter Protection Kit Model 44610-0000.

DO NOT USE AUTOMOTIVE TYPE RADIATOR ANTI-FREEZE. IT IS POISONOUS.

TROUBLE SHOOTING

Problems	Causes
Pump operates but no water flows through faucet	—Low water level in tank. —Suction line clogged or kinked. —Loose hose clamps or fittings in suction line.
Pump cycles on and off although all faucets are closed.	—Water leak in plumbing. —Water leak in flush toilet valve. —Internal leak in pump. —Outlet valve not sealing.
Pump operates roughly and has excessive noise and vibration.	—Flow through intake line is restricted, kink in hose. —Pump mounted on flimsy board. —Deformed or ruptured pulsation dampener in pump. —Worn connecting rod bearing.
Pump fails to start when faucet is opened.	—No voltage to pump. —Blown fuse. —Clogged piping. —Kink in outlet line. —Defective pressure switch.
Pump fails to stop when faucets are closed.	—Empty water tank. —Outlet valve not sealing. —Air in system. —Very low voltage. —Defective pressure switch.

CAUTION: Before servicing pump, turn off power and open faucets to relieve pressure in water system.

SERVICE

VALVES REPLACEMENT

1. Remove four tie down screws.
2. Expose valves by lifting motor mount from pump base. Remove valves from pockets. Clean all foreign materials from valves and seats. Inspect rubber flappers for cuts.
3. Reinstall valves into same pockets, being sure valve with small hole in flapper is UP on intake and valve without the small hole is DOWN on discharge. CAUTION: Do not use valve with small hole in rubber on discharge side of pump.

DIAPHRAGM AND CONNECTING ROD REPLACEMENT

1. Remove four tie down screws then lift motor mount and attached diaphragm assembly from pump base.
2. Expose diaphragm by removing two diaphragm retainer screws and detaching retainer. To disengage connecting rod, slip off of eccentric.
3. Remove diaphragm screw to separate diaphragm and plates from connecting rod. Inspect diaphragm for cuts and ruptures. Check connecting rod assembly for breaks, cracks or excessive wear on rod and bearing. If rod is to be reused, remove cover and pack built-in reservoir with automotive chassis lube. Original lubricant normally lasts lifetime of pump.
4. When reassembling, be sure to align diaphragm and connecting rod so that eccentric slips straight into connecting rod and diaphragm rests squarely on diaphragm retainer.

PULSATION DAMPENER REPLACEMENT

1. Remove four tie-down screws and one bottom plate screw to separate bottom plate from base.
2. Pull out rubber pulsation dampener from base. Inspect for excessive deformation, ruptures and cuts.
3. When installing new dampener, check that its three-rib section is placed in the discharge side of the pump. Be sure that flange is well-seated to effect a proper water and air seal.

PRESSURE SWITCH REPLACEMENT

1. Disconnect wires from pressure switch.
2. Unscrew switch from base.
3. Thread switch with sealing washer into pump base, metallic side of washer facing switch. Do not over-tighten.
4. Rewire one lead to motor, other to fused circuit.

MOTOR REPLACEMENT

1. Disconnect one motor wire from pressure switch terminal, the other from splice connector.
2. Loosen eccentric set-screw on motor shaft.
3. Remove two motor nuts and pull motor away from motor mount, while holding back eccentric/connecting rod assembly.
4. When installing new motor, adjust eccentric on motor shaft so little or no contact is made between teflon washer and connecting rod bearing.
5. Rewire motor leads to terminal on pressure switch, and splice connector.

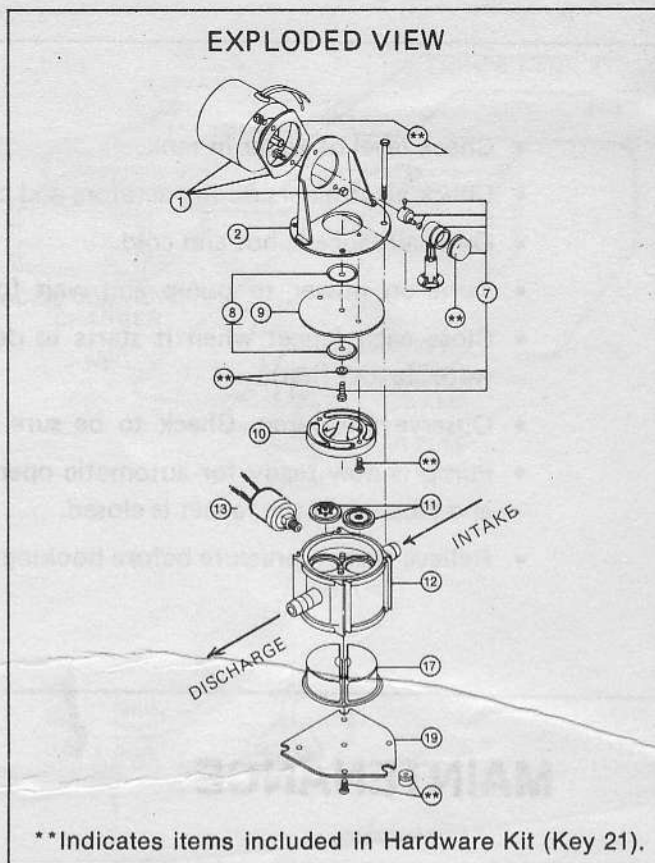

PARTS LIST

37215-Series

Key	Part Description	Part Number	Qty
1	Motor Kit 12 Volt D.C. . . .	30201-0000	1
1	Motor Kit 24 Volt D.C. . . .	30201-0010	1
2	Motor Mount	35812-0000	1
7	Connecting Rod Assembly	30033-0000*	1
8	Diaphragm Plate	35479-0000	2
9	Diaphragm	37174-0000*	1
10	Retainer	35799-0000	1
11	Valve Set (Inlet & Outlet)	30130-0000*	1 Set
12	Base	35787-1000	
13	Pressure Switch	37121-0000 - See Note 2	1
		44814-0000 - See Note 3	1
17	Pulsation Dampener	37179-0000*	
19	Bottom Plate	35798-0000	1
21	Hardware Kit	37168-0000	1 Set
	Service Kit*	30127-0000	

*Indicates Parts Contained in Service Kit.

NOTE 2 - Includes Switch and Conversion Kit to Mount New Style Onto Older Style -J and -0000 Pumps.

NOTE 3 - Replacement Switch Only for -1000 Series Pumps. Meets USCG Electrical Standards

JABSCO PRODUCTS **ITT**

Marine and Recreation Components Division
International Telephone and Telegraph Corporation
1485 Dale Way, Costa Mesa, California 92626

Telephone: (714) 545-8251