

JABSCO®

Models 30520-5XXX 30520-3XXX

Models 30520-5XXX, 30520-3XXX

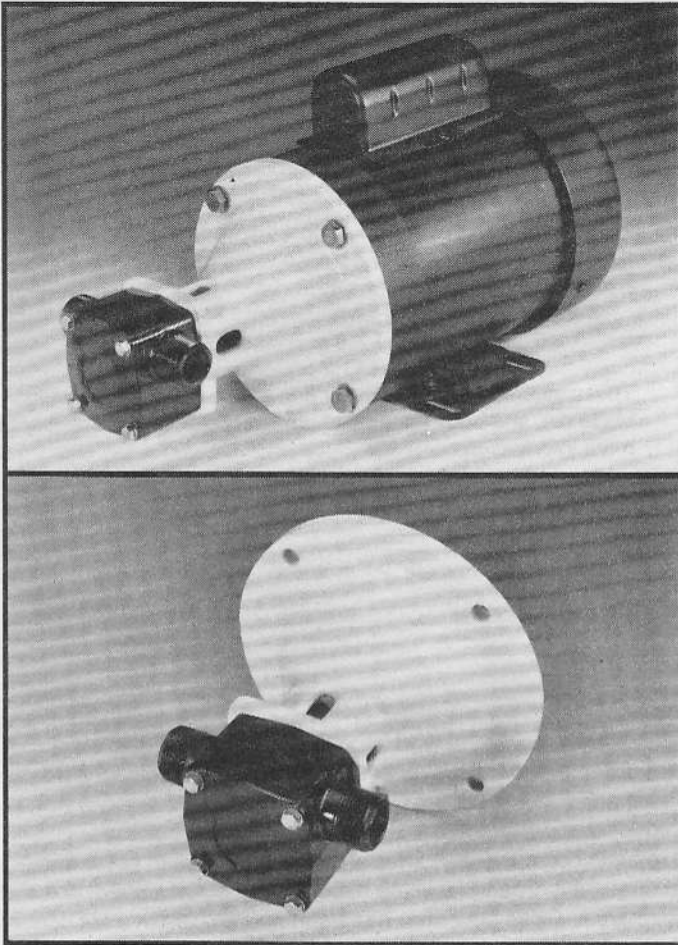

SELF-PRIMING PUMPS

FEATURES

- Pump Type:** 30520-5XXX Close Coupled
30520-3XXX Pump Head
- Body:** Epoxy Plastic
- Impeller:** Neoprene, Nitrile, Viton*
- Shaft Seal:** Mechanical, Carbon-on-Ceramic or Tungsten Carbide; Nitrile or Viton
- Ports:** 1" NPT External
- Shaft:** Epoxy Plastic Covered Stainless Steel
- Motor:** 230 Vac, Single Phase, 60 Hz, 2 HP, 1750 RPM, TEFC, 145 TC Frame, C-Face, Overload Protected, Capacitor Start.
- Weight:** 30520-5XXX 54.5 lbs (24,7 kg) Approx.
30520-3XXX 10.5 lbs (4,8 kg) Approx.

⚠ MOTOR WARNING



MOTOR CAN SPARK.
EXPLOSION & DEATH
CAN OCCUR.
DO NOT USE WHERE
FLAMMABLE VAPORS
ARE PRESENT.

APPLICATIONS

INDUSTRIAL: Circulating and transferring corrosive liquids. Returning spilled liquids to process. Transferring foaming solutions with entrained air, such as soaps and detergents. Sampling and pilot plant installations. Handles pure solutions, acids, alkalies, photo chemicals, dyes, detergents, waxes, gels, solutions with suspended solids and emulsions.

METAL PLATING: Filtration of plating solutions. Filling and emptying vats. Adding chemicals for Ph balance.

PHARMACEUTICAL: Processing lab solutions, medicines, lotions and preparations. Filtering pharmaceutical solutions.

AGRICULTURAL: Transferring liquids fertilizers, herbicides and pesticides.

WARNING: Do not pump flammable solvents, thinners, or gasoline as explosion may result causing property damage, severe personal injury or death.

VARIATIONS AVAILABLE

MODEL	DESCRIPTION
30520-5001 30520-3001	Standard Pressure, Neoprene Impeller, Carbon Seal
30520-5003 30520-3003	Standard Pressure, Nitrile Impeller, Carbon Seal
30520-5004 30520-3004	Standard Pressure, Viton Impeller, Carbon Seal
30520-5101 30520-3101	Standard Pressure, Neoprene Impeller, Tungsten Carbide Seal
30520-5103 30520-3103	Standard Pressure, Nitrile Impeller, Tungsten Carbide Seal
30520-5104 30520-3104	Standard Pressure, Viton Impeller, Tungsten Carbide Seal

Viton* is a trademark of E.I. Du Pont de Nemours and Company.

OPERATING INSTRUCTIONS

1. **INSTALLATION** – Pump may be mounted in any position. The rotation of the pump shaft determines the location of the pump's intake and discharge ports. Refer to dimensional drawing. Pump is normally assembled at factory for clockwise rotation (looking at end cover). If counter clockwise rotation is desired, follow steps 1 and 2 of disassembly and step 7 of assembly instructions to change direction of impeller blade deflection under cam.
2. **MOTOR SELECTION** – Pump head is designed to fit a 145 TC Frame NEMA C-face motor. Motor should be rated 2 horsepower at 1750 RPM with a service factor of one. Due to high bearing loads, motor should be ball bearing equipped with the front bearing locked against axial movement. Motor should be capacitor start and foot mounted.
3. **SPEEDS** – 100 RPM to the maximum shown in the performance curves. For longer pump life, operate at lowest possible speeds. Lower speeds are required for viscous liquids. Consult the factory for proper speeds and horsepower requirements.
3. **SELF-PRIMING** – Primes at low or high speeds. For vertical dry suction lift of 10 feet, a minimum of 800 RPM is required. Pump will produce suction lift up to 22 feet when wet.
BE SURE SUCTION LINES ARE AIRTIGHT OR PUMP WILL NOT SELF-PRIME.
4. **DISCHARGE** – When transferring liquids further than 25', use one size larger discharge line than discharge port size.
5. **RUNNING DRY** – Unit depends on liquid pumped for lubrication. **DO NOT RUN DRY** for more than 30 seconds. Lack of liquid will damage the impeller.
6. **CHEMICAL COMPATIBILITY** – Consult the Chemical Resistance Guide in the JABSCO Industrial Pump Catalog (available upon request from ITT Jabsco) or factory for proper body materials and impeller compounds. If corrosive fluids are handled, pump life will be prolonged if pump is flushed with a neutralizing solution after each use or after each work day. A Tungsten Carbide Seal variation is available for pumping liquids that contain abrasives or are highly corrosive.
7. **PRESSURES** – Consult Performance Curve for maximum recommended pressure for pumps in continuous operation. If pressures exceed those shown, consult the factory.
8. **TEMPERATURES** – The operating temperature limits of the pump depends on the impeller compound. The following ranges apply: Neoprene - 45° to 180° F (7° to 82° C), Nitrile - 50° to 180° F (10° to 82° C), Viton - 60° to 180° F (15° to 82° C).
9. **IMPELLER TORQUE** – The torque required to initiate rotation of a new impeller in a dry pump body is:
Standard Pressure Impeller (14282-Series):
Forward = 4.8 pounds force - feet
Reverse = 11.2 pounds force - feet
These values may vary slightly due to impeller compounding, blade set, and body material of construction. Consult factory for more information.
10. **SPARE PARTS** – To avoid costly shutdowns, keep a spare JABSCO impeller, seal and O-ring set on hand.

SERVICE INSTRUCTIONS

DISASSEMBLY

1. Remove the four end cover screws. Remove end cover and O-ring.
2. Remove the four screws holding the body to the adapter flange. Slide body, complete with impeller, from adapter and shaft.
3. Remove mechanical seal by inserting two screwdrivers behind seal collar, and gently lever collar and seal assembly forward on shaft. Use extreme care not to mar shaft surface. Remove seal seat and rubber cup.
4. Remove the four screws holding the adapter to the motor and remove the adapter.
5. The stub shaft is held in place with set screws and Loctite® RC/680 retaining compound. Extreme care must be taken not to damage the motor shaft and bearings when removing the stub shaft. Heat shaft joint area to facilitate disassembly of set screws and stub shaft from motor shaft. **DO NOT EXCEED 300°F** when heating joint area. Once joint area has been heated, remove set screws and slide stub shaft from motor shaft.

ASSEMBLY

1. Liberally apply Loctite RC/680 retaining compound to the motor shaft and slide the stub shaft on, positioning the base of the stub shaft 0.37" from the bolt mounting surface of motor. For clarification, refer to Figure 1 below. Apply Loctite to the four set screws and torque to 85 - 90 in. lbs. Wipe off excess Loctite.
 2. Replace the adapter on the motor and tighten the four mounting screws to 20 ft. lbs.
 3. Replace mechanical seal by sliding spacer onto shaft up to locating shoulder, then smear shaft with light lubricating oil. Push on seal gently until it engages with spacer. Fit rubber cup and seal seat into rear of pump body.
 4. Insert impeller in pump body, fit O-ring in each end of the pump body.
 5. Slide body assembly over shaft. Fit body to adapter screws. Torque screws to 30 in. lbs.
- NOTE: Do not overtighten screws. Cracking of body may occur.
6. Fit end cover and end cover screws. Torque screws to 30 in. lbs.
 7. Changing Pump Rotation (looking at end cover):
 - a. Clockwise Rotation: Insert impeller into pump body with blades bending counterclockwise.
 - b. Counterclockwise Rotation: Insert impeller into pump body with blades bending clockwise.

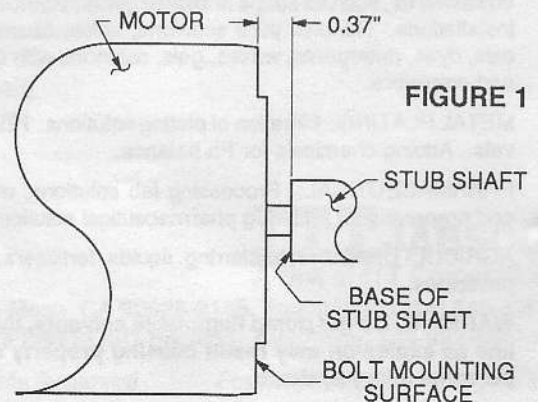

PART LIST

KEY	DESCRIPTION	QTY. REQ.	MODEL 30520-5XXX PART NO.	QTY. REQ.	MODEL 30520-3XXX PART NO.
1	Adapter	1	18753-0216	1	18753-0216
2	Body	1	18753-0190	1	18753-0190
3	End Cover	1	18753-0196	1	18753-0196
4	Shaft	1	18753-0212	1	18753-0212
5	Impeller: Standard Pressure - Neoprene Standard Pressure - Nitrile Standard Pressure - Viton	1	14282-0001 14282-0003 14282-0004	1	14282-0001 14282-0003 14282-0004
6	Motor, 2 H.P., 230Vac, 1Ph, 60Hz, TEFC, C-Face, 145 TC Frame	1	18753-0339	-	-
7	Spacer: Carbon or Tungsten Carbide	1	18753-0227	1	18753-0227
8	Seal Seat: Nitrile Viton	1	18753-0235 18753-0236	1	18753-0235 18753-0236
9	Seal Mech.: Carbon - Nitrile Carbon - Viton Tungsten Carbide - Nitrile Tungsten Carbide - Viton	1	18753-0245 18753-0246 18753-0247 18753-0248	1	18753-0245 18753-0246 18753-0247 18753-0248
10	O-Ring: Nitrile Viton	2	18753-0263 18753-0264	2	18753-0263 18753-0264
11	Screw Kit: consists of Screws, Hex Hd. 3/8-16 x 1" (4) Screws, Hex Hd. M5 x 16mm (4) Screws, Pan Hd. M5 x 8mm (4) Set Screw, Cup Pt. 1/4-20 x 3/8 (2) Set Screw, Dog Pt. 1/4-20 x 3/8 (2) Washers, Flat 3/8 (4) Washers, Flat M5 (4)	1	18753-0284	1	18753-0284

EXPLODED VIEW

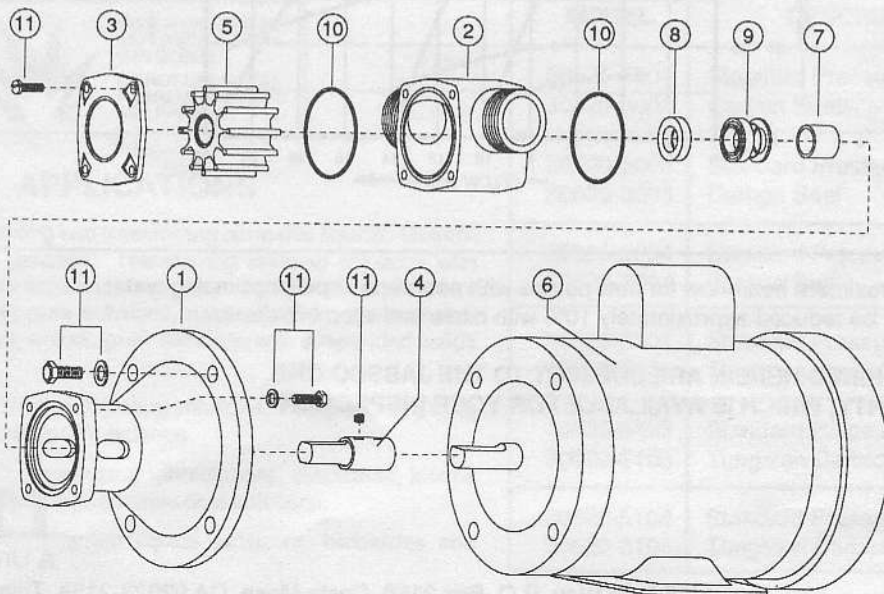

DIMENSIONAL DRAWINGS INCHES (Millimetres)

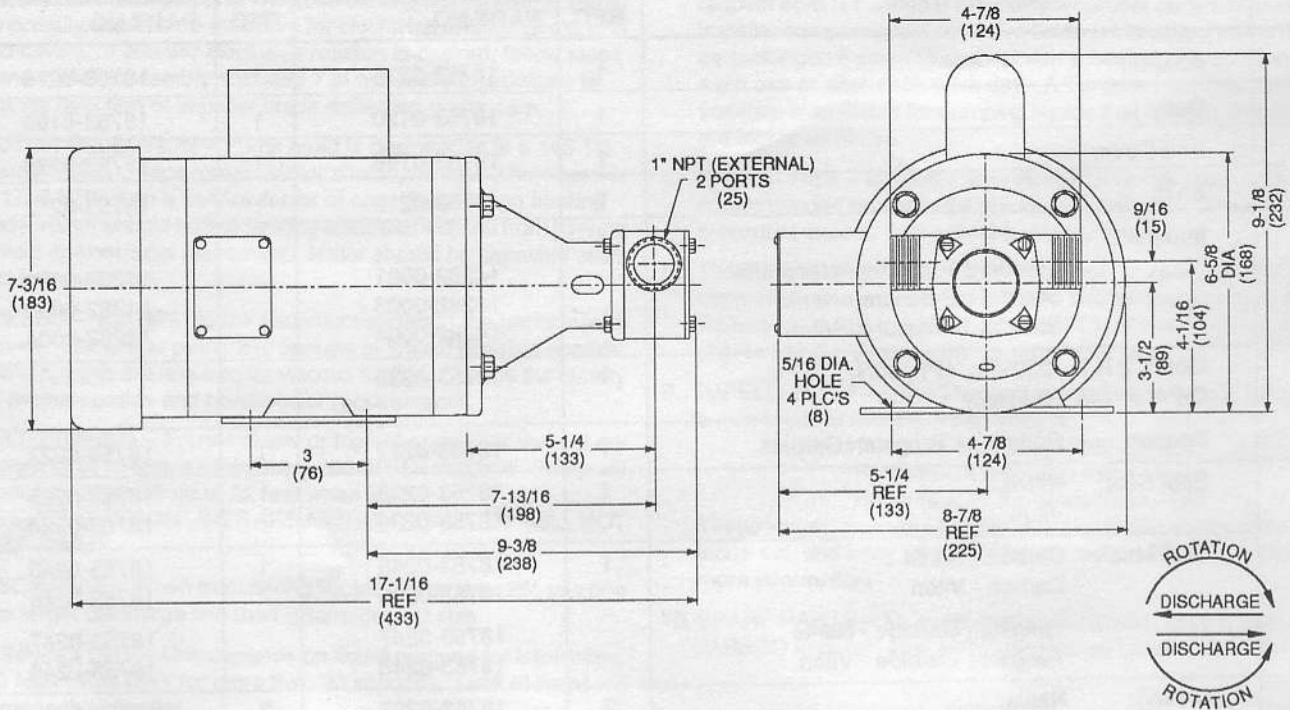

PERFORMANCE CURVES

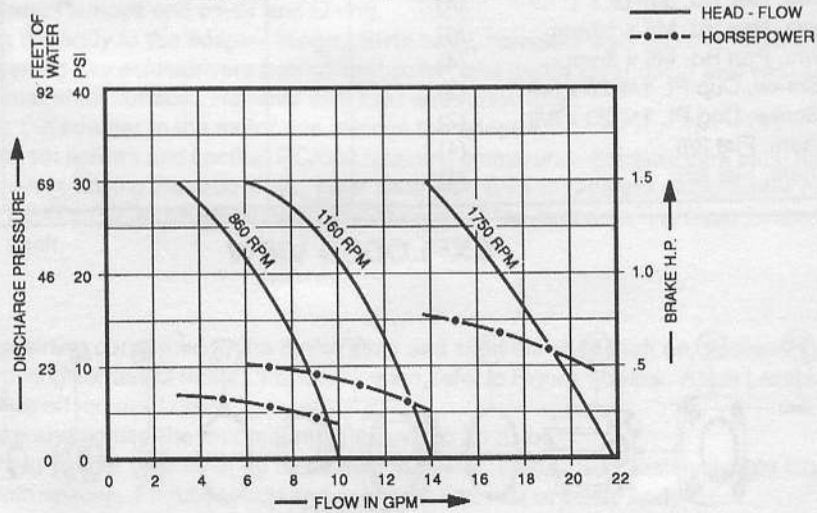

NOTE: Curve shows approximate head-flow for new pumps with neoprene impeller pumping water.
Capacities should be reduced approximately 10% with nitrile and viton impellers.

THIS PRODUCTS DESCRIBED HEREIN ARE SUBJECT TO THE JABSCO ONE YEAR LIMITED WARRANTY, WHICH IS AVAILABLE FOR YOUR INSPECTION UPON REQUEST.

ITT JABSCO
A Unit of ITT Corporation

1485 Dale Way, P.O. Box 2158, Costa Mesa, CA 92628-2158, Telephone: (714) 545-8251
Bingley Road, Hoddesdon, Hertfordshire EN11 0BU England, Telephone: +44-992-467191