

PARTS LIST			MEDIUM PRESSURE IMPELLER			HIGH PRESSURE IMPELLER		
			Neoprene Elast:	Nitrile Elast:	Viton Elast:	Neoprene Elast:	Nitrile Elast:	Viton Elast:
Key	Description	Qty	28430-2115	28430-2113	28430-2114	28430-2125	28430-2123	28430-2124
1	Screw	4	X3001-205F	X3001-205F	X3001-205F	X3001-205F	X3001-205F	X3001-205F
2	Endcover	1	28405-0010	28405-0010	28405-0010	28405-0010	28405-0010	28405-0010
3	"O" Ring	1	X4020-399A	X4020-399A	X4020-399B	X4020-399A	X4020-399A	X4020-399B
4	Impeller	1	14346-0005B	14346-0013B	14346-0014B	8983-0005B	8983-0023B	8983-0024B
5	Body	1	28434-2000	28434-2000	28434-2000	28434-2000	28434-2000	28434-2000
6	"O" Ring	1	X4020-399A	X4020-399A	X4020-399B	X4020-399A	X4020-399A	X4020-399B
7	Wearplate (2)	1	28436-0000	28436-0000	28436-0000	28436-0000	28436-0000	28436-0000
8	Seal Assy*(2)	1	28431-0103B	28431-0103B	28431-0104B	28431-0103B	28431-0103B	28431-0104B
9	Seal Spacer(1)	1	28417-0000	28417-0000	28417-0000	28417-0000	28417-0000	28417-0000
10	Lip Seal	1	SP2701-0911	SP2701-0911	SP2701-0911	SP2701-0911	SP2701-0911	SP2701-0911
11	Retaining Ring	1	SP1701-283	SP1701-283	SP1701-283	SP1701-283	SP1701-283	SP1701-283
12	Washer	4	X3080-101F	X3080-101F	X3080-101F	X3080-101F	X3080-101F	X3080-101F
13	Screw	4	X3001-209F	X3001-209F	X3001-209F	X3001-209F	X3001-209F	X3001-209F
14	Bearing Housing	1	28403-0000	28403-0000	28403-0000	28403-0000	28403-0000	28403-0000
15	Retaining Ring	1	SP1701-283	SP1701-283	SP1701-283	SP1701-283	SP1701-283	SP1701-283
16	Lip Seal	1	SP2701-0911	SP2701-0911	SP2701-0911	SP2701-0911	SP2701-0911	SP2701-0911
17	Key	1	X4000-487A	X4000-487A	X4000-487A	X4000-487A	X4000-487A	X4000-487A
18	Bearing	1	SP2601-28	SP2601-28	SP2601-28	SP2601-28	SP2601-28	SP2601-28
19	Shaft	1	28407-0000	28407-0000	28407-0000	28407-0000	28407-0000	28407-0000
20	Bearing	1	SP2601-28	SP2601-28	SP2601-28	SP2601-28	SP2601-28	SP2601-28
Service Kit Contains*			SK378-0115	SK378-0113	SK378-0114	SK378-0125	SK378-0123	SK378-0124

Other Seal Options						
Model No. With H/F Seal	28430-2215	28330-2213	28430-2214	28430-2225	28430-2223	28430-2224
Model No. With Lip Seal	28430-2415	28430-2413	Not Available	28430-2425	28430-2423	Not Available
Model No. With H/F Seal Flushed	28430-2715	28430-2713	28430-2714	28430-2725	28430-2723	28430-2724
Model No. With Standard Seal Flushed	28430-2915	28430-2913	28430-2914	28430-2925	28430-2923	28430-2924

Parts For Appropriate Seal Conversion						
8	H/F Seal Assy	1	28431-0203B	28431-0203B	28431-0204B	28431-0203B
Lip Seal Kit No. & Contains			28431-0403B	28431-0403B	Not Available	28431-0403B
21	Seal Spacer	1	28465-0011	28465-0011	Not Available	28465-0011
22	"O" Ring	1	X4020-227A	X4020-227A	Not Available	X4020-227A
23	Lip Seal	1	SP2701-0915	SP2701-0915	Not Available	SP2701-0915
24	Wearplate	1	28466-0000	28466-0000	Not Available	28466-0000
Flush Seal Kit No. & Contains			28432-0000B	28432-0000B	28432-0000B	28432-0000B
25	"O" Ring	1	X4020-261A	X4020-261A	X4020-261A	X4020-261A
26	Seal Housing	1	28412-0000	28412-0000	28412-0000	28412-0000
27	Tube	2	21844	21844	21844	21844
28	Seal Spacer	1	28417-0001	28417-0001	28417-0001	28417-0001
29	"O" Ring	1	X4020-227A	X4020-227A	X4020-227A	X4020-227A
30	Seal	1	SP2701-0915	SP2701-0915	SP2701-0915	SP2701-0915

(1) Key 9 Not Required For Models With Lip Seal And Flush Seal. (2) Key 7 & 8 Not Required For Lip Seal Models

EXPLODED VIEW

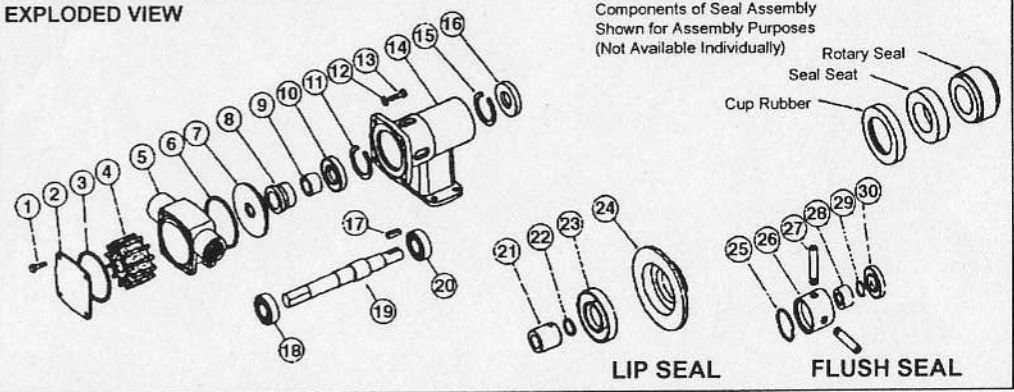

Components of Seal Assembly Shown for Assembly Purposes (Not Available Individually)

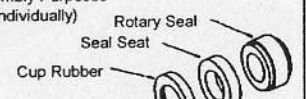

LIP SEAL FLUSH SEAL

SERVICE INSTRUCTIONS

Dis-Assembly

1. Remove screws (1), endcover and "O" ring
2. Remove screws (13). Slide off body complete with impeller and wearplate.
3. Remove seal seat, cup rubber from the wearplate and push out impeller and "O" ring from body.
4. Gently lever the seal spacer and seal (8) off the shaft.
5. Prise out seal (16). Remove retaining ring (15) and carefully withdraw shaft and bearing assembly. Remove retaining ring (11) and push out seal (10).
6. To remove bearings from shaft an arbor press is required alternatively a bearing extractor may be used. Support inner race of bearing then apply a steady pressure on shaft until bearing is free. Repeat this procedure to remove other bearing.

PUMPS WITH LIP SEAL:- Push out lip seal (23) from wearplate (24). Loosen set screw to remove seal spacer (21). Prise out "O" ring (22) from seal spacer.

PUMPS WITH FLUSH SEAL:- After pulling out rotary seal, unscrew tubes (27) and pull out seal housing (26). Remove seal spacer (28) and prise out "O" ring (29). Remove "O" ring (25) and lip seal (30) from seal housing.

Assembly

1. To fit bearings onto shaft:- Support inner race of bearing and press the shaft until bearing locates against the shoulder. Repeat procedure for other bearing.
 2. Fit retaining ring (11) and lip seal (10) ensuring that spring on seal is facing outwards.
 3. Fill the bearings with grease, and the space between bearings two thirds full. Smear grease on the shaft where lip seal locates. Push shaft and bearing assembly into bearing housing. Fit retaining ring (15) and seal (16) with spring facing outwards.
 4. To fit seal:- Smear shaft with lubricating oil and slide seal spacer (19) up to the shoulder on shaft. Push rotary seal gently until it touches the spacer. Fit cup rubber and seal seat into wearplate (7). Slide wearplate assembly over the shaft.
 5. Fit impeller into lubricated body with twisting motion in the same rotation as motor. Fit "O" ring (6) into body and slide over shaft.
 6. Align wearplate and body into bearing housing and secure with screws (13) and washers (12). Do Not overtighten, a gap between bearing housing and body is normal. These screws and endcover screws should be tightened to a torque of 6.8 Nm.
 7. Fit "O" ring (3) into body and place endcover over body and secure with screws (1). **PUMPS WITH LIP SEAL:-** Ensure "O" ring (22) is fitted under seal spacer (21). Smear seal spacer and shaft with lubricating oil. Slide spacer over shaft and secure with set screw to dimension shown. Press lip seal (23) into wearplate (24) and follow on from step 5 above.
- PUMPS WITH FLUSH SEAL:-** Ensure "O" ring (29) is fitted under seal spacer (28). Smear seal spacer and shaft with lubricating oil. Slide spacer over shaft up to shoulder. Press lip seal (30) into seal housing (26) and slide into position over shaft. Fit tubes (27) sealing with PTFE tape. Rotary seal and "O" ring (25) can now be fitted Follow on from step (5) above.
- Inspect all parts for wear or damage and replace if necessary.**

INSTALLATION DRAWING

