

Jabscó 28350 SERIES

EXPLODED VIEW

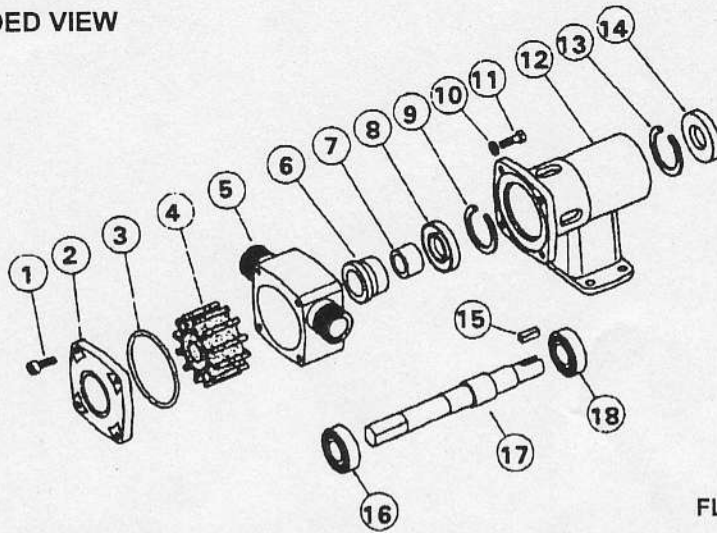

Components of Seal Assembly Shown for Assembly Purposes (Not Available Individually)

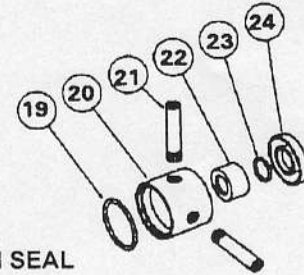
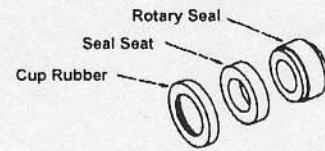

FLUSH SEAL

PARTS LIST			STANDARD PRESSURE IMPELLER			HIGH PRESSURE IMPELLER		
Key	Description	Qty	Neoprene Elast: 28350-2101	Nitrile Elast: 28350-2103	Viton Elast: 28350-2104	Neoprene Elast: 28350-2121	Nitrile Elast: 28350-2123	Viton Elast: 28350-2124
1	Endcover Screw	4	X3002-182F	X3002-182F	X3002-182F	X3002-182F	X3002-182F	X3002-1823F
2	Endcover	1	28355-0000	28355-0000	28355-0000	28355-0000	28355-0000	28355-0000
3	"O" Ring*	1	X4020-269A	X4020-269A	X4020-269B	X4020-269A	X4020-269A	X4020-269B
4	Impeller*	1	14282-0001B	14282-0003B	14282-0004B	8840-0021B	8840-0023B	8840-0024B
5	Body	1	28354-2000	28354-2000	28354-2000	28354-2000	28354-2000	28354-2000
6	Seal Assembly*	1	28331-0103B	28331-0103B	28331-0104B	28331-0103B	28331-0103B	28331-0104B
7	Seal Spacer(1)	1	28317-0000	28317-0000	28317-0000	28317-0000	28317-0000	28317-0000
8	Lip Seal	1	SP2700-0910	SP2700-0910	SP2700-0910	SP2700-0910	SP2700-0910	SP2700-0910
9	Retaining Ring	1	SP1701-438	SP1701-438	SP1701-438	SP1701-438	SP1701-438	SP1701-438
10	Washer	4	X3080-091F	X3080-091F	X3080-091F	X3080-091F	X3080-091F	X3080-091F
11	Screw	4	X3001-182F	X3001-182F	X3001-182F	X3001-182F	X3001-182F	X3001-182F
12	Bearing Housing	1	28303-0000	28303-0000	28303-0000	28303-0000	28303-0000	28303-0000
13	Retaining Ring	1	SP1701-438	SP1701-438	SP1701-438	SP1701-438	SP1701-438	SP1701-438
14	Lip Seal	1	SP2700-0910	SP2700-0910	SP2700-0910	SP2700-0910	SP2700-0910	SP2700-0910
15	Key	1	X4000-130A	X4000-130A	X4000-130A	X4000-130A	X4000-130A	X4000-130A
16	Bearing	1	SP2601-33	SP2601-33	SP2601-33	SP2601-33	SP2601-33	SP2601-33
17	Shaft	1	28357-0000	28357-0000	28357-0000	28357-0000	28357-0000	28357-0000
18	Bearing	1	SP2601-33	SP2601-33	SP2601-33	SP2601-33	SP2601-33	SP2601-33
Service Kit Contains*			SK377-0101	SK377-0103	SK377-0104	SK377-0121	SK377-0123	SK377-0124

OTHER SEAL OPTIONS

Model No. with H/F Seal	28350-2201	28350-2203	28350-2204	28350-2221	28350-2223	28350-2224
Model No. with Std. Seal Flushed	28350-2901	28350-2903	28350-2904	28350-2921	28350-2923	28350-2924
Model No. with H/F Seal Flushed	28350-2701	28350-2703	28350-2704	28350-2721	28350-2723	28350-2724

PARTS FOR APPROPRIATE SEAL CONVERSION

6 Seal Assy H/F	1	28331-0203B	28331-0203B	28331-0204B	28331-0203B	28331-0203B	28331-0204B
Flushed Seal Kit No. & Contains		28332-0000B	28332-0000B	28332-0000B	28332-0000B	28332-0000B	28332-0000B
19 "O" Ring	1	X4020-244A	X4020-244A	X4020-244A	X4020-244A	X4020-244A	X4020-244A
20 Seal Housing	1	28312-0000	28312-0000	28312-0000	28312-0000	28312-0000	28312-0000
21 Tube	2	21844	21844	21844	21844	21844	21844
22 Seal Spacer	1	28317-0001	28317-0001	28317-0001	28317-0001	28317-0001	28317-0001
23 "O" Ring	1	X4020-217A	X4020-217A	X4020-217A	X4020-217A	X4020-217A	X4020-217A
24 Lip Seal	1	SP2701-0914	SP2701-0914	SP2701-0914	SP2701-0914	SP2701-0914	SP2701-0914

(1) Item 7 Not Required if Flush Seal Fitted.

INSTALLATION DRAWING

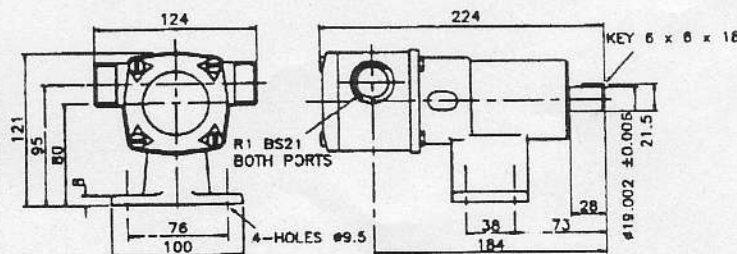

SERVICE INSTRUCTIONS

Dis-Assembly

1. Remove screws (1), endcover and "O" ring. Remove screws (11) and slide off body complete with impeller.
2. Remove seal seat, cup rubber and push out impeller from body.
3. Gently lever the seal spacer and seal (6) off the shaft.
4. Prise out seal (14). Remove retaining ring (13) and carefully withdraw shaft with bearings assembled. Remove retaining ring (9) and push out seal (8).
5. To remove bearings from shaft an arbor press is required, alternatively a bearing extractor may be used:- "Support inner race of ball bearing, then apply a steady pressure on shaft until bearing is free. Repeat procedure to remove other bearing".

Note: Pumps with Flush Seal

After pulling out mechanical seal (6), unscrew tubes (21) and pull out seal housing.

Remove seal spacer. Remove "O" ring (23) and lip seal (24) from seal housing if necessary.

Assembly

1. To fit bearings onto shaft:- Support inner race of bearing and press the shaft until bearing locates against the shoulder. Repeat procedure for other bearing.
2. Fit retaining ring (9) and lip seal (8) ensuring that spring on seal is facing outwards.
3. Fill the bearings with grease, and the space between bearings two thirds full. Smear grease on the shaft where lip seal locates. Push shaft and bearing assembly into bearing housing. Fit retaining ring (13) and seal (14) with spring facing outwards.
4. To fit seal:- Smear shaft with lubricating oil and slide seal spacer up to the shoulder on shaft. Push rotary seal gently until it touches the spacer. Fit impeller into lubricated body with a twisting motion in the same direction as motor, then cup rubber and seal seat. Slide this assembly over shaft and fit screws (10) washers (11). Fit "O" ring into endcover and secure with screws onto body.

Note: Pumps with Flush Seal

Ensure "O" ring (23) is fitted under seal spacer (22).

Smear seal spacer with lubricating oil. Press lip seal (24) in seal housing (20) and slide into position. Fit tubes (21) sealing with PTFE tape. Rotary seal and the "O" ring (19) can now be fitted.

Inspect all parts for wear or damage and replace if necessary.