

# Jabsco 22840: 22841 SERIES

## EXPLODED VIEW

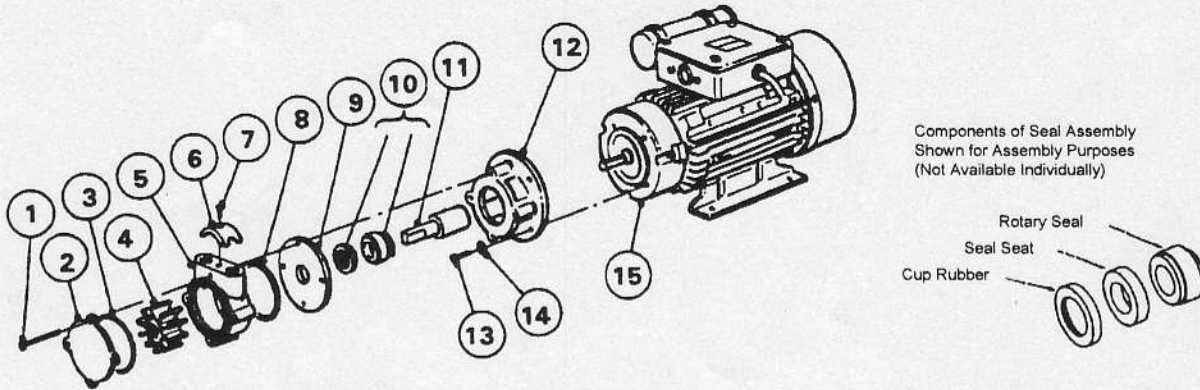

Components of Seal Assembly  
Shown for Assembly Purposes  
(Not Available Individually)

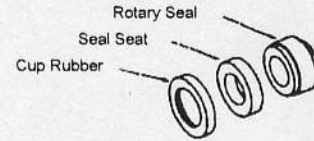

PARTS LIST			HIGH PRESSURE IMPELLER		
			Neoprene Elast:	Nitrile Elast:	Viton Elast:
Key	Description	Qty	22841-2121	22841-2123	22841-2124
1	Screw	4	SP1093-01	SP1093-01	SP1093-01
2	Endcover	1	10106	10106	10106
3	"O" Ring	1	SP2000-41	SP2000-41	SP2000-77
4	Impeller*	1	14874-0021B	14874-0023B	14874-0024B
5	Body	1	864-200	864-200	864-200
6	Cam	1	900	900	900
7	Cam Screw	1	SP1041-01	SP1041-01	SP1041-01
8	"O" Ring	1	SP2000-41	SP2000-41	SP2000-77
9	Wearplate	1	22844-0001	22844-0001	22844-0001
10	Seal Assembly*	1	SP6080-28B	SP6080-28B	SP6080-29B
11	Drive Sleeve	1	23068-0000	23068-0000	23068-0000
12	Adaptor	1	21494	21494	21494
13	Screw	4	X3001-180C	X3001-180C	X3001-180C
14	Washer	4	X3081-091C	X3081-091C	X3081-091C
15	Motor	1	SP8012-0199	SP8012-0199	SP8012-0199
Service Kit Contains*			SK176	SK176-37	SK176-59
Model 22840 As Above Except Key 15			22840-2121	22840-2123	22840-2124

## SERVICE INSTRUCTIONS

### Dis-Assembly

1. Remove screws (1), and slide out body assembly from motor adaptor.
  2. Separate endcover, "O" rings and push out impeller.
  3. If necessary remove cam screw (7) and cam from body. Clean off sealant from all surfaces.
  4. Remove wearplate and then prise out seal seat and cup rubber.
  5. Gently lever the rotary seal off the drive sleeve. Do not exert excessive axial or radial pressure on sleeve.
- Removal of the following parts is not necessary for normal servicing. However, if required proceed as follows:- Remove screws (13) and washers (14) and slide off adaptor (12).

6. Apply heat and leverage slide off drive sleeve. Do not heat damage motor seal and bearing.

### Assembly

1. Bonding of drive sleeve 23068-0000 to motor shaft. Ensure surfaces are clean, free of any grease, and dry. Apply a thin coat of epoxy resin adhesive (twin pack) to both surfaces. Slide drive sleeve onto shaft to dimension shown. Remove excess adhesive. Allow to cure as per adhesive instructions.
2. Smear shaft with lubricating oil and push rotary seal gently until it touches the shoulder of the drive sleeve.
3. Fit adaptor (12) to motor face with screws (13) and washers (14).
4. Fit cup rubber and seal seat into wearplate (9) and slide it into position.
5. Apply a thin coat of sealant to screw threads (7), top and back face of cam (6) and then fit into body keeping the faces flush.
6. Push impeller into lubricated body with a twisting motion in the same rotation as the motor. Fit "O" rings into body groove.
7. Align holes of wearplate, body assembly and endcover with adaptor securing these parts with screws (1).

Inspect all parts for wear or damage and replace if necessary.

### Spare Parts For The Old Model 22840-2011

Key 9 Wearplate 22844-0000  
Key 10 Seal Assbly 28331-0103B  
Key 11 Shaft Ext: 22847-0000  
Other Parts As Shown in Table

## INSTALLATION DRAWING 22841

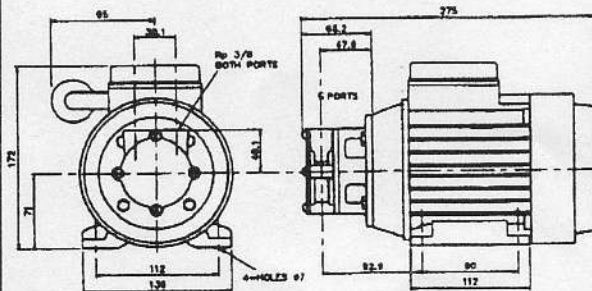

Suitable For Up to 1.5 Bar Differential Pressure

## HEAD KIT 22840

Suitable for (a) 71-B3/B14 Motor Frame To IEC Standard  
(b) Differential Pressure 1.5 Bar

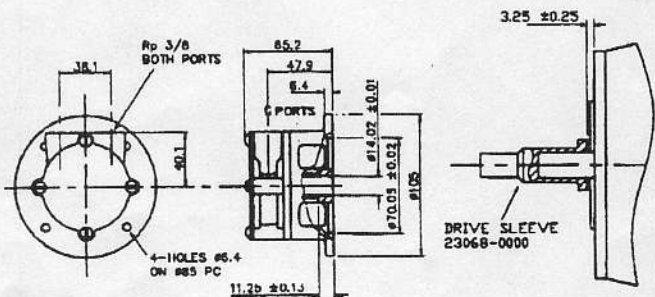

Bonding Dimension