

Jabscoc 22760 SERIES

EXPLODED VIEW

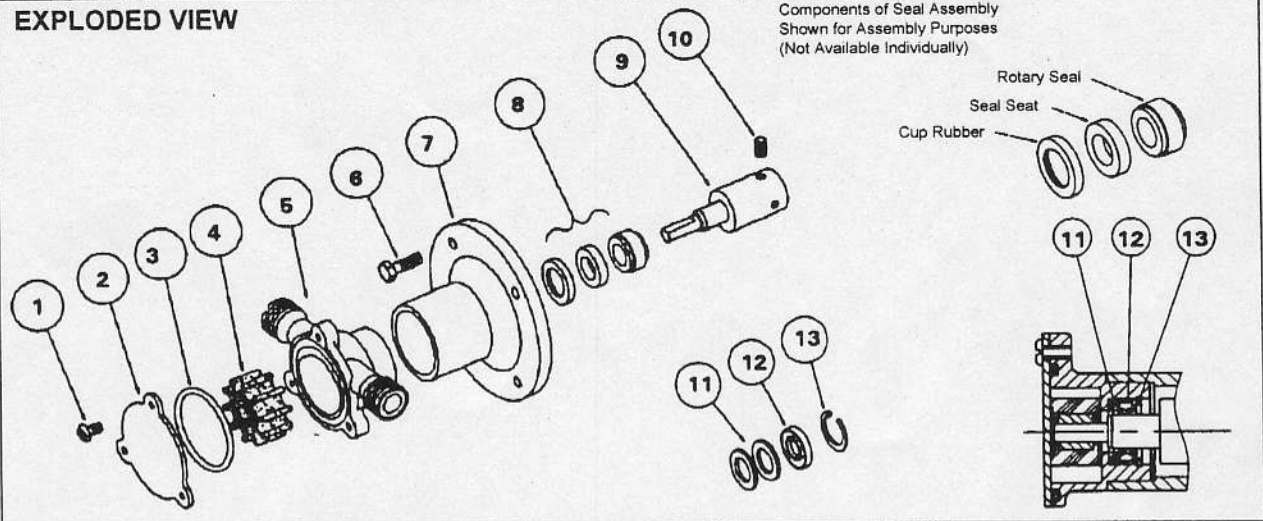

Components of Seal Assembly
Shown for Assembly Purposes
(Not Available Individually)

PARTS LIST			MEDIUM PRESSURE IMPELLER		(2) HIGH PRESSURE IMPELLER	HIGH TEMPERATURE IMPELLER
			Neoprene Elast:	Nitrile Elast:	Nitrile Elast:	3A Neoprene Elast:
Key	Description	Qty	22760-2111	22760-2113	22760-2123	22760-2165
1	Screw*	3	X3002-151F	X3002-151F	X3002-151F	X3002-151F
2	Endcover	1	11154-0020	11154-0020	11154-0020	11154-0020
3	"O" Ring*	1	SP2000-58	SP2000-58	SP2000-58	SP2000-58
4	Impeller*	1	9200-0011B	9200-0013B	14048-0023B	23250-0065B
5	Body(1)	1	22174-2100	22174-2100	22174-2100	22174-2100
6	Screw	4	X3001-180C	X3001-180C	X3001-180C	X3001-180C
7	Adaptor(1)	1	22764	22764	22764	22764
8	Seal Assembly*	1	SP8021-0301B	SP8021-0301B	SP8021-0301B	SP8021-0301B
9	Shaft Extension	1	22767	22767	22767	22767
10	Set Screw	2	X3009-176A	X3009-176A	X3009-176A	X3009-176A
Service Kit Contains*			SK320-02	SK320-0113	SK320-0123	SK320-0115T
Lip Seal Model No. & Contains			22760-2411	22760-2413	22760-2423	22760-2465
5	Body(1)	1	11234-2020	11234-2020	11234-2020	11234-2020
9	Shaft Extension	1	22777-0000	22777-0000	22777-0000	22777-0000
11	Spacer	2	11146	11146	11146	11146
12	Seal	1	SP2701-19	SP2701-19	SP2701-19	SP2701-19
13	Retaining Ring	1	SP1700-1000	SP1700-1000	SP1700-1000	SP1700-1000
Note: Lip Seal Models Have Different Body & Shaft Extension						
(1) Body & Adaptor Not Available Separately. (2) Model Now Obsolete						

SERVICE INSTRUCTIONS

Dis-Assembly

1. Remove screws (1), endcover, "O" ring and withdraw impeller from body.
2. Remove screws (6) and withdraw body and adaptor assembly from motor.
3. Remove rotary seal from shaft end, seal seat and cup rubber from body. Removal of the following parts is not necessary for normal servicing. However, if required proceed as follows:-
4. To remove shaft extension loosen set screws (10), then applying heat and leverage slide off shaft extension. Do not heat damage motor seal and bearing.
5. Body and adaptor can not be separated without special tools and instructions.

Do not tamper with motor.

Pumps with lip seal:- After step 2 above, remove retaining ring (13) from body and push out spacers (11) and seal (12).

Assembly

1. To fit shaft extension:- Clean shaft extension and motor shaft thoroughly and dry. Use a few drops of "loctite 241" adhesive on both surfaces and press on shoulder of shaft extension whilst supporting motor shaft (fan end). Remove excess adhesive. Tighten set screws (10). Do not damage seal area and motor bearings.
2. Smear shaft with lubricating oil, slide shim, and rotary seal (spring motor end) gently until it touches shaft shoulder.
3. Fit cup rubber and seal seat into body.
4. Fit motor and adaptor assembly to motor face with screws (6) ensuring the drain slot is at the bottom.
5. Push impeller into lubricated body with a twisting motion in the same direction as motor.
6. Place "O" ring and endcover over body and secure with screws (1).

Pumps with lip seal:- After step 2 slide seal spacers (11) into body. (Note: If the shaft is badly worn by the lip seal, one of the spacers (11) may be re-positioned to give the lip seal another sealing location) and press the lip seal in and secure with retaining ring (13).

Inspect all parts for wear or damage and replace if necessary.

INSTALLATION DRAWING

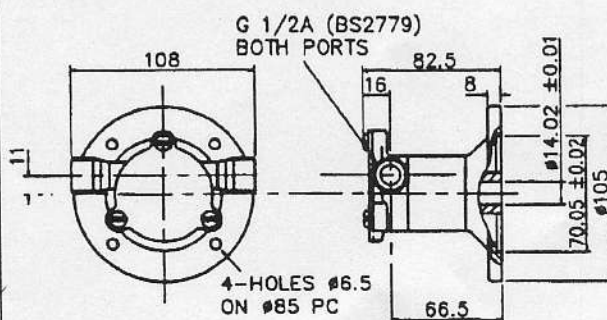

Suitable For : 71 B3/B14 Motor To IEC Standard
: Up to 1.5 Bar Differential Pressure