

[Home](#)[Up](#)[Contents](#)[Index](#)[Jabsco Search](#)[Databases](#)

# 22040 Info



## 22040 General Information

PORT SIZE	PORT TYPE	MATERIAL	SIZE	MOUNTING	BRG TYPE	SEAL TYPE
2"	Flange	Bronze	270	Flange	Ball	Mechanical

### History

### Other

-01 & -0131 have a right hand thread on the drive end of the shaft.

-0501 & -0531 have a left hand thread.

### OEM

Standard on M.A.N engines. Left hand & right hand rotation probably reflects 'handed' engine option for twin engine craft.

### Known Variants

Model	Detail
22040-01	full cam, different body to others
22040-0131	high flow cam
22040-0501	full cam, shaft variation
22040-0531	high flow cam, shaft variation

[Home](#)[Up](#)[Contents](#)[Index](#)[Jabco Search](#)[Databases](#)

# 22040 Parts



## 22040 Exploded View & Parts List

Parts List					Service Kit
Key	Description	Model	Qty	Part No.	Pump Model
1	End Cover Screw	All	5	SP1005-04	All Models
2	End Cover	All	1	9336	Same as SK254
3	Gasket	All	1	816	
4	Cam	All -except	1	6988	
		-0131 & 0531	1	22039	
5	Cam Screw	All -except	1	SP1005-04	Each kit comprises
		-1541	1	SP1005-05	Impeller
6	Spline Seal	All	1	4346	Seal
7	Impeller	All	1	17936-0001	Gasket
9	Body	All -except	1	11104-03	End Cover Screws
		-01	1	11104-02	
	Plug	All	2	SP2650-0226	
10	Wearplate	All	1	2574	
11	Seal	All	1	21849	
18	Slinger	All	1	3181-0000	
19	Bearing Housing	All	1	22044	
20	Bearing Seal	All	1	SP2700-50	
21	Bearing	All	1	SP2601-32	
24	Retaining Ring	All	1	SP1700-283	
25	Shaft	-01, -0131	1	21239	
		-0501, 0531	1	21239-0010	
28	Key	All	1	SP1402-23	
29	Washer	All	1	23018-0000	
30	Nut	All	1	23016-0000	
36	Bolt	All	4	SP1095-28	
37	Washer	All	4	SP1602-13	

Spline seal supplied with impeller.

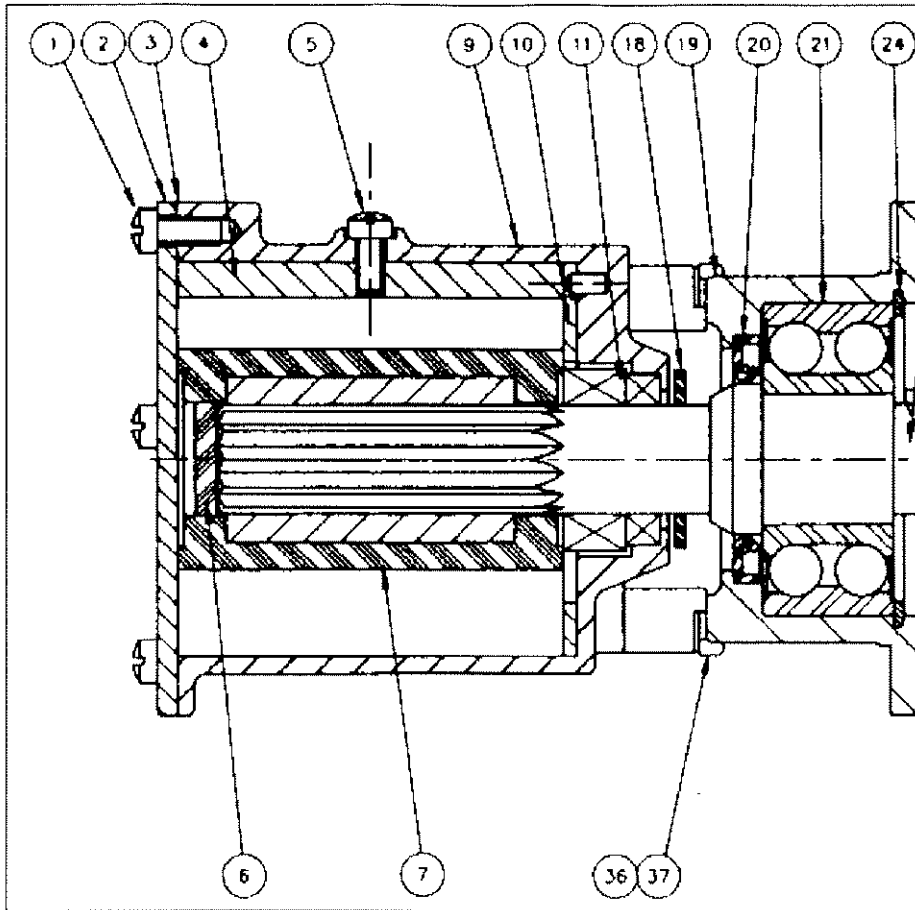

2240-SERIES  
PARTS LIST

1974 August 1974  
1974 September 1974

1974 1974