

JABSCO

Model 18630-SERIES

Model 18630-SERIES

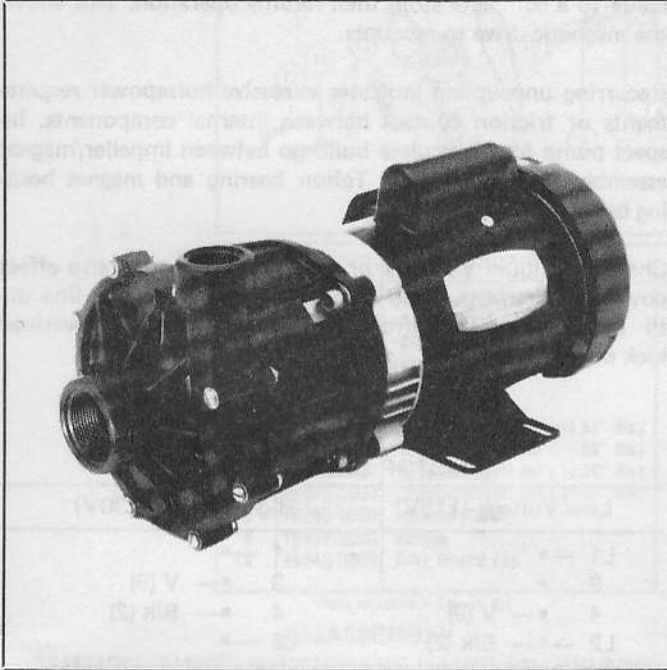

Seal-less Magnetic Drive Centrifugal Pumps

FEATURES

Pump Material: Glass-filled epoxy plastic suitable for temperatures to 200° F (93°C)

Impeller Design: Enclosed 4.50" Dia. - 1 ½ hp
4.35" Dia. - 1 hp
4.00" Dia. - ¾ hp
3.50" Dia. - ½ hp

Magnetic Drive: Magnets enclosed in a molded epoxy cup. Minimum decoupling torque is 40 in. lbs.

Ports: Suction 1 ½" NPT Internal
Discharge 1" NPT Internal

Motors: Totally enclosed fan cooled, NEMA 56J C-face, 115/230 Vac, Single Phase, 60 Hz, 3450 RPM, Ball Bearing, Class B Insulation, Thermal Overload Protected.

Weight:

1 ½ hp TEFC	41.5 lbs (18,8 kgs)
1 hp TEFC	34.5 lbs (15,6 kgs)
¾ hp TEFC	34.5 lbs (15,6 kgs)
½ hp TEFC	31.5 lbs (14,3 kgs)

⚠ MOTOR WARNING



MOTOR CAN SPARK
EXPLOSION & DEATH
CAN OCCUR

DO NOT USE WHERE
FLAMMABLE VAPORS
ARE PRESENT

STANDARD MODELS

IMPELLER SIZE	MOTOR HP	MOTOR PUMP UNIT
4.50" Dia.	1 ½	18630-0007
4.35" Dia.	1	18630-0001
4.00" Dia.	¾	18630-0003
3.50" Dia.	½	18630-0005

APPLICATIONS

Seal-less magnetic drive centrifugal motor pump units are designed to handle corrosive liquids without concern for selection of exotic mechanical shaft seal materials or leakage of expensive or dangerous fluids between shaft and housing.

Highly corrosive chemicals or caustic solutions compatible with glass-filled epoxy plastic may be transferred or circulated. All parts in contact with fluid are glass-filled epoxy plastic, Ryton*, ceramic or graphite filled Teflon*. A Viton* O-ring gasket is also used.

Chemicals such as alcohols, benzene, hexane, chlorinated hydrocarbons, ether compounds, fatty acids, hydrochloric acid, phosphoric acid, tannic acid, carbolic acid, sodium hydroxide, sodium nitrate, potassium hydroxide, ammonium hydroxide, toluene, trichloroethylene, lacquers, etc., may be

handled. For a more complete list of liquids compatible with epoxy plastic, consult the Jabsco Chemical Resistance Table (available upon request from ITT Jabsco) or contact the factory.

Typical applications include transfer, circulation or filtration of photo chemicals, etching solutions, plating baths, laboratory systems, processing, transfer and application of agricultural chemicals, fume scrubbing, circulation, and exotic metal recovery processes.

WARNING: THE TEFC MOTOR IS NOT SUITABLE FOR ENVIRONMENTS WHERE FLAMMABLE VAPORS ARE PRESENT. IF USED, EXPLOSION MAY RESULT.

Ryton* is a trademark of Phillips Petroleum Company.

Teflon* and Viton* are trademarks of E. I. Du Pont de Nemours and Company.

INSTALLATION

LOCATION — Pumps with TEFC motors must be mounted in the horizontal position. Volute body may be removed and rotated to any one of eight different port positions to simplify piping. It is prudent, however, to install body and piping to eliminate possibility of air pockets in either the suction or discharge passages. **THIS PUMP WILL NOT SELF-PRIME!** If the pump is to be mounted above the liquid level, provisions must be made prior to starting pump to assure that the suction line and pump cavity are flooded.

To prevent cavitation and obtain maximum service life, it is important that suction line is free of restrictions and sharp bends. Factory application engineering assistance is available.

WARNING: EXCESSIVE PRESSURE MAY CAUSE PUMP HOUSING FAILURE. SEVERE PERSONAL INJURY OR DEATH MAY OCCUR. DO NOT ALLOW OUTLET PRESSURES TO EXCEED 40 psi (2,8 kg/cm²).

PLUMBING — All piping to the pump must be supported independent of the pump. Keep suction and discharge piping as free of elbows and bends as possible. To assure optimum performance, piping to suction port should be the same size as suction port and be straight for a minimum length of 12" without elbows or reducers.

NOTICE: Use only plastic fittings in the suction and discharge ports. Use Teflon tape or Loctite PST* pipe sealant to seal threads. Do not overtighten. Damage to pump may result if disregarded.

Suction line must be airtight to maintain prime. A flap type foot valve at the suction intake or a check valve in the discharge line may be installed to retain liquid in a system during shut-down. Auxiliary priming and drain lines may be installed by drilling and tapping the surfaces provided on the volute face (see dimensional drawing).

WIRING — Consult the motor wiring connection diagram below or motor label for 115 Vac or 230 Vac motor connection.

OPERATION — Pump must be primed to begin pumping operation. Do not operate pump dry.

If pumping action ceases during normal operation and the motor continues to run, uncoupling of magnetic drive has occurred. Disconnect power to the motor, let pump motor come to a complete stop, then resume operation. This allows the magnetic drive to recouple.

Recurring uncoupling indicates excessive horsepower requirements or friction contact between internal components. Inspect pump for particulate build up between impeller/magnet assembly inside diameter, Teflon bearing and magnet housing boss.

Change in liquid viscosity or specific gravity may also affect power requirement. Restrict flow through discharge line until pump operates without uncoupling or motor overload kick out occurring.

MOTOR CONNECTIONS

Low Voltage (115V)	High Voltage (230V)
L1 —•	L1 —•
3 •	3 •— V (9)
4 •— V (9)	4 •— Blk (2)
L2 —•— Blk (2)	L2 —•

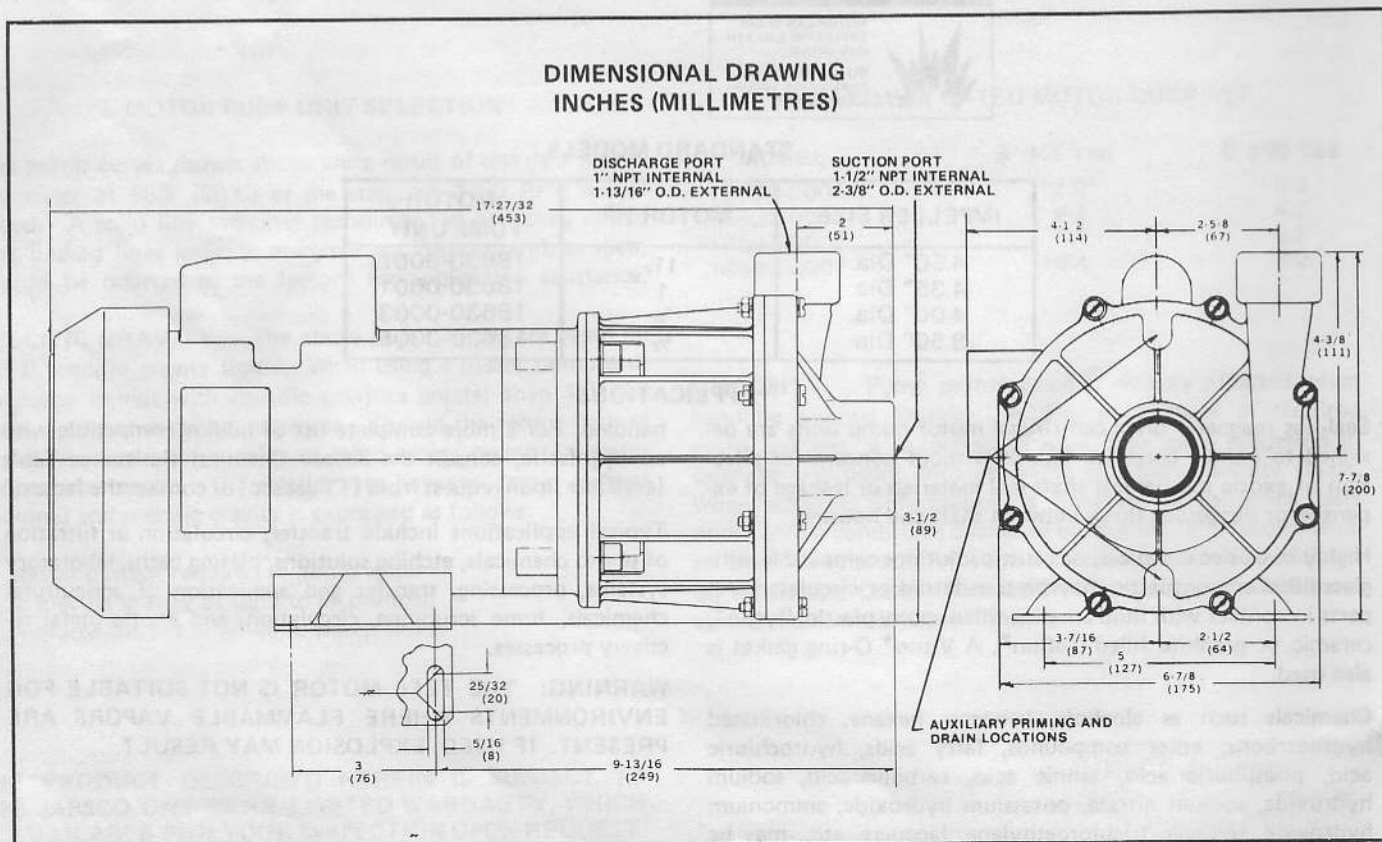

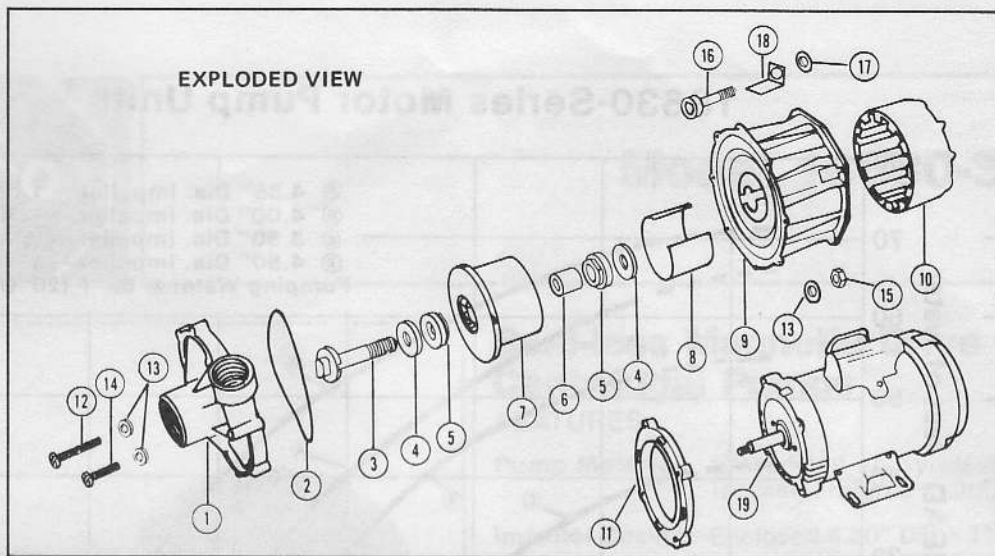

KEY	PART NO.	DESCRIPTION	QTY	KEY	PART NO.	DESCRIPTION	QTY
1	17826-0000	Volute Body	1	11	18326-0000	Adaptor	1
2	—	* O-Ring (Viton)	1	12	—	**Screw (No. 10-32 x 2)	1
3	18353-0000	* Cap Bolt (Ryton)	1	13	—	**Flat Washer (No. 10)	16
4	18363-0000	* Seat (Ceramic)	2	14	—	**Screw (No. 10-32 x 1/4)	7
5	18356-0000	* Bushing (Ryton)	2	15	—	**Hex Nut (No. 10-32)	8
6	—	* Sleeve (Ceramic)	1	16	—	**Socket Head Bolt (3/8-16 x 1 1/2)	4
7	18243-0000	Impeller/Magnet Ass'y (4.35" Dia.)	1	17	—	**Flat Washer (3/8)	4
	18243-0001	Impeller/Magnet Ass'y (4.00" Dia.)	1	18	—	**Guard	4
	18243-0002	Impeller/Magnet Ass'y (3.50" Dia.)	1	19	18753-0024	Motor 1 hp TEFC	1
	18243-0003	Impeller/Magnet Ass'y (4.50" Dia.)	1		18753-0022	Motor 3/4 hp TEFC	
8	18249-0000	* Bearing (Teflon)	1		18753-0023	Motor 1/2 hp TEFC	
9	18634-0000	Housing	1		18753-0026	Motor 1 1/2 hp TEFC	
10	18246-0000	Drive Magnet Cup	1		18753-0030	Service Kit	
					18753-0035	Hardware Kit	

*Parts Included in Service Kit

**Parts Included in Hardware Kit

DISASSEMBLY

CAUTION: PUMPS WHICH HAVE HANDLED CORROSIVE, CAUSTIC OR TOXIC FLUIDS SHOULD BE DRAINED AND COMPLETELY FLUSHED PRIOR TO SERVICING. FAILURE TO DO SO MAY CAUSE INJURY.

- Remove eight screws, washers and nuts securing volute body to housing. Remove O-ring from groove in volute.
- Turn cap bolt, located in eye of impeller, counterclockwise to loosen and remove bolt and ceramic seat.
- Remove impeller/magnet assembly with a firm, straightaway pull. Remove two bushings from front and rear of impeller, as well as sleeve. Remove Teflon sleeve bearing from large bore of assembly. Remove ceramic seat from counterbore of housing.
- Remove four bolts, guards and washers securing housing to motor. Remove housing from adaptor. Adaptor cannot be removed from motor until drive magnet cup is removed from shaft.
- Loosen set screw in drive magnet cup. Prevent motor shaft from turning (insert screwdriver into slot in motor shaft, under cap at rear of motor). Turn drive magnet cup in a counterclockwise direction to remove. Remove adaptor.
- Clean all parts and inspect for excessive wear. Replacement of Viton O-ring is recommended when servicing pump.
- Use screwdriver to rotate shaft to check for rubbing of parts. If scuffing is detected, check position of drive magnet cup on shaft to make sure it is properly bottomed against shaft shoulder.
- Install Teflon sleeve bearing into bore in drive end of impeller. Sleeve bearing is taper cut so that, when rolled into a cylinder and properly installed in bore of impeller/magnet assembly, the edges are parallel.
- Place a small quantity of a good grade of water pump grease on one side of each ceramic seat. Install one seat into counterbore of housing, with grease side against housing. Install second seat over threaded shank of cap bolt, with grease side to back of cap. Place a small quantity of a good grade of water pump grease on the flats of the bushings and install bushings into bore of impeller/magnet assembly, front and back, fitting flats on bushings into corresponding flats in impeller/magnet assembly. Holding bushings in place, insert sleeve into bushings. Taking care not to dislodge bushings or seat, install impeller into housing. Hold impeller firmly or magnetic attraction will snap impeller into housing and dislodge bushings and seat. Place a drop of Loctite 222 on threads of housing. **Failure to apply Loctite 222 on threads in housing will cause bolt to back-out resulting in early pump failure.** Insert cap bolt through sleeve in impeller/magnet assembly. Thread into housing until seated firmly, and all seats and bushings are nested, with all flats coinciding. Torque cap bolt to 20 in.-lbs. Over-torquing cap bolt or misalignment of flats will result in a fracture of the ceramic seats and therefore require their replacement.
- Install O-ring in volute body. Position volute body against the housing and secure with machine screws, washers and nuts. Torque machine screws to 24 in.-lbs. Place washers under machine screw heads and nuts to protect plastic.

ASSEMBLY

- Install adaptor on motor face. Hold in place with one socket head cap bolt, while drive magnet cup is being assembled.
- Thread drive magnet cup onto motor shaft until it bottoms firmly against shoulder. Use screwdriver in slot under shaft cap of motor to tighten drive magnet cup on shaft.
- Tighten set screw in magnet drive cup against shaft.
- Remove socket head cap bolt holding adaptor and secure housing to motor aligning flats on housing face in vertical position with four socket head cap bolts, placing guards and flat washers under heads. Torque cap bolts to 43 in.-lbs.

18630-Series Motor Pump Units

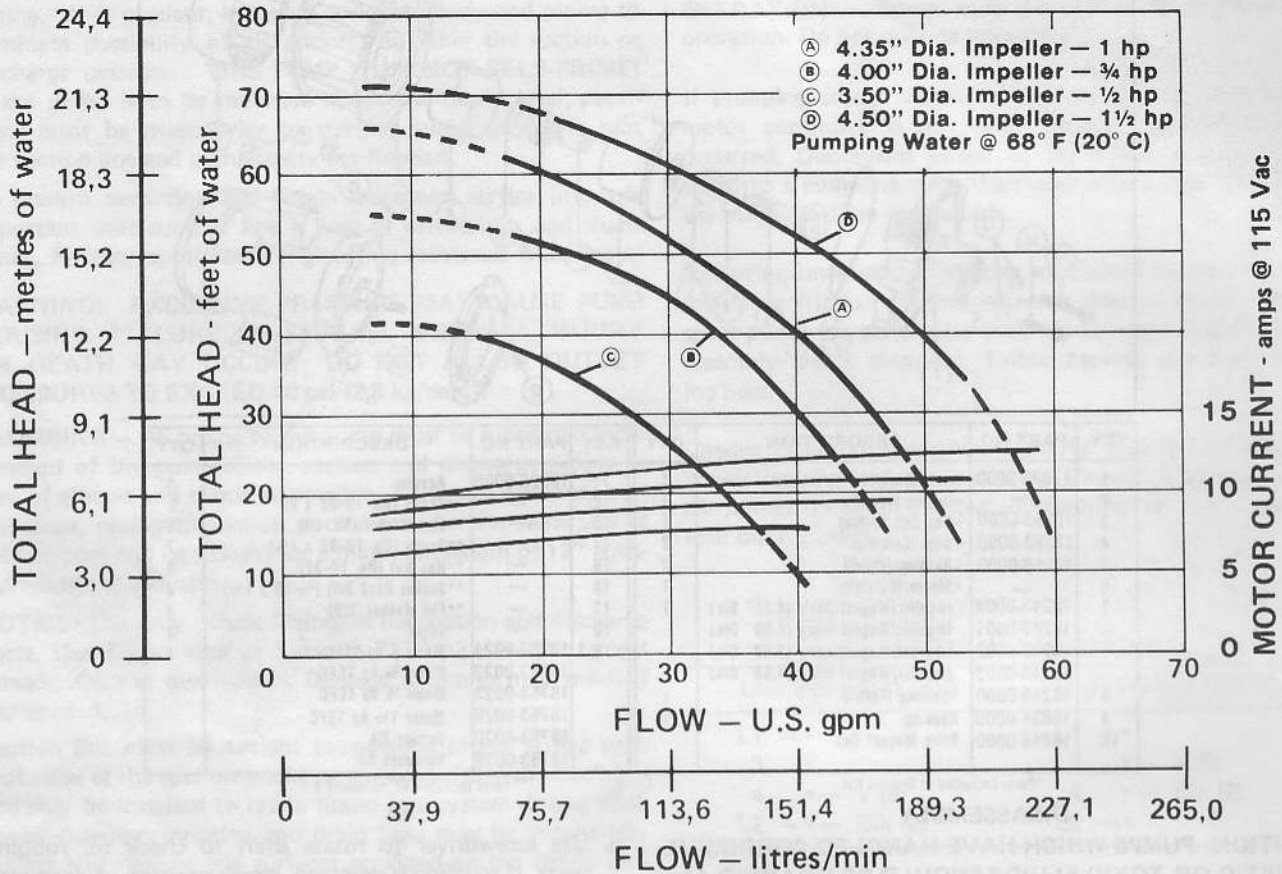

MOTOR PUMP UNIT SELECTION

The pump curves shown above are a result of test data pumping water at 68°F (20°C) at the standard 3450 RPM motor speed. A solid line indicates recommended operating range. The dashed lines indicate marginal applications and, as such, should be referred to the factory for application assistance.

SPECIFIC GRAVITY — The above pump curves are based on a 1.0 specific gravity liquid. When using a motor pump unit to pump liquids with specific gravities greater than 1.0, the motor current required increases. Should the motor current required surpass the maximum rated motor current, a motor failure may occur. The relationship between motor current required and specific gravity is expressed as follows:

$$\begin{aligned} &\text{motor current required to pump water} \\ &\times \text{specific gravity of fluid to be pumped} \\ &= \text{motor current required to pump fluid.} \end{aligned}$$

MAXIMUM RATED MOTOR CURRENT

MODEL	@ 115 Vac	@ 230 Vac
18630-0001	11.0	5.3
18630-0003	9.4	4.7
18630-0005	7.4	3.7
18630-0007	16.4	8.2

VISCOSITY — Pump performance is directly affected when handling viscous liquids. A distinct increase in required motor current, a reduction in head, and some reduction in capacity will occur with moderate and high viscosity fluids. When accurate information is required, performance tests under actual conditions should be conducted. It is recommended that fluid viscosity be limited to a maximum of 200 SSU or 50 centipoise. Consult the factory for assistance when more viscous fluids must be handled.

THE PRODUCT DESCRIBED HEREIN IS SUBJECT TO THE JABSCO ONE YEAR LIMITED WARRANTY, WHICH IS AVAILABLE FOR YOUR INSPECTION UPON REQUEST.

ITT Jabsco
 ITT Fluid Technology Corporation
 1485 Dale Way, P. O. Box 2158
 Costa Mesa, CA 92628-2158
 Telephone: (714) 545-8251