

JABSCO[®]

Model: 17200-0001

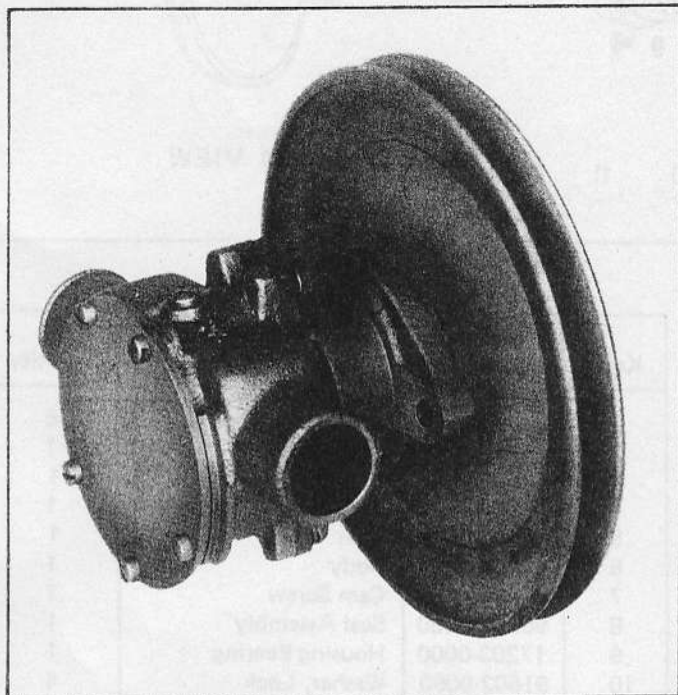

SELF-PRIMING PUMPS

FEATURES

Body:	Bronze
Impeller:	Jabasco Neoprene Compound
Shaft:	Stainless Steel
Shaft Seal:	Carbon-ceramic Face-type
Ports:	1¼" hose connection
Pulley:	7½" OD, for "A" size belt

APPLICATION

Marine Engine Cooling for Chrysler Engines
LM 318 (225) after serial number 117181
LM 340 (250) after serial number 117181
LM 383 (260) after serial number 117181
M 400 (280) after serial number 117181
M 440 (300, 330, 335 and 375) after serial number 117181
Replaces Chrysler pump numbers 3527374 and 3675763

Model: 17200-0001

MODEL 17200-0001

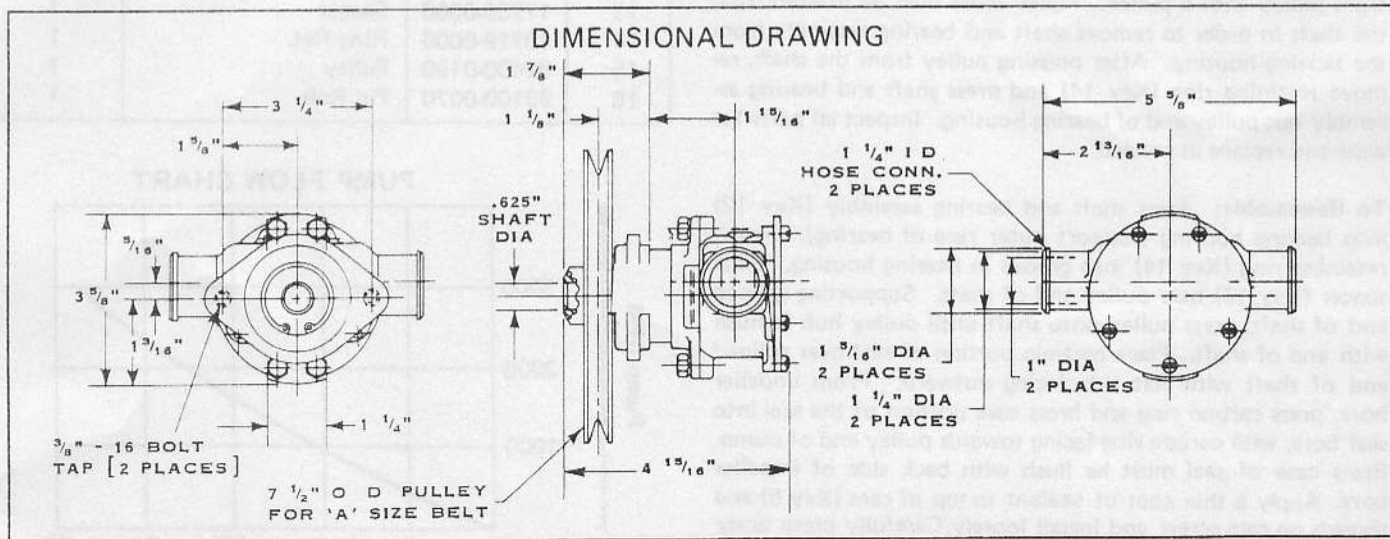

INSTALLATION INSTRUCTIONS

Mount pump on engine bracket. Make sure pump pulley is aligned with drive pulley. Tighten belt by moving bracket. Allow about ½" movement in belt when tightened. Slip inlet and outlet hoses over ports and clamp securely.

WARNING: EXPOSED PULLEYS AND BELTS CAN CAUSE INJURY. INSTALL SHIELD AROUND PULLEYS AND BELTS.

OPERATING INSTRUCTIONS

Pump will self-prime at low or high speeds. Make sure scoop and inlet line are clear and all connections airtight. Do not run pump dry for more than 30 seconds. Lack of water flow may damage impeller. To drain pump, loosen end cover screws.

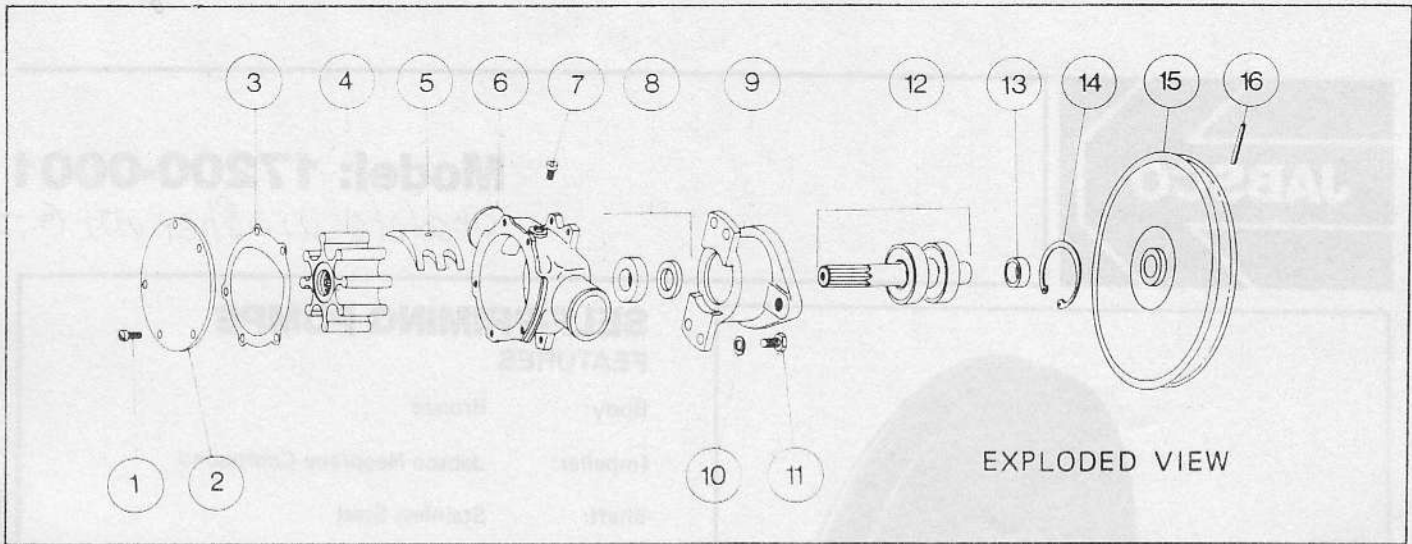

SERVICE INSTRUCTIONS

Impeller Replacement: Remove end cover and gasket. Pull impeller out by grasping hub or blades with pliers. Replace impeller, gasket, and end cover. A light coating of grease in impeller bore will aid priming on dry start up. Use correct Jabsco gasket, a thicker or thinner gasket may cause impeller damage. Standard gasket is 0.010" thick.

MAJOR REPAIR

Remove pump from engine to replace seal, bearings or shaft. To disassemble pump, first remove end cover screws, end cover, gasket, and impeller. Remove cam screw (Key 7) and cam (Key 5). Remove four bolts (Key 11) and separate body (Key 6) from bearing housing (Key 9). Slide ceramic portion of seal (Key 8) off shaft. Press remainder of seal (carbon ring in brass case) out impeller bore. Remove roll pin (Key 16) from pulley with a punch. Pulley must then be pressed from the shaft in order to remove shaft and bearing assembly from the bearing housing. After pressing pulley from the shaft, remove retaining ring (Key 14) and press shaft and bearing assembly out pulley end of bearing housing. Inspect all parts for wear and replace as needed.

To Reassemble: Press shaft and bearing assembly (Key 12) into bearing housing (support outer race of bearing). Install retaining ring (Key 14) into groove in bearing housing. Slide spacer (Key 13) over pulley end of shaft. Supporting splined end of shaft, press pulley onto shaft until pulley hub is flush with end of shaft. Place ceramic portion of seal over splined end of shaft with flat side facing outward. From impeller bore, press carbon ring and brass case portion of the seal into seal bore, with carbon ring facing towards pulley end of pump. Brass case of seal must be flush with back side of impeller bore. Apply a thin coat of sealant to top of cam (Key 5) and threads on cam screw and install loosely. Carefully place body over shaft and mate to bearing housing. Bolt body to bearing housing. Install impeller, end cover gasket, and end cover. Tighten cam screw. Install pump on engine following installation instructions.

Key	Part Number	Description	Quantity
1	91003-0010	Fil. Head Screw	5
2	14937-0000	Cover, End	1
3	10184-0000	Gasket	1
4	11979-0001	Impeller	1
5	10182-0000	Cam	1
6	17204-0000	Body	1
7	91004-0090	Cam Screw	1
8	96080-0080	Seal Assembly	1
9	17203-0000	Housing Bearing	1
10	91602-0060	Washer, Lock	4
11	91095-0320	Bolt	4
12	14206-0000	Shaft and Bearing Assy.	1
13	17239-0000	Spacer	1
14	18719-0000	Ring Ret.	1
15	92400-0190	Pulley	1
16	93100-0070	Pin Roll	1

PUMP FLOW CHART

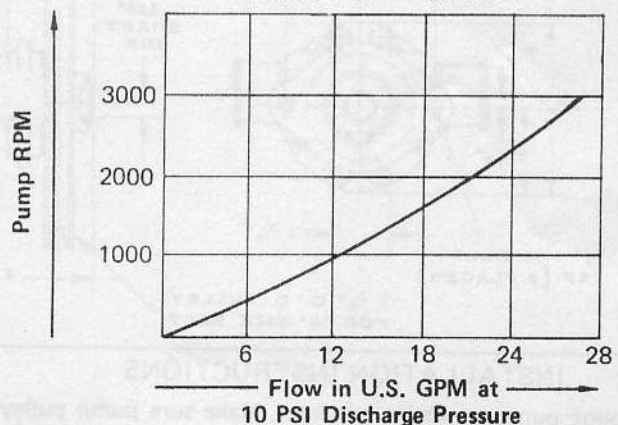

The product described herein is subject to the JABSCO one year Limited Warranty, which is available for your inspection upon request.

ITT JABSCO

A Unit of ITT Corporation
 1485 Dale Way, P.O. Box 2158
 Costa Mesa, California 92628-2158
 Telephone: (714) 545-8251