

JABSCO® PUMPS

Self-Priming Pumps

MODELS 1673-0001 (Lip Seal) 1673-9001 (Face Seal)

PRODUCT DATA

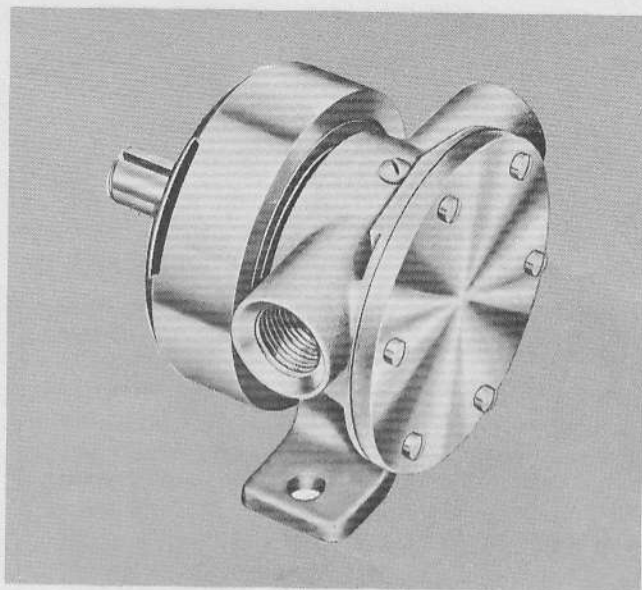

Other JABSCO models are also available in bronze, plastic, cast iron and stainless steel. JABSCO Pureflo pumps are also available for sanitary applications.

DESIGN FEATURES

Body:	Bronze
Impeller:	Neoprene, Nitrile or Polyurethane
Shaft:	Brass with Face Seal Stainless Steel with Lip Seal
Bearings:	Shielded Ball Bearing
Shaft Seal:	Mechanical Face Seal or Lip Seal
Ports:	½" NPT
Weight:	4¼ lbs. (2 kg.) approx.

VARIATIONS AVAILABLE

MODEL	VARIATIONS INCORPORATED
1673-9051	Half Thickness Cam—Face Seal (Where reduced capacity is required with a fixed speed)
1673-9003	Nitrile Impeller—Face Seal (Oil Resistant)
1673-0003	Nitrile Impeller—Lip Seal (Oil Resistant)
1673-0007	Polyurethane Impeller—Lip Seal (Handles certain dry cleaning solutions, chlorinated glues and refrigeration coil cleaners)

APPLICATIONS & OPERATING INSTRUCTIONS

MARINE: Pumping bilges, Wash-downs, Circulating water in bait tanks, Utility dock side pump, Engine cooling.

INDUSTRIAL: Circulating and transferring, Velocity-mixing, Pumping machine tool coolants, Return spill, Sump drainage, Chemicals, Pharmaceuticals, Soap, Liquors, Ink, Dyes, Alcohol, Various acids, Tanning liquors, Glycerine, Brine, etc.

FARMING: Pumping water for stock, Pumping water from shallow wells and cisterns. Pumping liquid ballast into tractor tires.

PLUMBING & HOME EMERGENCY USE: Pumping out flooded basements, Cesspools, Sumps, Water heaters and water closets, Drains and sinks, Draining fishponds and pools.

1. **INSTALLATION**—Pump may be mounted in any position. Intake and discharge ports are deter-

mined by the direction of shaft rotation (refer to Dimensional Drawing). Before installing, turn the pump shaft in the direction of the operating rotation.

2. **DRIVE**—Belt or Direct with flexible coupling.

CAUTION: Do not press a pulley or coupling on the shaft without supporting the shaft to prevent movement of the shaft into the impeller bore.

Belt Drive—Overtight belt load will reduce pump bearing life.

Direct Drive—Clearance should be left between drive shaft and pump shaft when installing coupling. Always mount and align pump and drive shaft before tightening the coupling set screw.

3. **SPEEDS**—100 RPM to the maximum shown in the performance

table. Consult the factory for operation at speeds above those shown. For longer pump life, operate at lowest possible speeds.

4. **SELF-PRIMING**—Primes at low or high speeds. For vertical dry suction lift of 10 feet (3m) a minimum of 800 RPM is required. Pump will produce suction lift up to 22 feet (6m) when wetted. **BE SURE SUCTION LINES ARE AIRTIGHT OR PUMP WILL NOT SELF-PRIME.**

5. **RUNNING DRY**—Unit depends on liquid pumped for lubrication. **DO NOT RUN DRY** for more than 30 seconds. Lack of liquid will burn the impeller.

6. **CAUTION**—If pumping light fraction petroleum derivatives, solvents, thinners, highly concentrated or organic acids, consult Jabsco "Chemical Resistant

(continued)

JABSCO PRODUCTS ITT

Form 43000-0077 Rev. 8-76

MODELS 1673-0001/1673-9001

OPERATING INSTRUCTIONS (Cont.)

Table' for proper body materials and impeller compounds. If corrosive fluids are handled, pump life will be prolonged, if flushed with water after each use or after each work day.

7. PRESSURES — Consult Head Capacity Table for recommended maximum for continuous operation. If pressures exceed those shown, consult the factory.

8. TEMPERATURES—

Neoprene 45°-180°F (7°-82°C)
Nitrile 50°-180°F (10°-82°C)
Polyurethane 45°-120°F (7°-49°C)

9. FREEZING WEATHER—Drain unit by loosening end cover. The following anti-freeze compounds can be used without any adverse effects to the neoprene impeller: Atlas "Permaguard", DuPont "Zerex" and "Telar", Dow Chemical "Dowguard" and Olin Mathison "Pyro Permanent". Most Methyl alcohol

(methanol) based anti-freeze can be used with neoprene. DO NOT USE PETROLEUM BASED ANTI-FREEZE COMPOUNDS OR RUST INHIBITORS.

10. GASKET—Use a standard pump part. Thicker gasket will reduce priming ability. A thinner gasket will cause the impeller to bind. Standard gasket is .010" thick.

11. SPARE PARTS—To avoid costly shut downs, keep a JABSCO Service Kit on hand.

EXPLODED VIEW

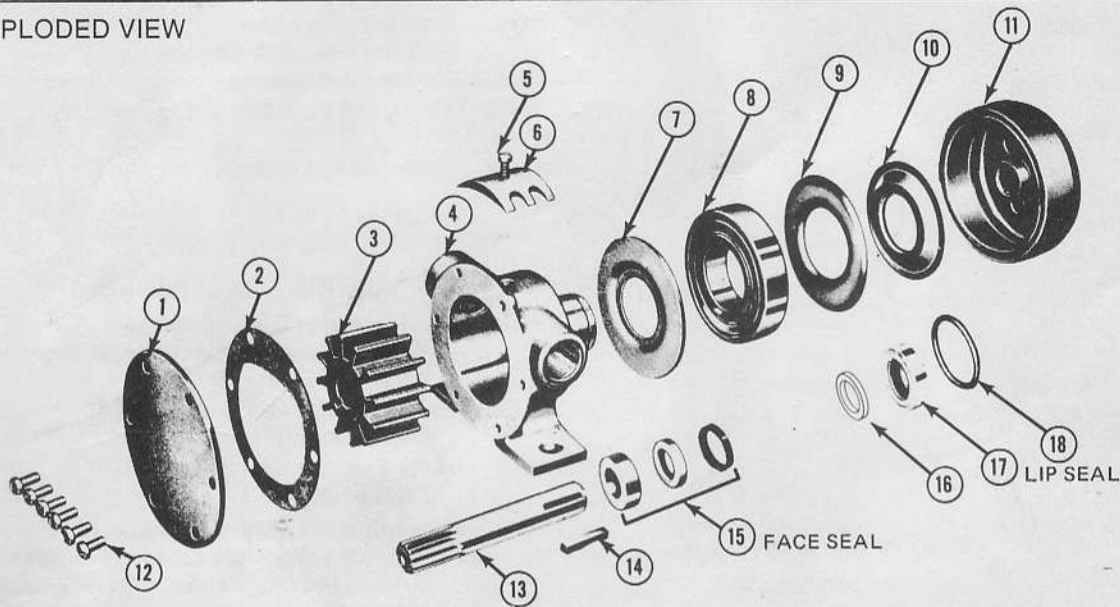

PARTS LIST

KEY	DESCRIPTION	1673-9001	1673-0001	QTY.
		Face Seal versions PART NUMBER	Lip Seal versions PART NUMBER	
1	End Cover Standard Nitrile version Polyurethane version Half-Cam version	1743-9000 1743-9370 — 1743-9050	1743-0000 1743-0370 1743-0860 —	1
2	*Gasket Standard Half-Cam version	1835-0000 2436-0000	1835-0000 —	1
3	*Impeller Neoprene Nitrile Polyurethane	1210-0001 1210-0003 —	1210-0001 1210-0003 1210-0007	1
4	Body	9094-0000	9094-0000	1
5	Screw (Cam) Standard Half-Cam version	91003-0010 91003-0090	91003-0010 —	1
6	Cam—Standard—Plastic Optional—Brass Half-Cam—Brass	490-0000 490-0001 2434-0000	490-0000 490-0001 —	1
7	Bearing Shield	3078-0000	3078-0000	1
8	Ball Bearing	92600-0330	92600-0330	1
9	Rotating Shield	1161-0000	1161-0000	1
10	Stationary Slinger	1554-0000	1554-0000	1
11	Bearing Housing	1740-0000	1740-0000	1
12	Screw (End Cover)	91003-0010	91003-0010	6
13	Shaft	1737-0410	1737-0240	1
14	Key	9215-0010	9215-0010	1
15	*Seal — Face	96080-0080	—	1
16	†Spacer	—	3166-0000	1
17	*Seal — Lip	—	92700-0060	1
18	†"O" Ring	—	92000-0210	1
	Service Kit			
	Neoprene	90119-0001	90015-0001	
	Nitrile Impeller	90119-0003	90015-0003	
	Polyurethane Impeller	—	90015-0007	

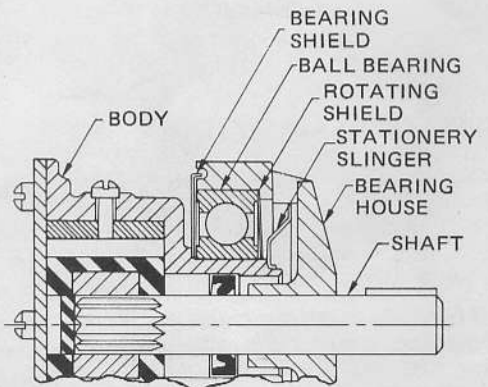

**Cross Section
to show relative
position of bearing
and slinger parts**

SERVICE INSTRUCTIONS

DISASSEMBLY

TO CHANGE IMPELLER, FOLLOW STEPS 1 & 2.

1. Remove end cover screws, end cover and gasket.
2. Remove impeller by grasping hub with water pump pliers.
3. Loosen cam screw and remove cam (clean off Permatex).
4. Remove key from shaft.
5. Remove bearing housing from bearing (requires arbor press, gear puller and hand torch) by heating housing uniformly to 325°F. Housing will expand and may be lifted off of the bearing.
6. Supporting bearing housing on internal hub, press shaft

TO CHANGE SEAL, FOLLOW STEPS 1, 2, 5, 7 & 11.

7. out of bearing housing. Press on drive end. Do not press shaft splines through the housing.
 7. Face seal version only: Remove seal seat assembly from shaft.
 8. Remove stationary slinger and rotating shield.
 9. Remove bearing from body with gear puller.
 10. Remove bearing shield from body.
 11. Remove seal assembly from seal bore by pressing from bearing end toward impeller bore.
- Note: Inspect all parts for wear or damage and replace if necessary.

ASSEMBLY

TO INSTALL NEW IMPELLER, FOLLOW STEPS 8 & 9.

1. With bearing shield between bearing and body, press bearing on body. Press on inner race of bearing. (Ref. cross section.)
2. Install rotating shield against bearing and press stationary slinger on body. (Ref. cross section.)
3. Press shaft into bearing housing. Support housing and press keyway end through shaft hole in bearing housing.
Note: When installing shaft into a used bearing housing always use the knurled replacement shaft available (#1737-0410 or #1737-0240.)
4. Heat bearing housing and shaft assembly uniformly to 325°F. and install over bearing and body assembly.
Note: Housing will shrink immediately upon contact with bearing, therefore, it must be positioned ("bottomed") quickly.
5. Install seal seat assembly on shaft against bearing hous-

TO INSTALL NEW SEAL, FOLLOW STEPS 4, 5, 6, 8 & 9.

- ing hub (gasket toward hub). Lubricate gasket with water to facilitate assembly. (Model 1673-9001)
6. Install seal assembly into seal bore (as applicable: Lip of lip seal facing impeller bore, or carbon face of face seal toward seal seat). Use care to press on outer most edge of seal case face to prevent damage to seal. Seal must be flush with back surface of impeller bore to insure proper sealing, for face seal version. Lip seal may be positioned in seal bore to clear worn area of shaft.
7. Permatex screw threads and top side of cam and install in body with cam screw.
8. Lubricate impeller bore with a light coat of Marfak 2HD grease or equivalent and start impeller into bore with a rotary motion in the intended direction of rotation until splines engage, then push into bore.
9. Install gasket and end cover and secure with end cover screws.

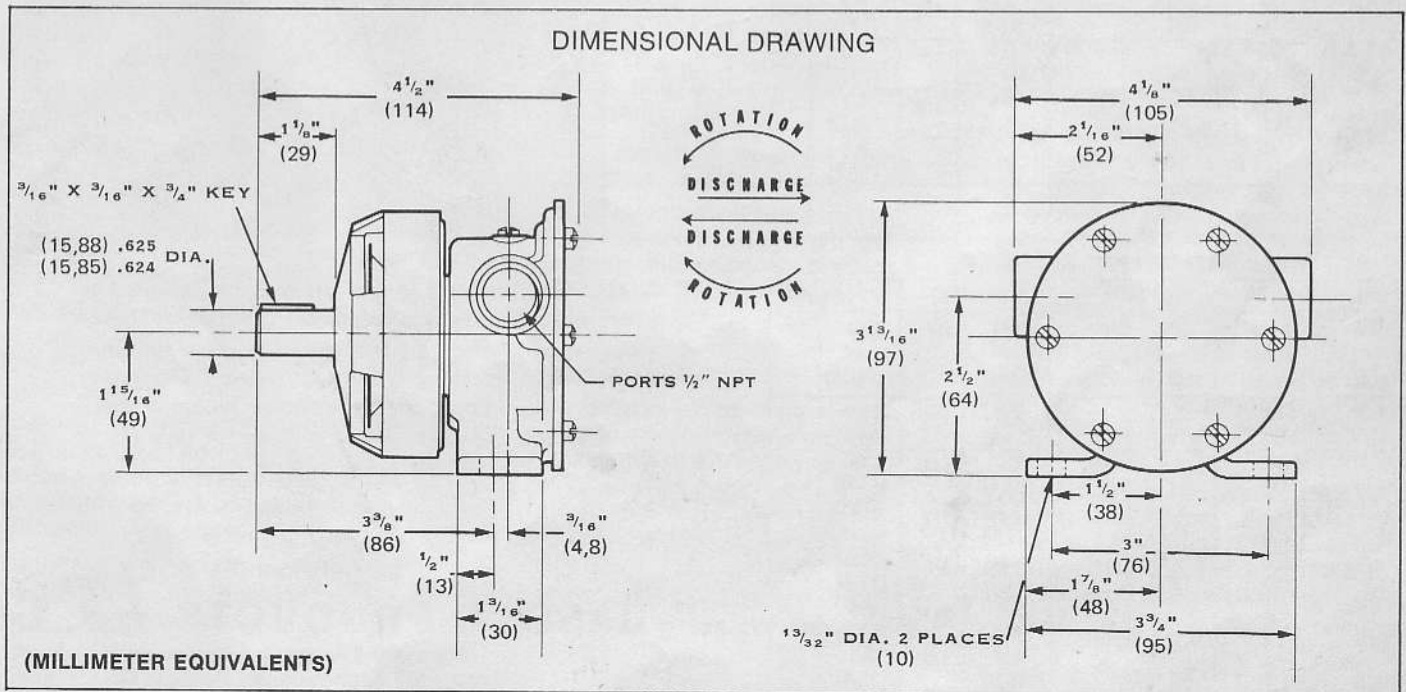

HEAD CAPACITY TABLES

1673-0001 & 1673-9001 NEOPRENE

TOTAL HEAD		500 RPM		1160 RPM		1750 RPM		2100 RPM		2450 RPM		2750 RPM		3000 RPM		3600 RPM	
P.S.I. (kg/sq cm)	Ft. of Water (meter)	GPM (L/min)	HP	GPM (L/min)	HP	GPM (L/min)	HP	GPM (L/min)	HP	GPM (L/min)	HP	GPM (L/min)	HP	GPM (L/min)	HP	GPM (L/min)	HP
4.3 (.3)	10 (3)	3.0 (11.3)	1/6	7.6 (28.7)	1/4	11.0 (41.6)	1/4	13.0 (49.2)	1/3	15.2 (57.5)	1/2	16.7 (63.2)	1/2	18.0 (68.1)	1/2	19.6 (74.2)	3/4
8.7 (.6)	20 (6)	1.8 (6.8)	1/6	6.4 (24.2)	1/4	10.0 (37.8)	1/4	11.5 (43.5)	1/3	13.7 (51.8)	1/2	15.4 (58.3)	1/2	17.0 (64.3)	1/2	18.8 (71.1)	3/4
13.0 (.9)	30 (9)	—	—	4.8 (18.2)	1/4	8.5 (32.2)	1/3	10.0 (37.8)	1/2	12.0 (45.4)	1/2	13.6 (51.5)	3/4	15.3 (57.9)	3/4	17.5 (66.2)	3/4
17.3 (1.2)	40 (12)	—	—	3.3 (12.5)	1/4	6.7 (25.3)	1/3	8.5 (32.2)	1/2	10.4 (39.3)	1/2	12.0 (45.4)	3/4	13.5 (51.1)	3/4	16.0 (60.5)	1
21.6 (1.5)	50 (15)	—	—	—	—	5.0 (18.9)	1/2	6.7 (25.3)	1/2	8.5 (32.2)	3/4	10.0 (37.8)	3/4	11.8 (44.6)	3/4	14.5 (54.9)	1
26.0 (1.8)	60 (18)	—	—	—	—	—	—	5.0 (18.9)	1/2	7.0 (26.5)	3/4	8.3 (31.4)	3/4	10.0 (37.8)	3/4	13.0 (49.2)	1
30.3 (2.1)	70 (21)	—	—	—	—	—	—	—	—	—	—	6.5 (24.6)	3/4	8.0 (30.3)	1	11.0 (41.6)	1

1673-0003 & 1673-9003 NITRILE

TOTAL HEAD		500 RPM		1160 RPM		1750 RPM		2100 RPM		2450 RPM		2750 RPM		3000 RPM		3600 RPM	
P.S.I. (kg/sq cm)	Ft. of Water (meter)	GPM (L/min)	HP	GPM (L/min)	HP	GPM (L/min)	HP	GPM (L/min)	HP	GPM (L/min)	HP	GPM (L/min)	HP	GPM (L/min)	HP	GPM (L/min)	HP
4.3 (.3)	10 (3)	2.2 (8.3)	1/8	5.8 (21.9)	1/6	9.5 (35.9)	1/4	11.5 (43.5)	1/3	13.3 (50.3)	1/2	15.0 (56.8)	1/2	16.0 (60.5)	1/2	18.2 (68.9)	3/4
8.7 (.6)	20 (6)	—	—	4.3 (16.3)	1/6	7.6 (28.7)	1/3	9.4 (35.6)	1/3	11.4 (43.1)	1/2	13.0 (49.2)	1/2	14.4 (54.5)	1/2	17.0 (64.3)	3/4
13.0 (.9)	30 (9)	—	—	2.5 (9.4)	1/6	6.0 (22.7)	1/3	7.4 (28.0)	1/2	9.3 (35.2)	1/2	11.0 (41.6)	1/2	12.6 (47.7)	3/4	15.3 (57.9)	3/4
17.3 (1.2)	40 (12)	—	—	—	—	4.2 (15.9)	1/2	5.6 (21.2)	1/2	7.5 (28.4)	1/2	9.2 (34.8)	3/4	10.8 (40.9)	3/4	13.6 (51.5)	1
21.6 (1.5)	50 (15)	—	—	—	—	—	—	3.9 (14.7)	1/2	5.7 (21.6)	3/4	7.2 (27.2)	3/4	9.0 (34.0)	3/4	11.7 (42.3)	1
26.0 (1.8)	60 (18)	—	—	—	—	—	—	—	—	—	—	5.5 (20.8)	3/4	7.1 (26.9)	3/4	9.7 (36.7)	1

1673-9051 HALF CAM, NEOPRENE

TOTAL HEAD		500 RPM		1160 RPM		1750 RPM		2100 RPM		2450 RPM		2750 RPM		3000 RPM		3600 RPM	
P.S.I. (kg/sq cm)	Ft. of Water (meter)	GPM (L/min)	HP	GPM (L/min)	HP	GPM (L/min)	HP	GPM (L/min)	HP	GPM (L/min)	HP	GPM (L/min)	HP	GPM (L/min)	HP	GPM (L/min)	HP
4.3 (.3)	10 (3)	1.6 (6.1)	1/6	4.1 (15.5)	1/6	6.3 (23.8)	1/4	7.7 (29.1)	1/3	9.0 (34.0)	1/3	10.1 (38.2)	1/2	11.0 (41.6)	1/2	13.1 (49.6)	3/4
8.7 (.6)	20 (6)	1.2 (4.5)	1/6	3.6 (13.6)	1/6	5.8 (22.0)	1/4	7.0 (26.5)	1/3	8.4 (31.8)	1/2	9.5 (35.9)	1/2	10.2 (38.6)	1/2	12.3 (46.5)	3/4
13.0 (.9)	30 (9)	—	—	3.1 (11.7)	1/6	5.0 (18.9)	1/3	6.2 (23.4)	1/3	7.6 (28.7)	1/2	8.6 (32.5)	1/2	9.4 (35.6)	3/4	11.3 (42.8)	3/4
17.3 (1.2)	40 (12)	—	—	2.4 (9.1)	1/6	4.1 (15.5)	1/3	5.3 (20.0)	1/2	6.7 (25.3)	1/2	7.7 (29.1)	3/4	8.9 (31.8)	3/4	10.3 (39.0)	3/4
21.6 (1.5)	50 (15)	—	—	—	—	3.1 (11.7)	1/3	4.2 (15.9)	1/2	5.7 (21.5)	1/2	6.7 (25.3)	3/4	7.4 (28.0)	3/4	9.2 (34.8)	3/4
26.0 (1.8)	60 (18)	—	—	—	—	—	—	—	—	4.5 (17.0)	1/2	5.6 (21.2)	3/4	6.3 (23.8)	3/4	8.1 (30.6)	3/4

1673-0007 POLYURETHANE

TOTAL HEAD		500 RPM		1160 RPM		1750 RPM	
P.S.I. (kg/sq cm)	Ft. of Water (meter)	GPM (L/min)	HP	GPM (L/min)	HP	GPM (L/min)	HP
4.3 (.3)	10 (3)	3.2 (12.1)	1/4	7.9 (29.9)	1/3	11.8 (44.6)	1/2
8.7 (.6)	20 (6)	3.0 (11.3)	1/4	7.7 (29.1)	1/3	11.6 (43.9)	1/2
17.3 (1.2)	40 (12)	2.5 (9.4)	1/4	7.3 (27.6)	1/2	11.0 (41.6)	1/2
26.0 (1.8)	60 (18)	1.8 (6.8)	1/4	6.5 (24.6)	1/2	10.0 (37.8)	3/4
34.6 (2.4)	80 (24)	—	—	5.4 (20.4)	1/2	8.8 (33.3)	3/4
43.2 (3.0)	100 (30)	—	—	4.2 (15.9)	1/2	7.5 (28.4)	3/4
52.0 (3.6)	120 (36)	—	—	—	—	6.1 (23.1)	3/4

NOTE: Progressively longer life may be expected as operating pressures and speeds are reduced. Factory Application Engineering assistance suggested for operation in light shaded area and recommended for heavy shaded area. Capacitor type motor recommended. Table shows approximate Head-Flow for new pump in U.S. gallons (and liters) per minute.

JABSCO PRODUCTS **ITT**

Marine and Recreation Components Division
International Telephone and Telegraph Corporation
1485 Dale Way, Costa Mesa, California 92626

Telephone: (714) 545-8251