

JABSCO® PUMPS

Pureflo® Sanitary

MODEL 15010 - Series
15030 - Series
15050 - Series
15070 - Series

Product Data

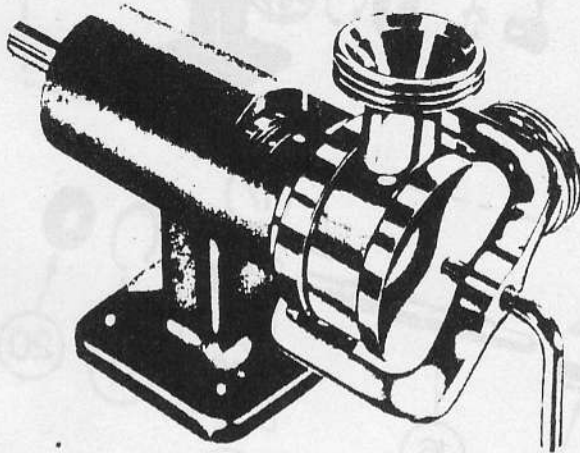

DESIGN FEATURES

Body:	Type 316 Stainless Steel		
Impeller:	Jabsco Neoprene Compound		
Shaft:	Type 316 Stainless Steel		
Seal:	Sanitary Mechanical-Carbon Face		
Bearings:	Roller and Ball Bearings		
Ports:	1½", 2" or 3". Acme Sanitary Threads with Ground Seat or Clean-in-Place (See Table Below)		
Weight:	15010-Series	9 lbs	(approx.)
	15030-Series	15 lbs	(approx.)
	15050-Series	21 lbs	(approx.)
	15070-Series	39 lbs	(approx.)

VARIATIONS AVAILABLE

Variation	Old Suffix	10 GPM	25 GPM	50 GPM	74 GPM	100 GPM
Port Size		1½"	1½"	2"	2"	3"
Old Model Number		S10-P4	S25-P4	S50-P4	S100-P4	S120-P4
Standard Neoprene Impeller and Acme Ports		15010-0665	15030-0665	15050-0665	15070-0665	15070-3655
Standard Neoprene Impeller and Clean in Place Ports	-01	15010-0765	15030-0765	15050-0765	15070-0765	
High Pressure Neoprene Impeller and Acme Ports	-12	15010-0675	15030-0675	15050-0675	**	**
High Pressure Neoprene Impeller and C.I.P. Ports	-21	15010-0775	15030-0775	15050-0775	**	
Nitrile Impeller and Acme Ports*	-N	15010-0653	15030-0663			
Nitrile Impeller and C.I.P. Ports*	-01N	15010-0763	15030-0763			

NOTE:

- * Sanitary Nitrile impellers are available in some models to handle food products having high oil content.
- ** High pressure impeller available for specific applications. See Parts List.
- *** Fragile solids impeller available for specific applications. See Parts List.

APPLICATIONS AND OPERATING INSTRUCTIONS

Some of the many diverse products handled by Jabsco Pureflo pumps include: DAIRY PROCESSING Buttermilk, Condensed Milk, Cream, Milk, Whey, Eggs and other assorted dairy products. FOOD PROCESSING Sugar Liquors, Brines, Catsup, Chocolate, Glaze, Gelatin, Honey, Jams, Jellies, Mayonnaise, Molasses, Mustard, Pickle Relish, Vinegar, Water, Yeast Slurries. BEVERAGE PROCESSING Alcohols, Beers, Brewery Slop, Cider, Distillery Wort, Extracts, Flavors, Juices, Mash, Soft Drinks, Wines. MISCELLANEOUS Chemicals, Cosmetics, Pharmaceuticals.

1. INSTALLATION—Pump may be mounted in any position. Pump head rotates 360° to permit desired port location. Intake and discharge ports are determined by the direction of shaft rotation. Before use, rotate pump shaft in direction of operating rotation.
2. DRIVE—Belt or Direct.
3. SPEEDS—100 RPM to maximum shown in performance table. Speed determines pump capacity. For maximum pump life, operate at lowest possible speeds. (Refer to the viscosity/speed chart.)
4. SELF-PRIMING—Primes at low or high speeds. For vertical dry suction lift of 12 feet, a minimum of 800 RPM is required. Pump will produce 22 feet of lift when wetted. INTAKE LINES MUST BE AIRTIGHT to prevent product foaming and assure self-priming.
5. RUNNING DRY—The impeller is lubricated by the product being pumped. DO NOT RUN DRY for more than 30 seconds. Lack of liquid may damage the impeller.
6. TEMPERATURES—40°F - 150°F. Contact factory for impeller recommendation on applications outside this range.
7. PRESSURES—Consult performance chart. When operating pressures approach the upper recommended ranges for standard pressure impellers, it is ordinarily desirable to use a high pressure model to increase impeller life. Where pressure requirements exceed the recommended range for a high pressure model, it is usually practical to utilize the next larger high pressure model at a reduced operating speed. Line losses due to product viscosity must be considered when calculating operating pressures.

JABSCO PRODUCTS **ITT**

Form 43000-0125 Rev. 1-79

MODEL 15010, 15030, 15050, 15070
PUREFLO PEDESTAL PUMPS

EXPLODED VIEW

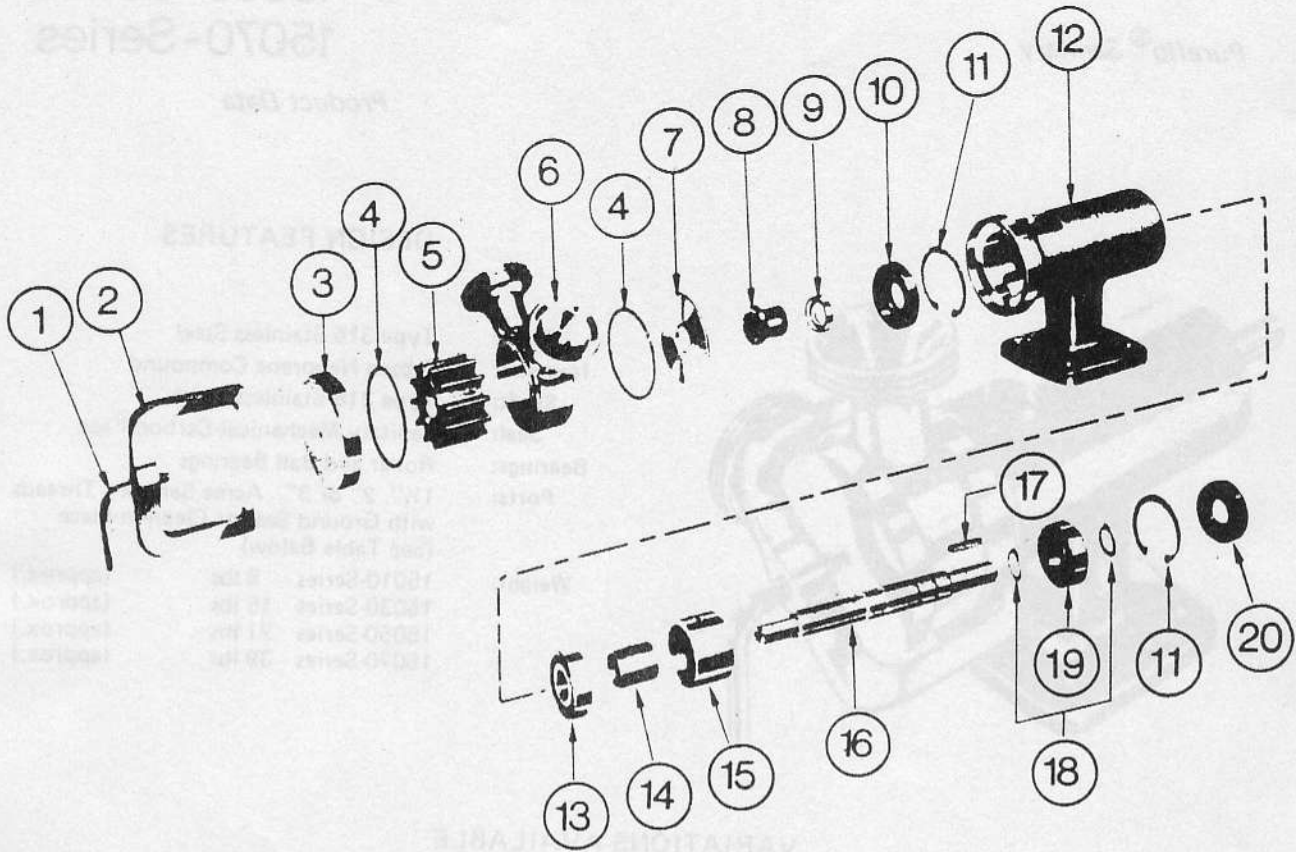

PARTS LIST

MODEL 15010-SERIES

Key	Description	Serial No. 10-A31400 thru 10-A31551, 10-A41 & Subsequent	Serial No. 10-1216 thru 10-313720, 10-41 thru 10-419	Serial Number 10-11 thru 10-1215	Qty.
		Part Number	Part Number	Part Number	
1	Clamp Screw	10408-0010	12534-0000		1
2	Clamp	12695-0000			1
3	End Cover	10435-0001	9268-0000	8253-0000	1
4*	O Ring	92000-0290	92000-0720	92000-0650	2
5*	Impeller (Standard Neoprene)	7614-0005	7614-0005	7614-0005	1
	Impeller (High Pressure Neoprene)	8980-0005	8980-0005	8980-0005	
	Impeller (Standard Nitrile)	7614-0006	7614-0006	7614-0006	
	Impeller (High Pressure Nitrile)	8980-0006	8980-0006	8980-0006	
6	Body (Acme Thread)	15014-0061			1
	Body (C.I.P.)	15014-0071			
Not Shown	O Ring (C.I.P. Port)	92000-0710	92000-0710	92000-0710	2
7	Wearplate	10396-0010	9267-0000	7806-0000	1
8*	Seal Assembly	7749-0000	7749-0000	7749-0000	1
9	Seal Collar	5307-0000	5307-0000	5307-0000	1
Not Shown*	Allen Wrench	92351-0050	92351-0050	92351-0050	1
10	Seal (Roller Bearing)	92701-0110	913-0000	913-0000	1
11	Retaining Ring (Housing)	91700-2920			2
12	Bearing Housing	12234-0000			1
13	Bearing Roller	92601-0350			1
14	Bearing Spacer (Shaft)	10693-0010			1
15	Bearing Spacer (Housing)	10449-0010			1
16	Shaft	10447-0001	7805-0000	7805-0000	1
17	Key	9215-0000	9215-0000	9215-0000	1
18	Retaining Ring (Shaft)	91700-2470 ⁽²⁾	91700-2470 ⁽¹⁾	91700-2470 ⁽¹⁾	†
19	Bearing (Ball)	92601-0330	92600-0060	92600-0060	1
20	Seal (Ball Bearing)	92701-0110	914-0000	914-0000	1
Not Shown	Service Kit (Standard Neoprene)	90072-0005			
	Service Kit (High Pressure Neoprene)	90073-0006			
	Service Kit (Standard Nitrile)	90072-0003			

See notes on center page.

PARTS LIST (continued)

MODEL 15070-SERIES
(except - 3655)

Key	Description	Serial Number	Serial Number	Serial Number	Qty.
		100-A401 and Subsequent	100-3198 thru 100-33180 & 100-41 thru 100-483	100-11 thru 100-3197	
Key	Description	Part Number	Part Number	Part Number	Qty.
1	Clamp Screw	18024-0000 ⁽¹⁾	12197-0000 ⁽¹⁾	98018-0010 ⁽²⁾	†
2	Clamp	12927-0001			1
3	End Cover	10345-0001	12531-0000		1
4*	O Ring	92000-0030	92000-0630	92000-0630	2
5*	Impeller (Std. Neo.)	8963-0005	8963-0005	8963-0005	1
	Impeller (H. P. Neoprene)	8600-0005	8600-0005	8600-0005	
	Impeller (Fragile Solids) ††	12220-0005	12220-0005		
6	Body (Acme Thread)	15074-0061			1
	Body (C.I.P.)	15074-0071			
Not Shown*	O Ring (C.I.P. Port)	92000-0730	92000-0730	92000-0730	2
7	Wearplate	10346-0010	7096-0000	7096-0000	1
8*	Seal Assembly	14052-0000	14052-0000	14052-0000	1
9	Seal Collar	8248-0000	8248-0000	8248-0000	1
Not Shown*	Allen Wrench	92351-0050	92351-0050	92351-0050	1
10	Seal (Roller Bearing)	92700-0870	92700-0860	92700-0860	1
11	Retaining Ring (Housing)	91701-4370			2
12	Bearing Housing	14028-0000			1
13	Bearing (Roller)	92601-0240			1
14	Bearing Spacer (Shaft)	10378-0010			1
15	Bearing Spacer (Housing)	10351-0010			1
16	Shaft	10347-0001			1
17	Key	8448-0000	8448-0000	8448-0000	1
18	Retaining Ring	91700-1370 ⁽²⁾	91700-2950 ⁽¹⁾	91700-2950 ⁽¹⁾	†
19	Bearing (Ball)	92601-0230	92600-0360	92600-0360	1
20	Seal (Ball Bearing)	92700-0870	3214-0000	3214-0000	1
Not Shown	Service Kit (Std. Neo.)	90080-0035			

MODEL 15070-3655

Key	Description	Serial Number	Qty.
		120-A401 and Subsequent	
Key	Description	Part Number	Qty.
1	Clamp Screw	18024-0000	1
2	Clamp	12927-0000	1
3	End Cover	10345-0001	
4*	O Ring	92000-0030	2
5*	Impeller (Standard Neoprene) ††	8963-0005	1
	Impeller (High Pressure Neoprene)	8600-0005	
	Impeller (Fragile Solids) ††	12220-0005	
6	Body (Acme Thread)	15074-0361	1
7	Wearplate	10346-0010	1
8*	Seal Assembly	14052-0000	1
9	Seal Collar	8248-0000	1
Not Shown*	Allen Wrench	92351-0050	1
10	Seal (Roller Bearing)	92700-0870	1
11	Retaining Ring (Housing)	91701-4370	2
12	Bearing Housing	14028-0000	1
13	Bearing (Roller)	92601-0240	1
14	Bearing Spacer (Shaft)	10378-0010	1
15	Bearing Spacer (Housing)	10351-0010	1
16	Shaft	10347-0001	1
17	Key	8448-0000	1
18	Retaining Ring (Shaft)	91700-1370	2
19	Bearing (Ball)	92601-0230	1
20	Seal (Ball Bearing)	92700-0870	1
Not Shown	Cam	15084-0000	1
Not Shown	Cam Screw	91025-0040	2
Not Shown	Lock-O-Seal	98022-0470	2
Not Shown	Service Kit (Standard Neoprene)	90080-0035	

†† 12220-0005 Impeller available. Limber blades for pumping fragile solids in suspension at low pressures.
See additional notes on center page.

HEAD CAPACITY TABLE

	Total Head		500 RPM		1160 RPM		1750 RPM	
	PSI	Feet of Water	GPM	H.P.	GPM	H.P.	GPM	H.P.
15010-Series Std. Press.	4.3	10	3.5	1/6	7.5	1/4	11.3	1/2
	8.7	20	3.1	1/6	6.7	1/4	10.2	1/2
	13.0	30	2.6	1/6	5.5	1/3	9.0	1/2
	21.6	50					5.2	1/2
15010-Series High Press.	8.7	20	2.9	1/6	6.9	1/3	10.4	1/2
	17.3	40	2.7	1/6	5.2	1/3	8.7	1/2
	26.0	60	2.3	1/6	3.0	1/2	6.2	1/2
	34.6	80					4.0	3/4
15030-Series Std. Press.	4.3	10	8.0	1/6	16.5	1/3	25.5	3/4
	8.7	20	7.5	1/4	16.0	1/3	24.6	3/4
	17.3	40	5.4	1/4	14.3	1/3	23.0	3/4
	26.0	60			12.8	1/2	21.0	1
15030-Series High Press.	17.3	40	7.0	1/3	15.0	3/4	22.8	1
	26.0	60	6.3	1/3	13.8	3/4	21.9	1
	34.6	80	6.0	1/2	12.4	1	20.8	1
	51.5	120	4.5	1/2	9.1	1	17.1	1-1/2
15050-Series Std. Press.	4.3	10	15.5	1/2	35.2	3/4	54.0	1-1/2
	8.7	20	15.0	1/2	33.8	3/4	52.8	1-1/2
	17.3	40	13.5	1/2	29.4	1	50.0	1-1/2
	26.0	60	11.3	1/2	23.2	1-1/2	46.0	2
15050-Series High Press.	34.6	80					41.4	3
	8.7	20	16.5	3/4	37.4	1-1/2	54.8	3
	21.6	50	15.5	3/4	36.8	2	53.7	3
	34.6	80	14.0	3/4	35.0	2	51.8	5
15070-Series (except 3655)	47.6	110	12.5	1	32.7	2	48.5	5
	60.5	140			28.5	2	43.2	5
	8.7	20	25.5	3/4	73.0	2	102.0	3
	17.3	40	20.0	1	65.0	3	91.0	5
15070-3655	21.6	50	17.0	1	61.0	3	84.0	5
	26.0	60			57.0	3	77.0	5
	30.3	70					67.0	5
	4.3	10	39.0	3/4	99.0	2		
	8.7	20	36.0	3/4	92.0	2		
	13.0	30	30.0	3/4	82.0	3		
	17.3	40			70.0	3		

Table shows approximate head-flow for new pump handling water. Use capacitor start motor. For operation at speeds not shown, contact factory for application engineering assistance. Progressively longer life may be expected as operating speeds and pressures are reduced. Table shows approximate head-flow for new pump in U.S. gallons. Contact factory for head capacity information for high pressure and fragile solids impeller; 15070 series pumps.

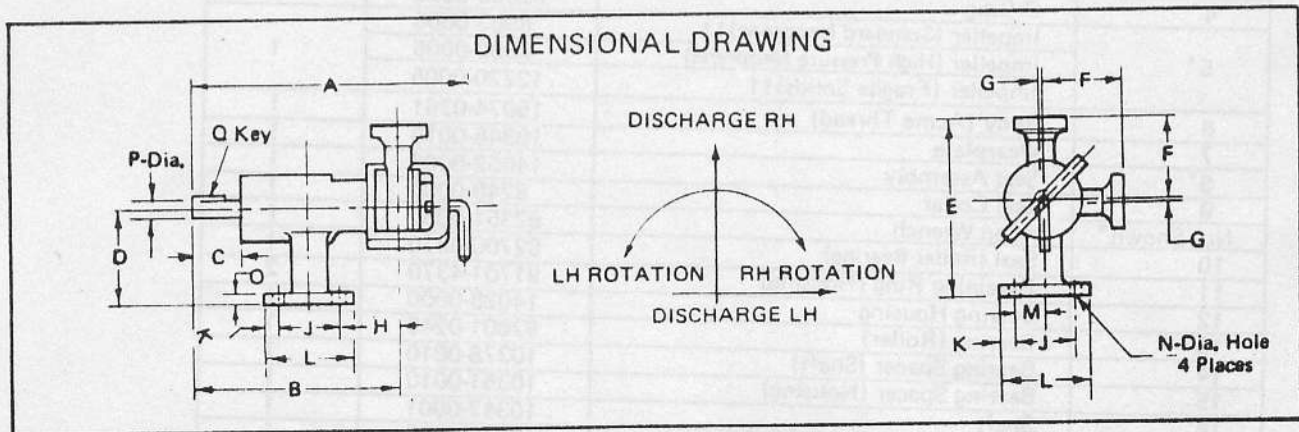

MODEL	PORT	I.D.	A	B	C	D	E	F	G	H	J	K	L	M	N	O	P	Q
15010-Series	1 1/2 Acme	3 1/8	10 3/8	7 3/8	1 3/4	3 1/2	6 7/8	2 1/8	1/8	2 1/4	2 1/4	1/2	3 1/2	1 1/8	1 3/8	3/8	5/8	3/8 x 1 1/8 x 1 1/8
	1 1/2 C.I.P.	1 1/8	10 3/8	7 3/8	1 3/4	3 1/2	6 3/4	2 3/8	1/8	2 1/4	2 1/4	1/2	3 1/2	1 1/8	1 3/8	3/8	5/8	3/8 x 1 1/8 x 1 1/8
15030-Series	1 1/2 Acme	1	12 3/8	9 3/8	2 1/8	4 1/2	7 1/8	3 3/8	1/8	2 7/8	2 3/8	1/2	3 3/8	1 1/8	1 3/8	7/8	1 1/8	3/8 x 1 1/8 x 1 1/8
	1 1/2 C.I.P.	1	12 3/8	9 3/8	2 1/8	4 1/2	7 1/8	2 3/8	1/8	2 7/8	2 3/8	1/2	3 3/8	1 1/8	1 3/8	7/8	1 1/8	3/8 x 1 1/8 x 1 1/8
15050-Series	2 Acme	1 1/4	13 3/8	10	2 3/8	4 1/2	8 3/8	3 3/8	1/8	3	2 3/8	1/2	3 3/8	1 1/8	1 3/8	7/8	1 1/8	1/2 x 1 1/8 x 1 1/8
	2 C.I.P.	1 1/8	13 3/8	10	2 3/8	4 1/2	7 3/8	3 3/8	1/8	3	2 3/8	1/2	3 3/8	1 1/8	1 3/8	7/8	1 1/8	1/2 x 1 1/8 x 1 1/8
15070-Series (Except-3655)	2 Acme	1 3/8	18 1/8	13 1/8	4 1/2	4 1/2	8 3/8	4 1/8	3/8	3 1/2	3	1/2	4	1 1/8	1 3/8	1 1/8	1 3/8	3/8 x 1 1/8 x 2
	2 C.I.P.	1 3/8	18 1/8	13 1/8	4 1/2	4 1/2	8 3/8	3 3/8	3/8	3 1/2	3	1/2	4	1 1/8	1 3/8	1 1/8	1 3/8	3/8 x 1 1/8 x 2
15070-3655	3 Acme	2 3/8	18 1/8	13 1/8	4 1/2	4 1/2	8 3/8	4 1/8	7/8	3 1/2	3	1/2	4	1 1/8	1 3/8	1 1/8	1 3/8	3/8 x 1 1/8 x 2

PARTS LIST (continued)

MODEL 15030-SERIES

Key	Description	Serial No. 25-A41 and Subsequent	Serial No. 25-11 thru 25-32370 25-41 thru 25-445	Qty.
		Part Number	Part Number	
1	Clamp Screw	9551-0010	12533-0000	1
2	Clamp	12698-0000		1
3	End Cover	10515-0001	8825-0000	1
4*	O Ring	92000-0310	92000-0690	2
5*	Impeller (Standard Neoprene)	8981-0005	8981-0005	1
	Impeller (High Pressure Neoprene)	8840-0005	8840-0005	
	Impeller (Standard Nitrile)	8840-0006	8840-0006	
6	Body (Acme Thread)	15034-0061		1
	Body (C.I.P.)	15034-0071		
Not Shown	O Ring (C.I.P. Port)	92000-0710	92000-0710	2
7	Wearplate	10046-0010	8806-0000	1
8*	Seal Assembly	8728-0000	8728-0000	1
9	Seal Collar	8727-0000	8727-0000	1
Not Shown*	Allen Wrench	92351-0050	92351-0050	1
10	Seal (Roller Bearing)	92701-0170	92700-0500	1
11	Retaining Ring (Housing)	91701-0260 ⁽²⁾	91701-4360 ⁽¹⁾	†
12	Bearing Housing	12685-0000		1
13	Bearing (Roller)	92601-0340		1
14	Bearing Spacer (Shaft)	10428-0010		1
15	Bearing Spacer (Housing)	10525-0010		1
16	Shaft	10517-0001	8828-0000	1
17	Key	9215-0000	9215-0000	1
18	Retaining Ring (Shaft)	91700-0980 ⁽²⁾	91700-2980 ⁽¹⁾	†
19	Bearing (Ball)	92601-0300	92600-0370	1
20	Seal (Ball Bearing)	92701-0170	92700-0870	1
Not Shown	Service Kit (Standard Neoprene)	90089-0005		
	Service Kit (High Pressure Neoprene)	90090-0005		
	Service Kit (Standard Nitrile)	90090-0006		

MODEL 15050-SERIES

Key	Description	Serial No. 50-A41 and Subsequent	Serial No. 50-251 thru 50-32610 and 50-41 thru 50-445	Serial No. 50-11 thru 50-250	Qty.
		Part Number	Part Number	Part Number	
1	Clamp Screw	10697-0010	12058-0000		1
2	Clamp	12996-0000			1
3	End Cover	10299-0001			1
4*	O Ring	92000-0040	92000-0740	92000-0700	2
5*	Impeller (Standard Neoprene)	14346-0005	14346-0005	14346-0005	1
	Impeller (High Pressure Neoprene)	8983-0005	8983-0005	8983-0005	
6	Body (Acme Thread)	15054-0061			1
	Body (C.I.P.)	15054-0071			
Not Shown	O Ring (C.I.P. Port)	92000-0730	92000-0730	92000-0730	2
7	Wearplate	10276-0010	8896-0000	8896-0000	1
8*	Seal Assembly	9023-0000	9023-0000	9023-0000	1
9	Seal Collar	7866-0000	7866-0000	7866-0000	1
Not Shown*	Allen Wrench	92351-0050	92351-0050	92351-0050	1
10	Seal (Roller Bearing)	92702-0780	92700-0050	92700-0050	1
11	Retaining Ring	91701-2830	91701-4360	91701-4360	1
12	Bearing Housing	12944-0000			1
13	Bearing (Ball)	92601-0280			1
14	Bearing Spacer (Shaft)	10539-0010			1
15	Bearing Spacer (Housing)	10291-0010			1
16	Shaft	10277-0001			1
17	Key	9214-0000	9214-0000	9214-0000	1
18	Retaining Ring (Shaft)	91700-1180	91700-2980 ⁽¹⁾	91700-2980 ⁽¹⁾	†
19	Bearing (Ball)	92601-0280	92600-0370	92600-0370	1
20	Seal (Ball Bearing)	92702-0780	92702-0780	92700-0870	1
Not Shown	Service Kit (Standard Neoprene)	90093-0005			1
	Service Kit (High Pressure Neoprene)	90094-0005			

* Parts supplied in Service Kit.

† Indicates a variation in quantity. Adjusted quantities are noted in parenthesis behind the part number.

NOTE: Serial number of pump, which is found on the label, must be specified when ordering parts.

Explanation of Serial Numbers:

1. Effective March 30, 1970 the serial number consists of Month and Year of manufacture, e.g. 570 = May, 1970.

2. Prior to March, 1970

The first part of the serial number denotes the capacity of the pump. For example, serial number 100-3021 was used on a 100 GPM pump. The first number in the second series of digits denotes the year the pump was manufactured. For example, serial number 100-3021 reveals the pump was produced in 1963. The use of this digit is VERY IMPORTANT. A pump bearing the serial number 100-401 is a "later" number than serial number 100-3021. Pumps with serial numbers containing letter "A" are of more recent design, except as noted in 1 above.

**SERVICE INSTRUCTIONS
ALL MODEL PUMPS**

ASSEMBLY AND DISASSEMBLY OF PUMP HEAD

Before using pump it should be disassembled and cleaned to remove any dust and dirt resulting from storage or shipping. Wash parts in standard cleaning solutions approved for handling stainless steel. Thoroughly rinse before reassembly. **DO NOT USE IODINE BASED SANITIZERS** as the iodine attacks the elastomer materials used in the impeller. All parts have been expertly machined and polished. **HANDLE WITH CARE. DO NOT DROP OR MISHANDLE.**

DISASSEMBLY:

1. Remove end cover clamp, end cover and "O" ring.
2. Grasp pump ports and slide pump body and impeller from shaft.
3. Remove "O" ring and then push the impeller from the pump body.
4. Remove wearplate from pump.

5. Slide seal assembly off the shaft. Do not damage the carbon seal face in handling. Do not loosen or remove seal collar, except as noted below.

ASSEMBLY:

1. Slide seal assembly onto shaft (carbon face toward pump head).
2. Replace wearplate. **BE SURE THAT FLAT SIDE IS TOWARD PUMP HEAD AND THE SIDE WITH THE RAISED BOSS IS TOWARD CARBON FACE OF SEAL ASSEMBLY.**
3. Lubricate bore of pump body with Orange Solid Grease or suitable substitute and then replace impeller into pump body by twisting and pushing at same time.
4. Replace two "O" rings on either side of body and install assembly on shaft. (Impeller blades bent under cam should point in opposite direction to operational rotation.)

5. Position end cover and then replace end cover clamp. **CLAMP SHOULD BE HAND TIGHTENED.** Do not use wrench or hammer.

NOTE: The seal collar is set at the factory to provide proper seal compression and should not require further adjustment.

If adjustment is required:

With pump head disassembled; loosen two set screws on seal collar. Replace seal assembly on shaft and then install wearplate in *Reverse Position* with flat side toward seal. While holding wearplate in position against adapter, push seal assembly and seal collar against wearplate and tighten the two set screws in seal collar. Remove wearplate and replace to correct position with raised boss against carbon face of seal before assembling pump. **DO NOT ASSEMBLE PUMP WITH WEARPLATE IN REVERSE POSITION.**

DETAILED DISASSEMBLY AND ASSEMBLY OF BEARING HOUSING

DISASSEMBLY

1. Loosen set screws in seal collar. Remove seal collar from shaft.
2. Pry outer bearing seal from rear of bearing housing by inserting a screwdriver blade between O.D. of seal and housing bore. Remove housing retaining ring using retaining ring pliers.
3. Push on impeller drive end of shaft to remove shaft and bearing assembly. Outer race of front bearing and housing bearing will remain in housing.
4. Remove housing bearing spacer from housing.
5. Pry or tap out front bearing seal from housing bore and remove front retaining ring with retaining ring pliers.
6. Push outer race of front bearing from housing.
7. Remove retaining rings from shaft with retaining ring pliers. Use an arbor press to remove bearings from shaft.

Roller bearing presses off toward impeller and ball bearing presses off toward drive end of shaft. Remove bearing spacer.

ASSEMBLY

1. Push outer race of roller bearing into housing from impeller end. Install front housing retaining ring. Push outer race up against housing retaining ring.
2. Press front bearing seal into housing against front housing retaining ring (spring of lip seal faces outward).
3. Install large diameter bearing spacer into housing against outer race of bearing.
4. To replace bearing shaft
 - (a) Install front shaft retaining ring.
 - (b) Press ball bearing on shaft against retaining ring (drive end of shaft).
 - (c) Install rear shaft retaining ring

against ball bearing.

- (d) Slide bearing spacer on shaft up to front retaining ring.
- (e) Press roller bearing on shaft from impeller drive end up to spacer.
5. Liberally coat bearing race areas of bearings with Shell-alvania Grease No. 2 or equal. Do not overpack with grease or overheating will result.
6. From rear of housing, insert shaft/bearing assembly roller bearing first into housing taking care not to damage front bearing seal or bearings.
7. Install rear bearing housing retaining ring.
8. Press rear bearing seal into housing against retaining ring (with lip seal spring outward).
9. Replace seal collar, position and secure as described in instructions on assembly and disassembly of pump head components.

Pump Speed Selection According to Product Viscosity

Viscosity S.S.U.	Pump Speed (Max. RPM)	Viscosity S.S.U.	Pump Speed (M. RPM)	Viscosity S.S.U.	Pump Speed (Max. RPM)	Viscosity S.S.U.	Pump Speed (Max. RPM)
50	1750	600	1715	4,000	1400	15,000*	787
100	1750	700	1680	5,000	1312	20,000*	700
200	1750	800	1645	6,000	1225	30,000*	612
300	1750	900	1610	7,000	1138	40,000*	525
400	1750	1,000	1575	8,000	1050	50,000*	437
500	1750	1,500	1540	9,000	962	75,000*	298
		2,000	1505	10,000	875	100,000*	175
		3,000	1450			*Use High Pressure Impeller	

JABSCO PRODUCTS 

A Unit of International Telephone and Telegraph Corporation, 1485 Dale Way, Costa Mesa, California 92626
Telephone: (714) 545-8251