

**JABSCO**

## Model 12490-SERIES

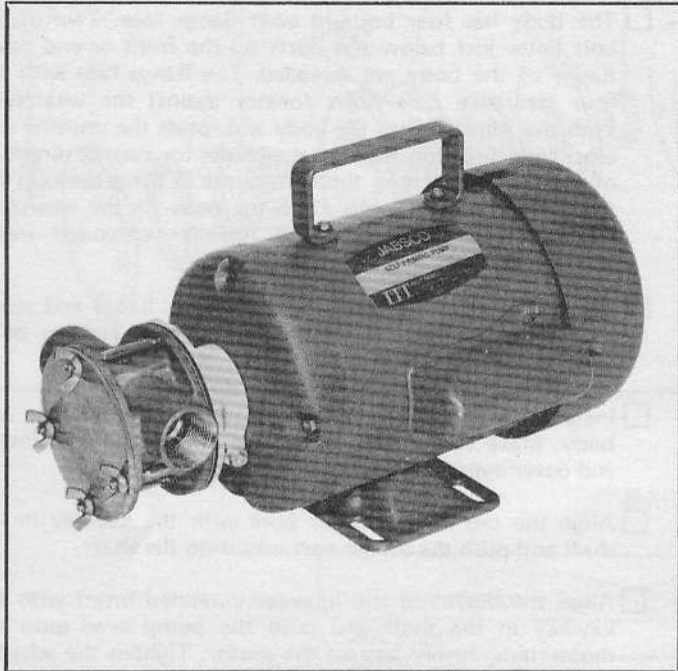

### SELF-PRIMING PUMPS FEATURES

Body: Type 316 Stainless Steel  
 Impeller: Neoprene and Nitrile  
 Seal: Lip Type – Stainless Steel Case  
 Shaft: Steel Motor Shaft – with special Stainless Steel Sleeve  
 Ports: 1" NPT Internal  
 Motor: 3/4 HP, 1725 RPM, 60 Hz Single Phase, 115/230 Vac, Continuous Duty Totally Enclosed Fan Cooled, 56 Frame, Capacitor Start, Thermal Overload Protection with Automatic Reset, Carrying Handle, 6' Cord with 3 Prong Grounded Plug.  
 Weight: 35 lb (15,9 kg)

Model 12490-SERIES

MODEL	DESCRIPTION
12490-0001	Neoprene Impeller
12490-0003	Nitrile Impeller

#### ⚠ MOTOR WARNING



MOTOR CAN SPARK.  
EXPLOSION & DEATH  
CAN OCCUR.

DO NOT USE WHERE  
FLAMMABLE VAPORS  
ARE PRESENT.

### APPLICATIONS

**CHEMICAL** – Industrial Motor Pump Unit Circulating, Transferring and Filtering of Chemicals, Plating Solutions, Pharmaceuticals, Cosmetics and Farm Chemicals, Emptying and Filling Carboys, Vats, Tanks, Barrels or Entire Systems.

### OPERATING INSTRUCTIONS

**INSTALLATION** – Pump may be installed in any position. Rotation of motor determines the location of the pump intake. The motor is normally wired for clockwise rotation when looking at pump cover with inlet port on the right.

**SELF-PRIMING** – Vertical, dry suction lift of 10' (3,1m). Pump will produce suction lift up to 22' (6,7m) when wet. **BE SURE SUCTION LINES ARE AIRTIGHT** or pump will not self-prime.

**DISCHARGE** – Use 1" ID discharge line when transferring liquids to 25' (7,6m); use 1-1/2" ID discharge line to 75' (22,9m).

**RUNNING DRY** – Unit depends on liquid pumped for lubrication. **DO NOT RUN DRY FOR MORE THAN 30 SECONDS.** Lack of liquid will damage the impeller and seal.

**NOTICE** – If pumping light fraction petroleum derivatives, solvents, thinners, highly concentrated or organic acids, consult Jabsco Chemical Resistance Table (which is available upon request from ITT Jabsco) for proper body materials and impeller compounds. If corrosive fluids are handled, pump life will be prolonged if pump is flushed with water after each use or after each work day.

**PRESSURES** – For continuous operation, pressure should not exceed 20 PSI (1,4 kg/sq cm).

**TEMPERATURE** – Neoprene Impeller 45° to 180° F (7° to 82°C). Nitrile Impeller 50° to 180° F (10° to 82°C).

**SPARE PARTS** – A Jabsco Service Kit should be kept on hand to maintain all but the most badly worn pumps.

## ● DISASSEMBLY STEPS

**CAUTION: PUMPS WHICH HAVE HANDLED CORROSIVE, CAUSTIC OR TOXIC FLUIDS SHOULD BE DRAINED AND COMPLETELY FLUSHED PRIOR TO SERVICING. FAILURE TO DO SO MAY CAUSE INJURY.**

### TO REPLACE IMPELLER

- Remove wing nuts and end cover.
- Grasp impeller hub with water pump pliers and withdraw impeller from body. Check seal and internal parts for wear. Replace worn parts if necessary.
- Coat body bore and end of impeller extended insert with a light film of water pump grease. Align detent in impeller extended insert with keyway in shaft. Depress the two impeller blades which fit under the cam, and carefully push the impeller into the body bore. Use a screwdriver in the drain slot area to push the neoprene slinger up onto the end of the extended insert. Rotate the impeller in a clockwise direction to assure the impeller blades are in the correct position for easy starting.
- Replace end cover and secure with wing nuts.

### TO REPLACE SEAL ASSEMBLY

- Loosen adaptor clamp nut and remove pump head from motor. Use a screwdriver to spread the clamp slightly to facilitate removal.
- Remove wing nuts, end cover, top and bottom bolts.
- Unscrew remaining two bolts from body. Remove body and wearplate from adaptor. Push impeller from body bore.
- Remove seal liner and seal by pressing from motor end of adaptor.
- Remove seal from liner. Check all parts for wear. Replace if questionable.

## ASSEMBLY STEPS

- Install seal liner in bore of adaptor, aligning bolt holes carefully.
- Dip lip seal in water for lubrication and push into seal liner bore with lip of seal facing outwards. Wipe a thin film of grease on lip of seal.
- Install wearplate against liner. Align bolt holes.
- The body has four bolts in each flange face. Two of the bolt holes just below the ports on the front or end cover flange of the body are threaded. The flange face with the four clearance bolt holes locates against the wearplate. Push the impeller into the body and rotate the impeller in a clockwise direction to align the blades for correct direction of rotation. Make sure the O-rings are in the grooves in the flange faces of the body. Place the body on the wearplate while carefully inserting the impeller extended insert through the seal.
- Install the two bolts through the adaptor flange and screw into threaded holes in front body flange. Tighten bolts evenly and securely.
- Install top and bottom bolts through adaptor flange and body. Make sure O-ring is in place in body groove. Install end cover over four bolts and secure with wing nuts.
- Align the tab in the slinger bore with the keyway in the shaft and push the slinger part way onto the shaft.
- Align the detent in the impeller extended insert with the keyway in the shaft and push the pump head onto the motor hub, firmly against the motor. Tighten the adaptor clamp nut just enough to prevent the pump head from turning on the motor hub. If too tight, motor bearing will seize the shaft and become damaged during operation. Attach short lengths of hose to suction and discharge ports and place both hose ends in a bucket of water before plugging motor in, to check operation.



EXPLODED VIEW

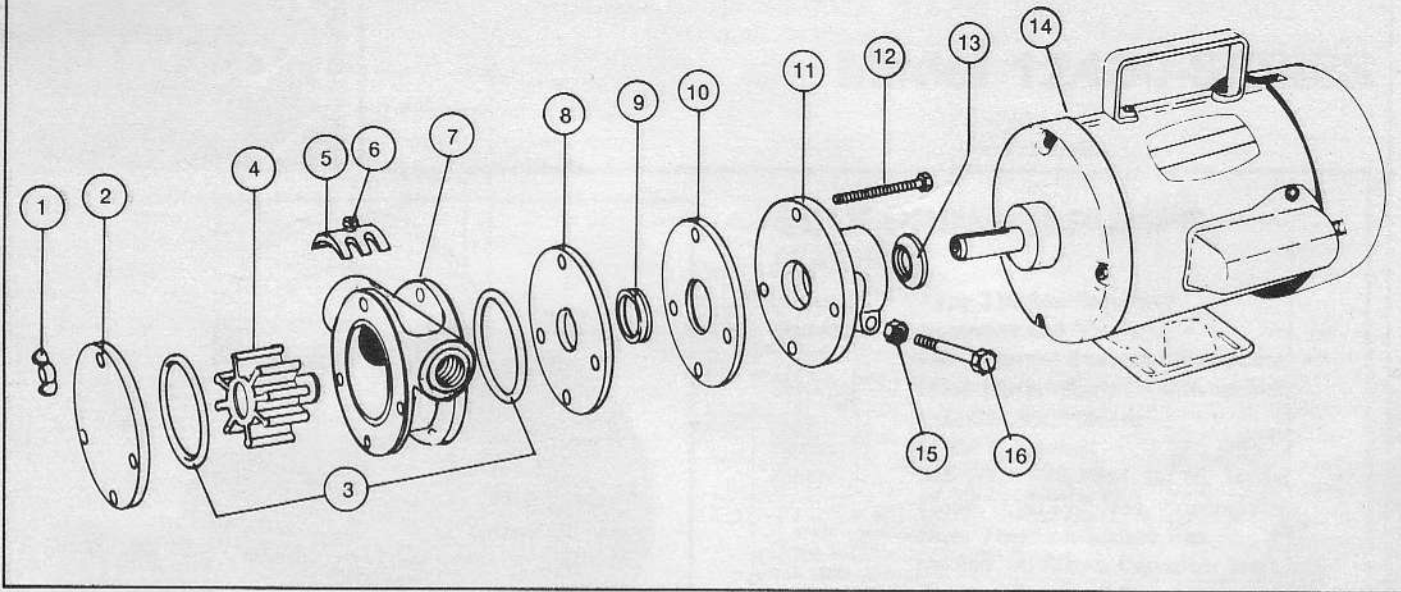

PARTS LIST

Key	Description	Part Number	Qty. Req.
1	Wing Nut	91107-0030	4
2	End Cover	12074-0000	1
3	* O-Ring	92000-0310	2
4	*Impeller Neoprene	12326-0001	1
	Nitrile	12326-0003	
5	Cam	1029-0000	1
6	Cam Screw	91030-0020	1
7	Body	468-0000	1
8	Wearplate	4357-0000	1
9	*Seal	92700-0520	1
10	Liner	4354-0000	1
11	Adaptor	4355-0000	1
12	Bolt (Body)	91106-0150	4
13	Slinger	6398-0000	1
14	Motor (Includes Handle, Cord, and Plug)	18738-0000	1
15	Nut (Adaptor)	91105-0030	1
16	Bolt (Adaptor)	91095-0090	1
—	Replacement Pump Head Model 12490-0001	12498-0001	—
	Model 12490-0003	12498-0003	—
—	Service Kit Model 12490-0001	90123-0001	—
	Model 12490-0003	90123-0003	—

\*Part Supplied in Service Kit

**DIMENSIONAL DRAWING  
INCHES (MILLIMETRES)**

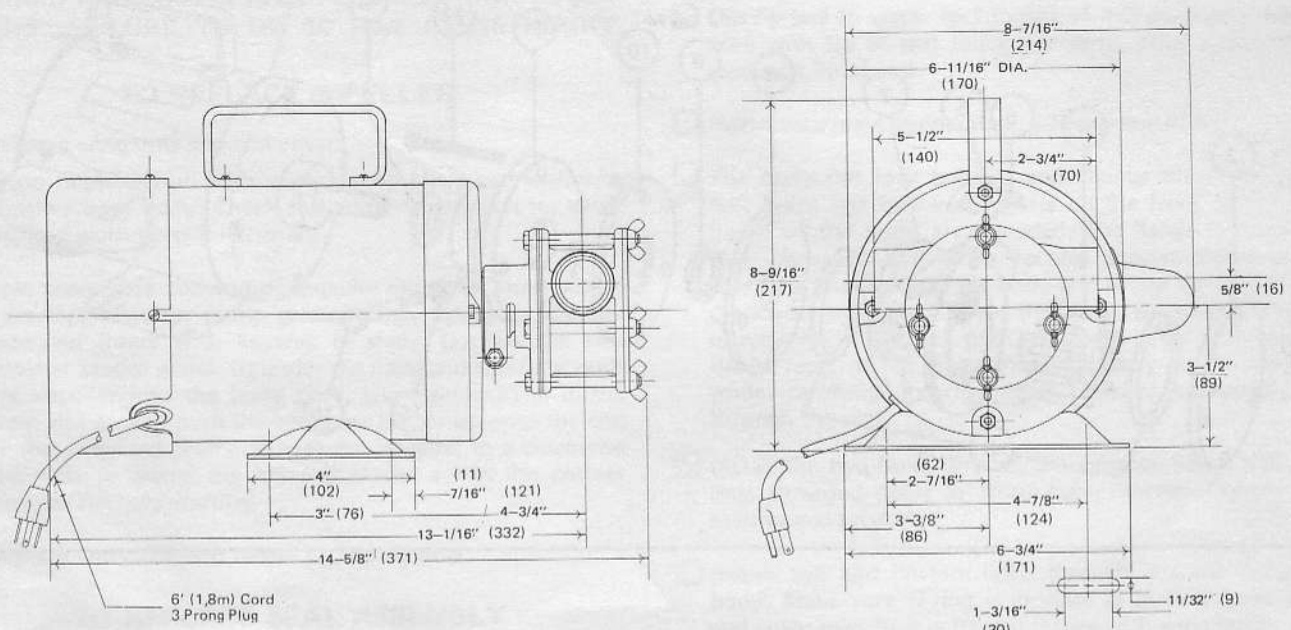

**HEAD CAPACITY TABLE**

PSI	TOTAL HEAD			FLOW AT 1725 RPM	
	kgs per sq cm	feet of water	metres of water	GPM	litres of water
4.3	0,3	10	3,0	26.0	98,4
8.7	0,6	20	6,1	24.5	92,7
17.3	1,2	40	12,2	21.0	79,5
26.0	1,8	60	18,3	16.5	62,5

Progressively longer life may be expected as operating pressures are reduced.

Table shows approximate head-flow for new pump with neoprene impeller in U.S. gallons and litres.

THE PRODUCTS DESCRIBED HEREIN ARE SUBJECT TO THE JABSCO ONE YEAR LIMITED WARRANTY, WHICH IS AVAILABLE FOR YOUR INSPECTION UPON REQUEST.

**ITT JABSCO**  
A Unit of ITT Corporation  
1485 Dale Way, P.O. Box 2158  
Costa Mesa, CA 92628-2158  
Telephone: (714) 545-8251  
Form: 43000-0193 Rev. 12/89