

a xylem brand

SELF-PRIMING PUMP

FEATURES

Body:	Bronze
Impeller:	Jabsco Neoprene Compound
Shaft:	Bronze
Shaft Seal:	Carbon-Ceramic Face Type
Ports:	3/4" NPT
Shipping Weight:	4 lb (1,8 kg) (approx.)

APPLICATION

Marine Engine Cooling	Circulating
Pumping Bilges	Transfers
Washdowns	Sump Drainage
	Spill Returns



Model 3890-9011

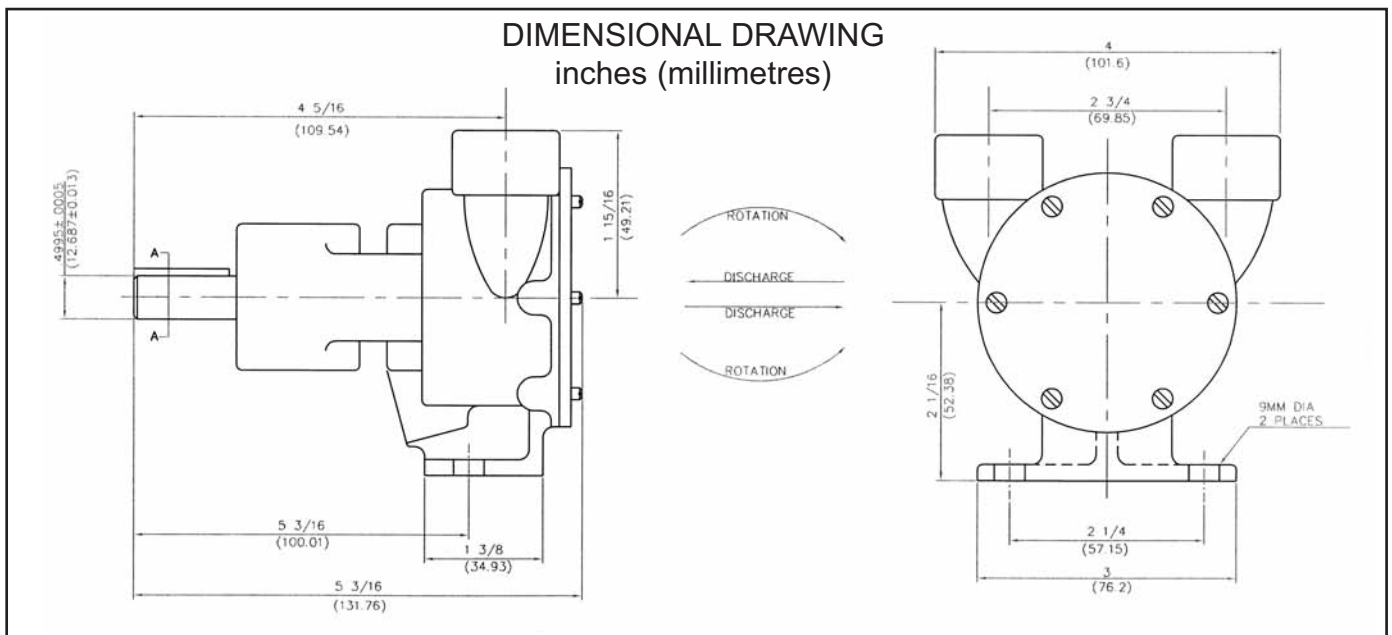

INSTALLATION INSTRUCTIONS

Pump may be mounted in any position. The rotation of the pump shaft determines the location of the pump's intake and discharge ports (refer to dimensional drawing). Before installing, turn the pump shaft in the direction of the operating rotation.

DRIVE ✓ Belt or Direct with flexible coupling.

WARNING



Injury hazard. Exposed pulleys and belts can cause injury. Install shield around pulleys and belts. Stay clear while machinery is operating.

Direct Drive ✓ Clearance should be left between drive shaft and pump shaft when installing coupling. Always mount and align pump and drive shaft before tightening the coupling set screw.

NOTICE: If drive pulley or coupling must be pressed on shaft, remove end cover and impeller and support shaft from impeller end during press operation. Do not hammer a pulley or coupling on shaft. Failure to follow above instructions can damage the pump.

OPERATING INSTRUCTIONS

Pump will self-prime at low or high speeds. Make sure inlet line is clear and all connections airtight. Do not run pump dry for more than 30 seconds. Lack of water flow may damage impeller. To drain pump, loosen end cover screws.

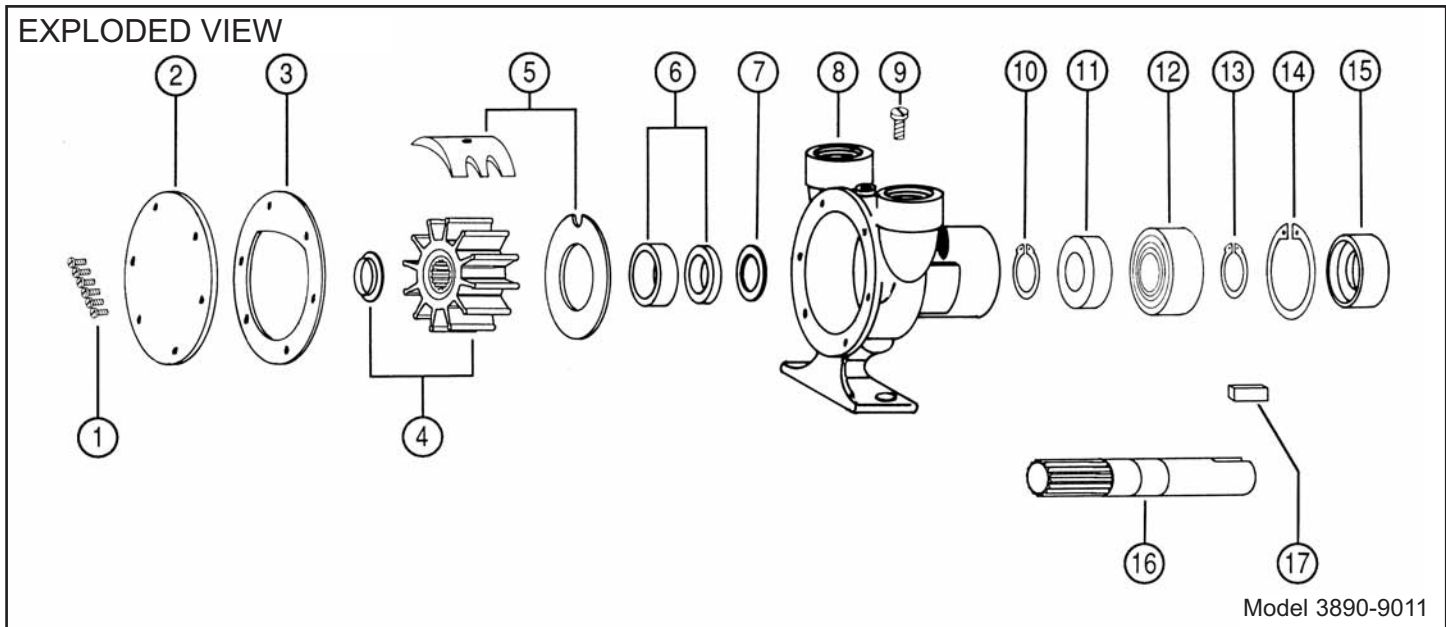

Model 3890-9011

SERVICE INSTRUCTIONS

Impeller Replacement: Remove end cover and gasket. Remove impeller using the Impeller Removal Tool (50070-0040). Replace impeller, gasket and end cover. A light coating of grease in impeller bore will aid priming on dry start up. (Use correct Jabsco gasket; a thicker or thinner gasket may cause impeller damage.) Standard gasket is .010" thick.

Major Repair: Remove pump from mount to replace seal assembly, bearings, or shaft.

Disassembly: Remove end cover and gasket. Remove impeller. Loosen cam screw and tap down to loosen cam. Remove cam screw, cam and wearplate. Remove sealant from cam and cam screw. From drive end of pump, remove outer bearing seal by prying with screwdriver. Remove bearing to body retaining ring (Key 14). By pressing on impeller end of shaft, force shaft and bearing assembly out of body. Slide ceramic portion of seal assembly and washer out drain area (center of body). Remove inner bearing seal. With a screw-driver inserted through the bearing bore, drive the seal out through the impeller bore. Remove shaft retaining ring (Key 10) from shaft (do not scratch shaft). Remove bearing to shaft retaining ring (Key 13), and supporting inner race of bearing, press bearing off over drive end of shaft.

Assembly: Replace worn or broken parts. Lubricate inner bearing seal with water pump grease or equivalent, and press into body bearing seal bore with lip facing impeller bore. Press bearing onto well-oiled shaft. Install bearing to shaft retaining ring. Place shaft and bearing assembly (splined end first) into body bearing bore and press on bearing outer race until in place. Install bearing to body retaining ring and press outer bearing seal into place (lip facing drive end). Using long nosed retaining ring pliers, place shaft retaining ring over splined end of shaft and into groove. (Do not scratch shaft.) Location of shaft retaining ring may be observed through drain area (center of body).

Slide washer over splined end of shaft and up against shaft retaining ring. Place ceramic portion of seal assembly over splined end of shaft and up against washer (flat side of ceramic seat must face impeller bore). Lubricate with water (do not use oil) to ease assembly. Apply a light coat of sealant to the OD of seal, and, with carbon facing ceramic, press on outer edge of seal seat until flush with rear of impeller bore. Install wearplate with small notch facing up. Seal threads of cam screw and top of cam and install loosely. Lubricate impeller bore with a light coat of water pump grease and install impeller. Install gasket and end cover. Tighten cam screw.

PARTS LIST

1	Screws (end cover)	SP1002-02	6
2	End Cover	11830-0000	1
3	*Gasket	3298	1
4	*Impeller	1210-0101	1
5	Cam & Wearplate Assy.	7876-6000	1
6	*Seal Assembly	96080-6080	1
7	Washer	723-6000	1
8	Body	3894-9010	1
9	Screw (cam)	SP1003-01	1
10	Retaining Ring (shaft)	SP1700-62	1
11	Bearing Seal (inner)	92700-6060	1
12	Ball Bearing	SP2600-07	1
13	Retaining Ring (Brg. to shaft)	SP1700-249	1
14	Retaining Ring (Brg. to body)	SP1700-248	1
15	Bearing Seal (outer)	SP2700-60	1
16	Shaft	18701-0000	1
17	Key (Pump Drive)	11847-6000	1
	Service Kit		

* Parts Contained in Service Kit.
Models 3890 & 3890-01, built prior to 1962, use Lip Seal No.92700-6060, Service Kit No. 90111-0011.

Warranty: All products of the company are sold and all services of the company are offered subject to the company's warranty and terms and conditions of sale, copies of which will be furnished upon request. The information provided herein is for guidance only, it does not constitute a guarantee of the performance or specification of any individual product or component.

www.xylemflowcontrol.com

Jabsco, 100 Cummings Center, Ste. 535-N, Beverly, MA 01915
Tel: +1 978 281 0440 Fax: +1 978 283 2619

Jabsco, Bingley Road, Hoddesdon, Hertfordshire, EN11 0BU
Tel: +44 (0) 1992 450 145 Fax: +44 (0) 1992 467 132

NHK Jabsco Co Ltd, 3-21-10, Shin - Yokohama Kohoku-ku, Yokohama 222
Tel: +81 (0) 45 475 8906 Fax: +81 (0) 45 475 8908

Jabsco GmbH, Oststraße 28, 22844 Norderstedt
Tel: +49 (0) 40 53 53 73 0 Fax: +49 (0) 49 53 53 73 11

Jabsco Italia, s.r.l., Via Tommaseo, 6, 20059 Vimercate, Milano
Tel: +39 039 685 2323 Fax: +39 039 666 307

USA
UK
JAPAN
GERMANY
ITALY



a xylem brand