

Models 30510-0XXX

SELF-PRIMING PUMPS FEATURES

Pump Type:	Pedestal Pump
Body:	316 Stainless Steel
Impeller:	Neoprene, Nitrile, Viton* or EPDM
Shaft Seal:	Mechanical; Carbon-on-Ceramic, or Tungsten Carbide; Nitrile or Viton
Ports:	3/4" NPT Internal
Shaft:	316 Stainless Steel
Weight:	5.5 lb (2,5 kg) Approx.

VARIATIONS AVAILABLE

MODEL NO.	DESCRIPTION
30510-0001	Standard Pressure, Neoprene Impeller, Carbon Seal
30510-0003	Standard Pressure, Nitrile Impeller, Carbon Seal
30510-0004	Standard Pressure, Viton Impeller, Carbon Seal
30510-0011	High Pressure, Neoprene Impeller, Carbon Seal
30510-0013	High Pressure, Nitrile Impeller, Carbon Seal
30510-0014	High Pressure, Viton Impeller, Carbon Seal
30510-0101	Standard Pressure, Neoprene Impeller, Tungsten Carbide Seal
30510-0103	Standard Pressure, Nitrile Impeller, Tungsten Carbide Seal
30510-0104	Standard Pressure, Viton Impeller, Tungsten Carbide Seal
30510-0111	High Pressure, Neoprene Impeller, Tungsten Carbide Seal
30510-0113	High Pressure, Nitrile Impeller, Tungsten Carbide Seal
30510-0114	High Pressure, Viton Impeller, Tungsten Carbide Seal

APPLICATIONS

INDUSTRIAL: Circulating and transferring, velocity-mixing, pumping machine tool coolants, spill return, sump drainage, chemicals, pharmaceuticals, soap, liquors, ink, dyes, alcohol, dilute acids, tanning liquors, glycerine, brine, etc.

PHARMACEUTICAL: Processing medicines, lotions and preparations. Filtering pharmaceutical solutions. Filling line supply pump.

Viton * is a trademark of E.I. Du Pont de Nemours and Company.



Models 30510-0XXX

PAPER PROCESSING: Transferring and applying starches, sizes, etc. Circulating and processing wood pulp slurries.

FOOD, BEVERAGE & DAIRY: Transfer brines, vinegar, syrups during processing, liquids containing solids in suspension such as chopped tomatoes, nuts, etc. Removal of distillery wort and brewery slop. Processing viscous materials such as peanut butter, mayonnaise, ketchup, honey, etc. (low speed). Pumping whiskey, wine, rums, juices and ciders.

AGRICULTURAL: Transferring liquid fertilizers, herbicides and pesticides.



Explosion hazard. Do not pump gasoline, solvents, thinners or other flammable liquids. To do so can cause an explosion resulting in injury or death.

OPERATING INSTRUCTIONS

- INSTALLATION** – Pump may be mounted in any position. The rotation of the pump shaft determines the location of the pump's intake and discharge ports (refer to dimensional drawing). Pump is normally assembled at factory for clockwise rotation (looking at end cover). If counter clockwise rotation is desired, follow steps 1 and 2 of disassembly and step 9 of assembly instructions to change direction of impeller blade deflection under cam.
- DRIVE** – Belt or direct with flexible coupling.
Belt Drive: Overtight belt load will reduce pump bearing life.
Direct Drive: Clearance should be left between drive shaft and pump shaft when installing coupling. Always mount and align pump and drive shaft before tightening the coupling set screw. If pulley or cou-



Injury hazard. Exposed pulleys and belts can cause injury. Install shield around pulleys and belts. Stay clear while machinery is operating.

pling must be pressed on shaft, remove end cover and impeller to support shaft from impeller end during press operation. Do not hammer pulley or coupling on shaft; this may damage bearing or seal.

Capacitor start motor is required to overcome starting torque of impeller.

3. SPEEDS – 100 RPM to the maximum shown in the performance curves. For longer pump life, operate at lowest possible speeds. Lower speeds are required for viscous liquids. Consult the factory for proper speeds and horsepower requirements.
4. SELF-PRIMING – Primes at low or high speeds. For vertical dry suction lift of 10 feet (neoprene/nitrile) – 4 feet (viton/EPDM), a minimum of 860 RPM is required. Pump will produce suction lift up to 22 feet when wet. BE SURE SUCTION LINES ARE AIR-TIGHT OR PUMP WILL NOT SELF-PRIME.
5. DISCHARGE – When transferring liquids further than 25 feet, use one size larger discharge line than discharge port size.
6. RUNNING DRY – Unit depends on liquids pumped for lubrication. DO NOT RUN DRY for more than 30 seconds. Lack of liquid will damage the impeller.
7. CHEMICAL COMPATIBILITY – Consult the Chemical Resistance Guide in the JABSCO Industrial Pump Catalog (available upon request from ITT Jabsco) or factory for proper body materials and impeller compounds. If corrosive fluids are handled, pump life will be prolonged if pump is flushed with a neutralizing solution after each use or after each work day. A Tungsten Carbide Seal variation is available for pumping liquids that contain abrasives or are highly corrosive.
8. PRESSURES – Consult Performance Curves for maximum recommended pressures for pumps in continuous operation. If pressures exceed those shown, consult the factory.
9. TEMPERATURES – The operating temperature limits of the pump depend on the impeller compound. The following ranges apply: Neoprene - 45° to 180° F (7° to 82° C), Nitrile - 50° to 180° F (10° to 82° C), Viton - 60° to 180°F (15° to 82°C), EPDM - 45° to 185°F (7° to 85°C).
10. IMPELLER TORQUE – The torque required to initiate rotation of a new impeller in a dry pump body is:
Standard Pressure Impeller (14281-Series):
Forward = 1.5 pounds force – feet
Reverse = 4.3 pounds force – feet
High Pressure Impeller (8980-Series):
Forward = 3.0 pounds force – feet
Reverse = 6.9 pounds force – feet
These values may vary slightly due to impeller compounding, blade set, and body material of construction. Consult factory for more information.
11. SPARE PARTS – To avoid costly shutdowns, keep a spare JABSCO impeller, seal and O-ring set on hand.

SERVICE INSTRUCTIONS

DISASSEMBLY

1. Remove the four end cover screws. Remove end cover and O-ring.
2. Remove the four screws holding the body to the bearing housing flange. Slide body, complete with impeller and wearplate, from pedestal and shaft assembly.
3. Remove mechanical seal by inserting two screwdrivers behind seal collar, and gently lever collar and seal assembly forward on shaft. Use extreme care not to mar shaft surface. Remove seal seat and rubber cup from recess in wearplate.
4. From the drive end of the bearing housing, pry out bearing seal by inserting a screwdriver blade between OD of the seal and housing. Remove retaining ring. Very carefully withdraw shaft and bearing assembly.
5. Remove inner bearing seal and retaining ring.
6. To remove bearings from shaft an arbor press is required. If an arbor press is not available then a bearing extractor may be used. Supporting inner race of bearing, apply a steady pressure on shaft until bearing slides free. Repeat this procedure to remove second bearing.

ASSEMBLY

1. To replace bearing on shaft. Support ball bearing on its inner race and locate shaft onto bearing. Apply a steady pressure to the shaft until bearing locates against shoulder on shaft. Repeat for second bearing.
2. Fit retaining ring and bearing seal into impeller end of bearing housing. Spring on bearing seal to face outwards.
3. Apply bearing grease around and between bearings, filling cavity between bearings two thirds full. Smear grease on shaft where bearing seal locates. Push shaft and bearing assembly into bearing housing.
4. Replace retaining ring and outer bearing seal with spring facing outwards.
5. Replace mechanical seal by sliding spacer onto shaft up to locating shoulder, then smear shaft with light lubricating oil. Push on seal gently until it engages with spacer. Fit rubber cup and seal seat into wearplate.
6. Insert impeller in pump body, fit O-ring in each end of the pump body. Fit wearplate to body.

NOTE: A gap should be maintained between bearing housing and body. DO NOT overtighten screws.

7. Slide wearplate and body assembly over shaft, position wearplate in housing. Fit body to pedestal with screws. Torque screws to 20 in. lbs.
8. Fit end cover and end cover screws. Torque screws to 20 in. lbs.
9. Changing Pump Rotation (looking at end cover):
Clockwise Rotation: Insert impeller into pump body with blades bending counterclockwise.
Counterclockwise Rotation: Insert impeller into pump body with blades bending clockwise.

EXPLODED VIEW

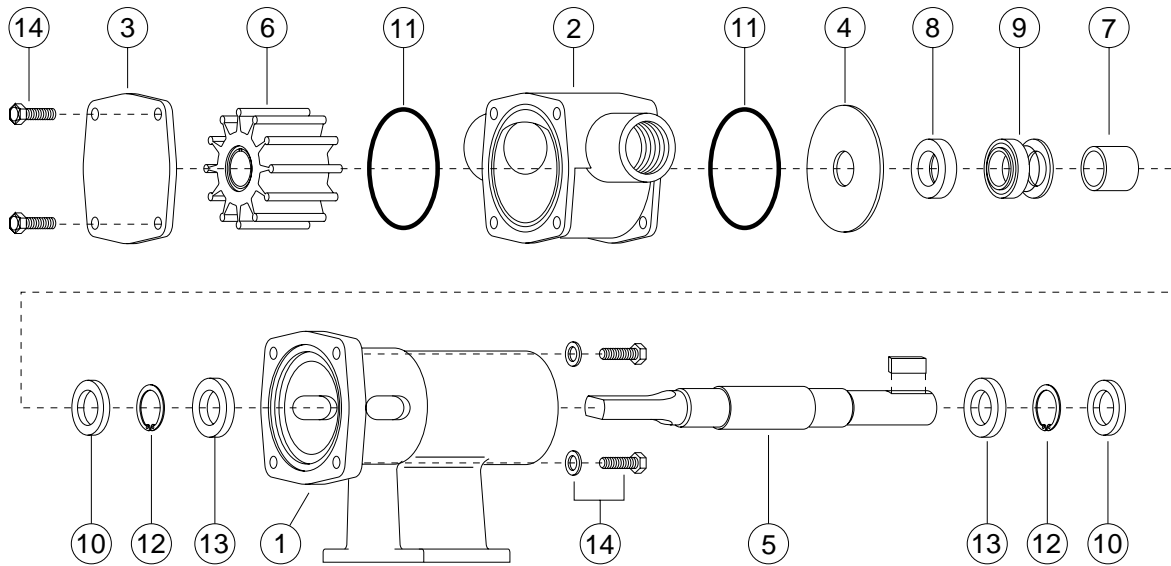

PARTS LIST

Key	Description	Qty. Req.	Part Number
1	Bearing Housing	1	18753-0183
2	Body	1	18753-0187
3	End Cover	1	18753-0193
4	Wearplate	1	18753-0199
5	Shaft	1	18753-0203
6	Impeller:	1	
	Standard Pressure – Neoprene		14281-0001
	Standard Pressure – Nitrile		14281-0003
	Standard Pressure – Viton		14281-0004
	Standard Pressure – EPDM		7614-0002
	High Pressure – Neoprene		8980-0005
	High Pressure – Nitrile		8980-0003
	High Pressure – Viton		8980-0004
	High Pressure – EPDM		8980-0002
7	Spacer:	1	18753-0221
8	Seal Seat:	1	
	Nitrile		18753-0233
	Ceramic		18753-0234
9	Seal Mech.:	1	
	Carbon – Nitrile		18753-0241
	Carbon – Viton		18753-0242
	Tungsten Carbide – Nitrile		18753-0243
	Tungsten Carbide – Viton		18753-0244
10	Bearing Seal	2	18753-0257
11	O-Ring:	2	
	Nitrile		18753-0261
	Viton		18753-0262
12	Retaining Ring	2	18753-0269
13	Bearing	2	18753-0273
14	Screw Kit:	1	18753-0277
	consists of		
	Screws, Hex Hd. M5 x 16mm (4)		
	Screws, Pan Hd. M5 x 16mm (4)		
	Washers, Flat M5 (4)		

DIMENSIONAL DRAWING
INCHES (MILLIMETRES)

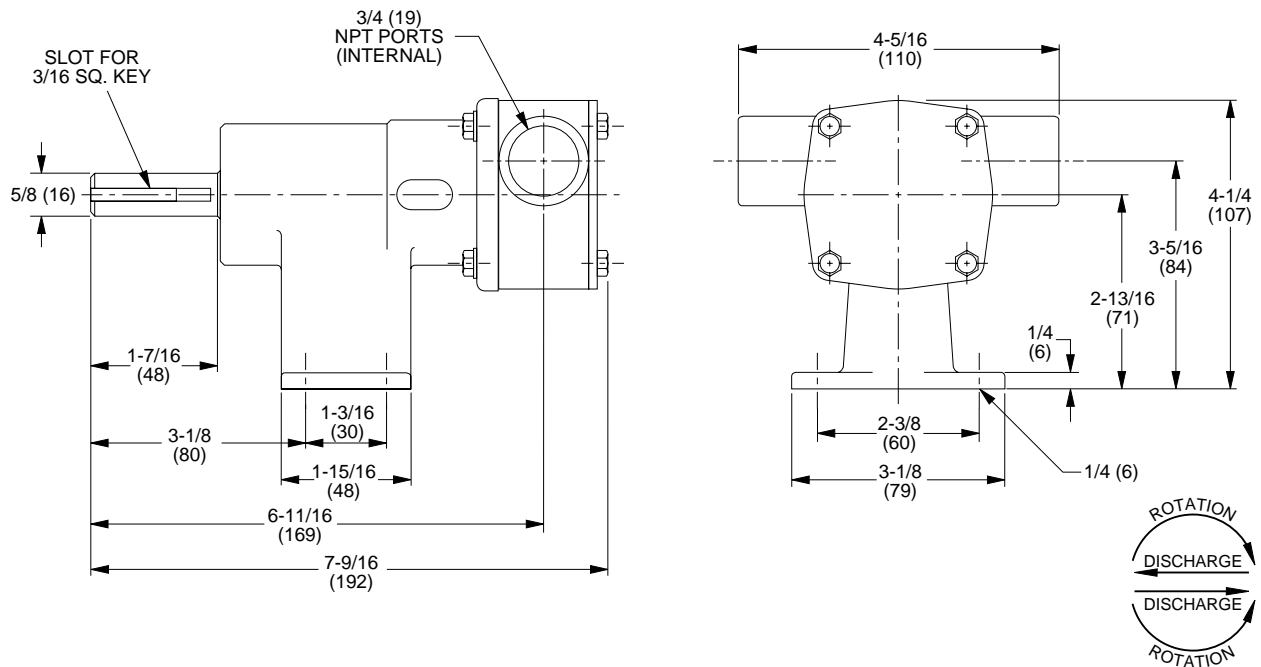

PERFORMANCE CURVES

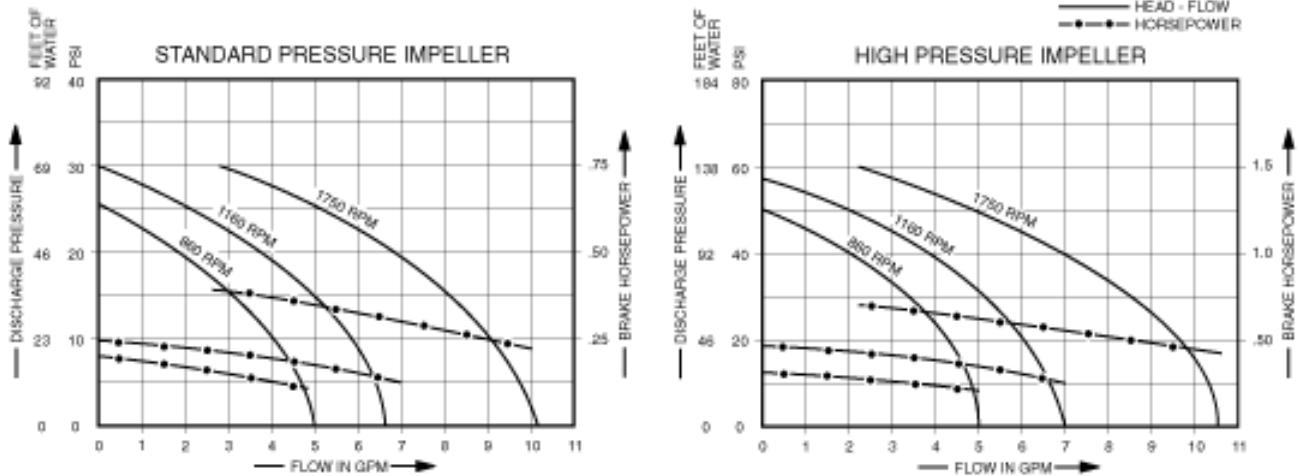

NOTE: Curves show approximate head-flow for new pumps with neoprene impeller pumping water.

Capacities should be reduced approximately 10% with nitrile standard pressure impellers and approximately 15% for high pressure viton and EPDM impellers.

Consult factory for specific performance information.

Jabsco



U.S.A.
Jabsco
20 Icon
Foothill Ranch, CA 92610-3000
Tel: (949) 609.5106
Fax: (949) 859.1254

UNITED KINGDOM
Jabsco
Bingley Road, Hoddesdon
Hertfordshire EN11 0BU
Tel: +44 (0) 1992 450145
Fax: +44 (0) 1992 467132

CANADA
Fluid Products Canada
55 Royal Road
Guelph, Ontario N1H 1T1
Tel: (519) 821-1900
Fax: (519) 821-2569

JAPAN
NHK Jabsco Company Ltd.
3-21-10, Shin-Yokohama
Kohoku-Ku, Yokohama, 222
Tel: 045-4758906
Fax: 045-475-8908

GERMANY
Jabsco GmbH
Oststrasse 28
22844 Norderstedt
Tel: +49-40-53 53 73 -0
Fax: +49-40-53 53 73 -11

THE PRODUCTS DESCRIBED HEREIN ARE SUBJECT TO THE JABSCO ONE YEAR LIMITED WARRANTY, WHICH IS AVAILABLE FOR YOUR INSPECTION UPON REQUEST.