

SUBMERSIBLE BILGE PUMP

FEATURES

- Strainer Base Protects Pump from Debris
- Exclusive Double Lip Seal Protects Motor from Moisture
- Anti-Airlock Pump Design to Clear Water Traps in Discharge Hose
- Electrically Isolated Motor Shaft Prevents Stray Current Leakage
- Meets A.B.Y.C. † Requirements
- Complies with USCG 183.410 and ISO 8846 MARINE for Ignition Protection
- Three year limited warranty
- Complies with ISO 8849
- CE

INSTALLATION

For maximum water evacuation, the pump should be located in the lowest point of the bilge. Determine the best location and pump position for ease of plumbing and direct routing of discharge hose. Mark the location of the strainer base, and position of base release tabs. Depress base release tabs and separate the strainer base from the pump housing.

The strainer base may be attached to the bilge with either small stainless steel sheet metal screws or a quality sealing compound with good adhesive characteristics such as Rule* Elastomeric Marine Sealant.

Use screws only if you are positive bottom thickness is greater than the depth of penetration of the screw. When drilling holes it is advisable to wrap a piece of tape around the drill bit so the edge of the tape marks the maximum hole depth required. Position base and align release tabs with position previously marked and mark position of the four mounting screw holes in the base. Very carefully drill four holes where marked and secure base to bottom with stainless steel screws. Do not crack base by over tightening screws. Snap the pump housing onto the base ensuring it is properly seated and latched in position.

A quality sealing compound may be used as an adhesive to secure the strainer base in the bilge. Ensure the area marked for mounting pump is thoroughly clean and free of oil residue. Apply a liberal circular bead of sealant on

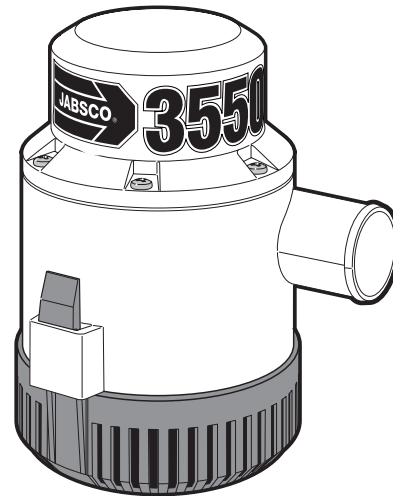

Model 30250-Series

bottom of strainer base and apply a dab of sealant to each screw hole in base. Press the base onto the bottom in the position marked, ensuring the base locking tabs align with their respective marked position.

Allow the sealant to cure in accordance with the manufacturer's instructions (generally 8 to 24 hours) then snap the pump housing onto the base, ensuring it is properly seated and latched in position.

A Jabsco RS-20 Float Switch can be attached directly to the side of the bilge pump by means of the switch mounting clip included with the 3550 pump. To do this, simply slide the adapter into the pump's strainer base until it snaps in place and then screw the switch to the adapter.

PLUMBING

Submersible Bilge Pumps must be plumbed to a thru-hull fitting that remains above the waterline at all angles of heel or trim (sailboats generally discharge through or below the transom). If installing a new discharge hose, the pump will operate at its greatest capacity if bends are kept to a minimum and the overall length is as short as possible. The Jabsco 3550 Pump has an anti-airlock design so a dip or water trap in the hose will be cleared automatically when the pump starts. In fact, it may be desirable to include a water trap in the discharge hose to prevent exhaust fumes from blowing into the vessel through the bilge discharge thru-hull and hose. Attach a 1-1/2" (38mm) hose to the pump port (and thru-hull fitting) with two stainless steel band clamps.

†A.B.Y.C. - American Boat & Yacht Council establishes standards for uniform and safe boat and yacht construction.

*Rule is a registered trademark of ITT Industries.

ELECTRICAL WIRING

⚠ WARNING



Fire Hazard. Failure to use proper size fuse can cause motor to overheat. Fire can result causing property damage, personal injury or death.

The Jabsco Submersible Pump may be wired for manual operation or for maximum security and versatility for both manual and automatic operation with the addition of a float switch. To ensure maximum performance, use a wire size large enough to carry the amperage required for the total length of the electrical circuit (see Electrical Specifications Chart). To comply with A.B.Y.C. Standards, the positive lead should be brown and

negative lead black. They should be supported with non-metallic clamps every 18" (45cm). When making wire connections use only mechanical locking connectors (crimp type or equivalent) and make all connections above the maximum bilge water level. Connections exposed to humid bilge environments may be sealed with silicone to prevent internal corrosion within the connector.

DIMENSIONS

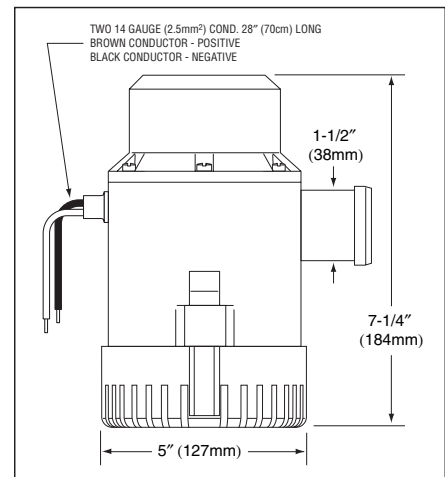

OPERATION

When installed in the lowest part of the bilge the Jabsco Submersible Pump will evacuate water down to a depth of about 5/8" (15mm). If wired for automatic operation, however, this depth may vary due to the shut off limit of the control switch.

The pump can run dry periodically without damage. However, for maximum seal life, the run dry periods should be kept to a minimum.

MAINTENANCE

Jabsco Submersible Pumps require no periodic maintenance other than occasionally checking and possibly cleaning the pump strainer base. To do this, simply depress the base release tabs and lift pump assembly from strainer base. Inspect the strainer base and pump inlet port and remove any debris which is present. Realign pump assembly with base and push down onto the base until it snaps securely in place. When inspecting pump for debris it is advisable to check the hose connections to ensure they are tight.

AUTOMATIC OPERATION

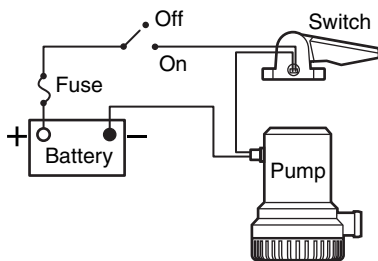

MANUAL / AUTOMATIC OPERATION

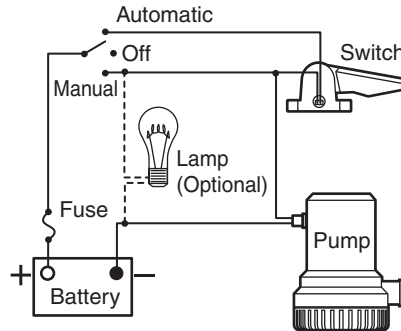

Model Number	Amp Volts	Fuse Draw	Fuse Size	Wire Gauges*			
				0'-20' (0-6m)	21'-40' (6.5-12m)	41'-60' (12.5-18m)	61'-100' (18.5-30m)
30250-2012	12	20	25	14 (2.5mm ²)	10 (6mm ²)	8 (10mm ²)	6 (16mm ²)
30250-2024	24	10	15	16 (1.5mm ²)	16 (1.5mm ²)	14 (2.5mm ²)	12 (4mm ²)

*Recommended wire size to allow no more than 10% drop in voltage. Length is the total of the circuit measured from the power source to the pump and back to ground.

PERFORMANCE CHART

Discharge Head - ft (M)	Flow Rate - GPH (LPH)
0 ft (0M)	3,550 (13,450)
3.4 ft (1M)	2,975 (11,300)
6.7 ft (2M)	2,400 (9,100)

Jabsco



ITT Industries

Engineered for life

U.S.A.
Jabsco
Cape Ann Industrial Park
Gloucester, MA 01930
Tel: 978.281.0440
Fax: 978.283.2619

UNITED KINGDOM
Jabsco
Bingley Road, Hoddesdon
Hertfordshire EN11 0BU
Tel: +44 (0) 1992 450145
Fax: +44 (0) 1992 467132

CANADA
Fluid Products Canada
55 Royal Road
Guelph, Ontario N1H 1T1
Tel: (519) 821.1900
Fax: (519) 821.2569

JAPAN
NHK Jabsco Company Ltd.
3-21-10, Shin-Yokohama
Kohoku-Ku, Yokohama, 222
Tel: 045.475.8906
Fax: 045.475.8908

GERMANY
Jabsco GmbH
Oststrasse 28
22840 Norderstedt
Tel: +49-40-53 43 73 -0
Fax: +49-40-53 53 73 -11

THE PRODUCTS DESCRIBED HEREIN ARE SUBJECT TO THE JABSCO THREE YEAR LIMITED WARRANTY, WHICH IS AVAILABLE FOR YOUR INSPECTION UPON REQUEST.