



**Model 18685-0000**

## 115V AC ROTARY VANE PUMP

### FEATURES

- Body:** Bronze
- Rotor:** Vectra\*
- Vanes:** Ryton\*\*
- Seal:** Lip Type, Nitrile
- Motor:** 1/8hp - 115V AC, 60Hz TENV, 3450 RPM
- Protection:** Thermal Overload
- Cord:** 6' Cord with 3 Prong Grounded Plug
- Ports:** 1/2 (13mm) NPT Female  
1" (25mm) Hose Barb
- Weight:** 14-1/2 lbs (6.5 kg)



**Model 18685-0000**

<b>⚠ WARNING</b>	<b>Explosion hazard. Do not use where flammable vapors are present. Do not pump gasoline, solvents, thinners or other flammable liquids. To do so can cause an explosion resulting in injury or death.</b>
------------------	--

### APPLICATION

The Jabsco rotary vane pump is ideal for pumping light oil or transferring diesel fuel. The rotor and vanes are not affected by petroleum products. It is dry, self-priming with a suction lift of up to five feet and can pump against a discharge head of up to twenty feet. The motor is rated for continuous duty in applications with a total system head no greater than twenty feet and when pumping liquids with a similar viscosity to diesel fuel. When pumping light oils, the duty cycle should be no longer than thirty minutes.

### INSTALLATION

The 115V AC vane pump can be used as a portable pump or mounted permanently in pumping system. It can be mounted on any flat surface. However, it is advisable to mount it so the motor shaft remains horizontal. The pump head may be rotated on the motor 180° to accommodate plumbing connections as needed or to change the direction of flow.

### PLUMBING CONNECTIONS

Pump ports have external 1" hose barb and 1/2" NPT Female threads. Use hose that does not kink when bent and with sufficient wall thickness to prevent collapse when used on suction side of pump. Hoses should be routed so that some fluid will be retained in pump body to wet the rotor and vanes.

Wetting the rotor and vanes aids in priming. Use a strainer on the intake hose if trash or solids are present in the fluid being pumped. Diesel fuel and used oil may contain debris or contaminants which require the use of a fine mesh screen strainer. **ALL HOSES MUST HAVE AIR-TIGHT CONNECTIONS TO ENABLE FAST PRIMING.**

### PERFORMANCE DATA

PSI	TOTAL HEAD		CAPACITY	
	Feet	Metres	GPM	LPM
2.1	5	1.5	7.9	29.9
4.3	10	3.0	7.8	29.5
8.7	20	6.1	6.9	26.1

Table shows approximate Head-Flow for new pump pumping diesel fuel. If pumping water, flow rates are reduced approximately 20%.

**NOTICE:** Do not exceed above performance parameters or pump damage may occur.

\* Vectra is a registered trademark of Celanese Corporation

\*\* Ryton is a registered trademark of Phillips Chemical Company

## OPERATION

### WARNING



**Explosion hazard. Do not pump volatile liquids with a flash point below 100°F (38°C). Doing so can cause an explosion or fire resulting in injury or death.**

Rotary Vane pumps must NOT be run dry, as the pumped liquid is the lubricant for the rotor and vanes. Observe the outlet and shut off pump as soon as liquid stops flowing.

The pump cannot run against a closed outlet as encountered when using a garden hose type shut-off nozzle. Pressure for normal operation should not exceed 20 feet of head (8.7 psi). Excessive pressures will cause motor to overheat tripping the thermal overload protector.

Temperature of pumped liquid may range from 45°-165°F (7°-74°C). When pumping engine oil, run engine long enough to heat oil to about 150°F (66°C).

NOTE: Diesel fuel has a flash point of 100°-190° F (43°-88°C).

## DISASSEMBLY

1. Remove end cover screws, end cover and O-ring.
2. Withdraw rotor and vanes.
3. Loosen and remove two slotted hex screws, which attach body to motor.
4. Tap body lightly between ports and remove body from motor.
5. Press seal from the rotor side of the body out of the seal bore.

## ASSEMBLY

1. Press seal from the motor side of the body into the seal bore with lip pointing toward the rotor bore.
2. Lubricate motor shaft and install body on motor.
3. Aligning flat in rotor with flat on motor shaft, install rotor. Install vanes in vane slots of rotor.
4. Install O-ring, end cover and end cover screws.

## MAINTENANCE

Periodic cleaning of rotor and vanes will ensure proper pump performance and extend life.

Periodic cleaning of the inlet strainer, rotor and vanes will extend pump life. For best performance replace vanes and rotor every 250-500 hours. In freezing conditions, loosen end cover screws to drain fluid from pump head.

## EXPLODED VIEW

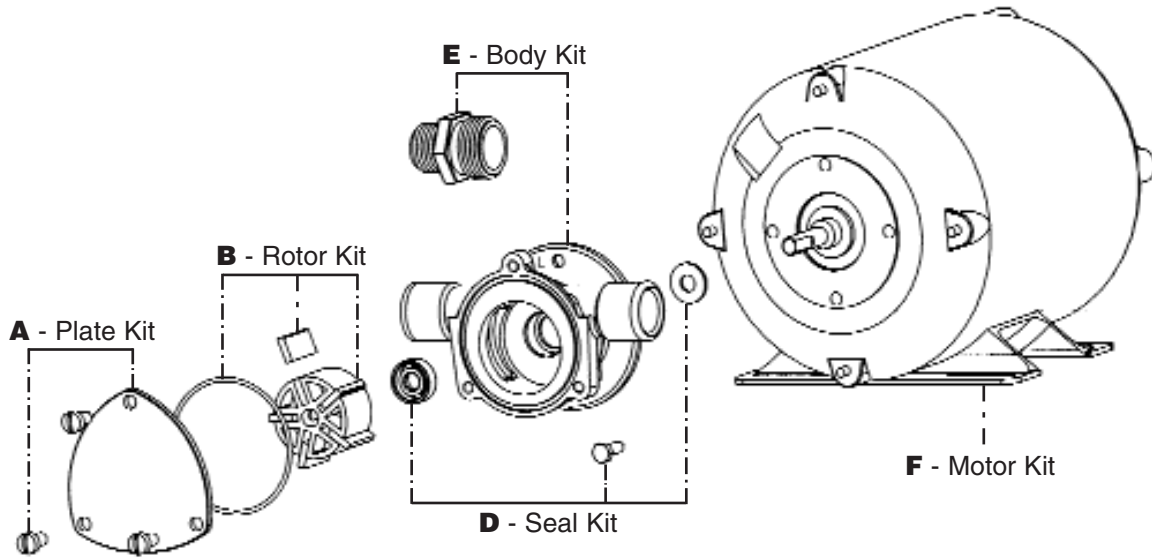

## PARTS LIST

KIT	DESCRIPTION	KIT NUMBER
A	End Cover Screw Kit End Cover	18647-1000
*H	O-Ring (set of 50)	18753-8660
B	Vanes (set of 5) Rotor	18753-2073
D	Sea I- Nitrile Screw (Pump to motor) Slinger	18753-4384
E	Body 3/4" Male Garden Hose Adapter	18644-5000
F	Motor	18753-0082

## REPLACEMENT PART KITS

JABSCO RECOMMENDS THAT ALL COMPONENTS IN EACH INDIVIDUAL KIT BE REPLACED AS A MATTER OF GENERAL MAINTENANCE.

\* O-Ring gasket contained in kits A, B & D.

**DIMENSIONAL DRAWING**  
**Inches (Millimetres)**

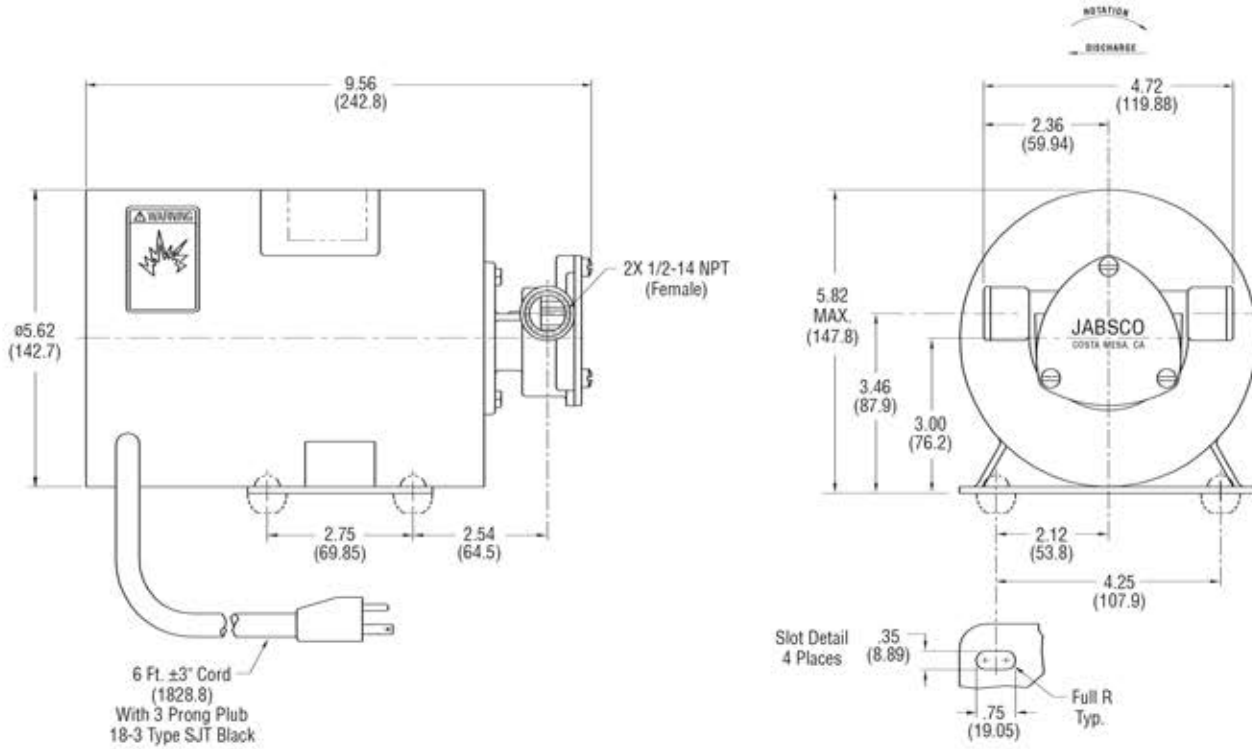

**Jabsco**

THE PRODUCTS DESCRIBED HEREIN ARE SUBJECT TO THE JABSCO ONE YEAR LIMITED WARRANTY, WHICH IS AVAILABLE FOR YOUR INSPECTION UPON REQUEST.

**U.S.A.**  
 Jabsco  
 20 Icon,  
 Foothill Ranch, CA 92610-3000  
 Tel: (949) 609.5106  
 Fax: (949) 859.1254

**UNITED KINGDOM**  
 Jabsco  
 Bingley Road, Hoddesdon  
 Hertfordshire EN11 0BU  
 Tel: +44 (0) 1992 450145  
 Fax: +44 (0) 1992 467132

**CANADA**  
 Fluid Products Canada  
 55 Royal Road  
 Guelph, Ontario N1H 1T1  
 Tel: (519) 821.1900  
 Fax: (519) 821.2569

**JAPAN**  
 NHK Jabsco Company Ltd.  
 3-21-10, Shin-Yokohama  
 Kohoku-Ku, Yokohama, 222  
 Tel: 045.475.8906  
 Fax: 045.475.8908

**GERMANY**  
 Jabsco GmbH  
 Oststrasse 28  
 22840 Norderstedt  
 Tel: +49-40-53 43 73 -0  
 Fax: +49-40-53 53 73 -11