

# Technically the Best

## Hy~Line Super Sanitary Positive Displacement Rotary Pumps

### Design Features

- Most Stringent Sanitary Standards**  
 Flush rotor fixing screws are sealed to prevent product ingress. Contoured rotor case internals for full drainability during SIP and shaft seals set up front where the pumping action is! Fully conforming to 3A Sanitary Standards and utilizing materials which meet FDA requirements. Versions are available that have been tested and approved to the EHEDG (European Hygienic Equipment Design Group), CIP and SIP protocols.
- Low Maintenance Costs**  
 Front loaded single shaft seals are fully accessible from the front of the pump without disturbing the process pipework. Simple bearing assemblies easily pre-set using automotive technology. Bi-wing rotors require no timing adjustments. Even the pump casing is removable, a feature not normally associated with other bi-wing rotor pumps.
- High Volumetric Efficiency**  
 The bi-wing rotors incorporate the low viscosity efficiency associated with circumferential piston pumps with the viscous product handling capability of tri-, quad- and bi-lobe rotor pumps..... at an affordable price!
- Rugged Design**  
 Hy~Line design utilizes extremely large shaft diameters mounted in high specification taper roller bearings, fitted into an extremely rigid central pillar made from a high grade alloy. This is all enclosed in an oil filled housing made from the same alloy. These ensure maximum shaft stiffness and together with wide tipped rotor wings, which adds another dimension to security, avoid premature pump failure due to overpressure or other abuse.

### Options

- Seals**  
**Front loaded single mechanical face type seals** of hygienic design. Materials include carbon, stainless steel and silicon carbide.  
  
**Low pressure flushed seals** utilize the same single mechanical seal with an additional housing. A low pressure flush liquid washes away crystallizing products or liquids which 'skin over'.  
  
**Double mechanical seals** utilizing all the components from single seals. Used for hazardous, toxic, highly abrasive or sterile products.  
  
**Front loaded single O-Ring seals** - a low cost seal option used primarily for self lubricating products and products which contain little or no abrasives.  
  
**Front loaded double O-Ring seals** - suitable for pressurized grease or flushing with a suitable liquid to enable low cost sealing of high sugar confectionery and bakery products.
- Multiple PTFE lip seal** - complete with controlled release food grade grease injection system, the ideal sealing system for chocolate and other products sensitive to water flush.
- Connections**  
 All US and European standards including Tri-Clamp and Bevel Seat and NPT. All pumps available with 2 different sizes, all fully interchangeable.
- Elastomers**  
 Buna N, Viton, EPDM and PTFE product contact joints available in compounds conforming to 3A Sanitary Standard 02-09 and FDA title 21 section 177.2600.
- Other options**  
 Pump Head temperature control jackets.  
 Integral pressure relief valve.  
 Enlarged suction port for viscous products.  
 All stainless steel bearing pedestal and cover.  
 Low carbon 316L pump head.

	Hy~Line										
Pump Model	LH32	LH34	LH42	LH44	LH52	LH54	LH62	LH64	LH72	LH74	LH76
Port Size (inch)	3/4 or 1	1 or 1 1/2	1 or 1 1/2	1 1/2 or 2	1 1/2 or 2	2 or 3	2, 2 1/2 or 3	3 or 4	3 or 4	4 or 6	5 or 6
Displacement gall/100 rev	0.9	1.8	3.2	5.4	7	12	16.8	25	32.5	54.2	80
Maximum Flow US GPM	13.7	27.7	32	54	67	115	121	180	221	325	478
Maximum Pressure psi	215	115	215	115	215	115	215	115	215	115	72
Maximum Speed (RPM)	1500	1500	1000	1000	1000	1000	720	720	680	600	600
Dimensions LxBxH inches	8x7.5x6.5	9x7.5x6.5	11x9x8	11x9x8	15x10x10	15x10x10	17x11x12	18x12x12	19x15x14	21x15x14	22x16x14
Weight (bareshaft) lbs	18	22	40	44	71	77	134	143	275	319	364
Temperature °F	-22 to 284										
Viscosity cP	1 to 1 million										

### Construction Details

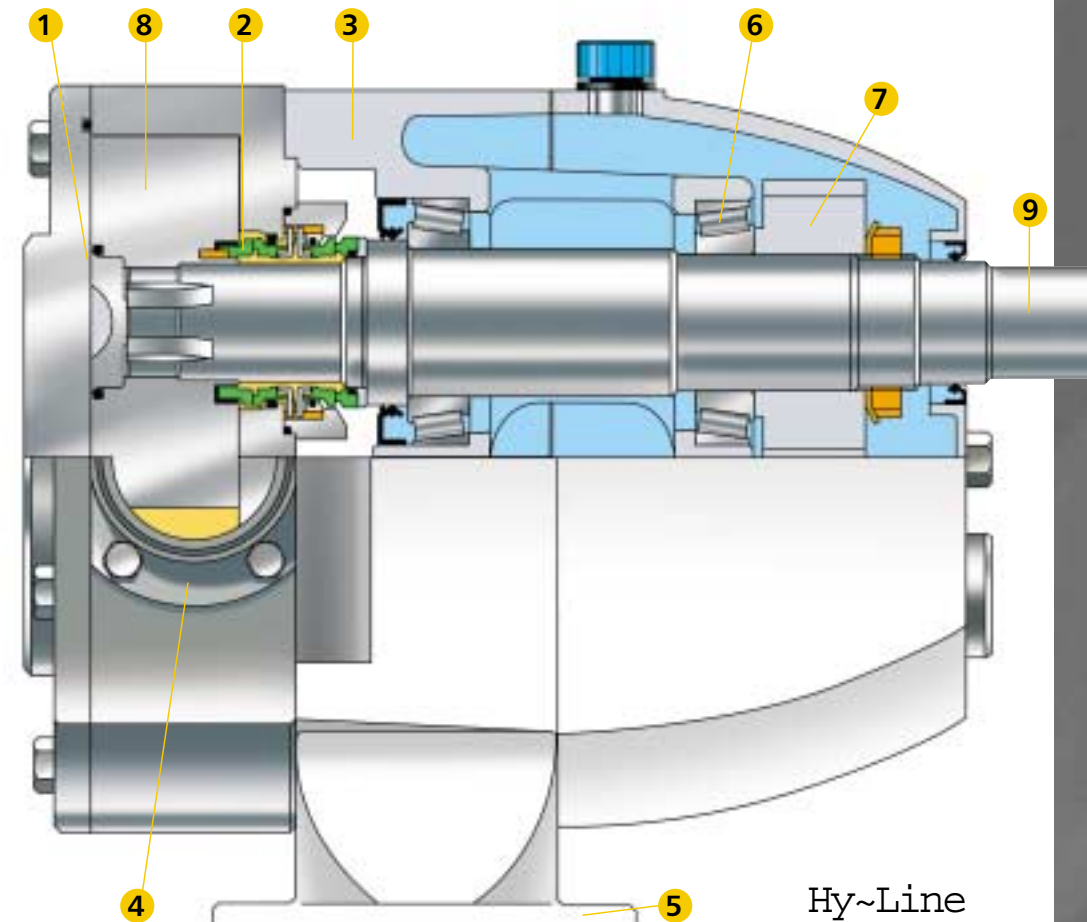

- Flush fitting, sealed rotor retaining screws avoid build up of stagnant product as no end cover recesses are required and no product can get into the rotor drive.
- Front mounted shaft seals for easy replacement and full accessibility of CIP liquids.
- Rugged, high grade alloy bearing pedestal and housing for low weight and high strength, completely encased in epoxy coating.
- Most sizes have detachable ports for maximum flexibility in connection type.
- Removable feet allow quick change for pump mounting in the ideal orientation.
- High spec taper roller bearings give over one million hours life on a typical duty.
- Most sizes have precision cut spur gears for high load capability and ease of maintenance.
- Fully interchangeable bi-wing rotors can be fitted without the need to re-time thus reducing downtime and allows pump to cope with a higher level of abuse.
- Heavy duty shafts for high pressure capability.

Hy~Line



Jabscos latest rotary positive displacement pump incorporates the very latest in sanitary design concepts in order to fulfill the ever increasing customer demands for improved cleanability, sanitation and sterilizability. This 316 stainless steel design uses a bi-wing rotor, which encompasses the very best features of tri-lobe rotor pumps and circumferential piston pumps. The pump is built upon Jabscos 40 year experience of producing and supplying their Pureflo flexible impeller and 24 Series rotary lobe pumps to the world's most demanding markets.