



***IWAKI AMERICA  
MAGNETIC DRIVE PUMP  
WMD-100 SERIES  
INSTRUCTION MANUAL***



Thank you for having selected an Iwaki America WMD-100 Series magnetic drive pump. This instruction manual deals with the correct handling, maintenance, inspection, and troubleshooting procedures for the WMD-100 magnetic drive pump. Please read through it carefully to ensure the optimum performance, safety and long service of your pump.

## Contents

Item	Page
1 Unpacking and Inspection.....	1
2 Identification.....	1
3 Specifications.....	2
4 Handling.....	2
5 Installation and Operation.....	3
6 Assembly.....	4
7 Maintenance and Inspection.....	5
8 Parts Description and Exploded View .....	6
9 External Dimensions and Weight .....	7

# 1 Unpacking and Inspection

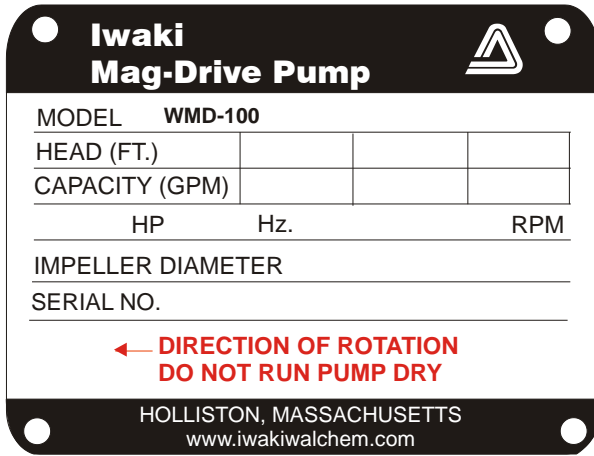

Open the package and check that the product conforms to your order. Also, check each of the following points. For any problem or inconsistency, contact your distributor at once.

1. Check that the model number indicated on the nameplate conforms to the specifications of your order.
2. Check that all the accessories you ordered are included.
3. Check that the pump body and parts have not been accidentally damaged or that any bolts have not been loosened in transit.

# 2 Model Identification Guide

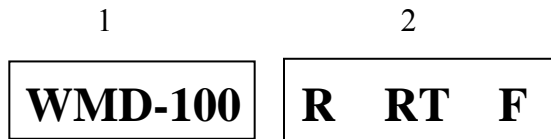

1. Series name
2. Materials of construction

	R	RT	F
Materials	Glass fiber reinforced polypropylene (GFRPP)		Carbon fiber reinforced fluoroplastic
Connections	Hose 1" I.D. conn.	1" NPT male	
Bearings	Alumina Ceramic/Rulon		Silicon Carbide
O-ring	FKM (Viton)		

### 3 Specifications

	WMD-100R(T)	WMD-100FY	WMD-100FZ
Specific gravity limit	1.2	1.3*	1.9*
Max capacity gpm (L/min)	36 (136)	36 (136)	28 (106)
Max head ft (m)	41.5 (12.6)	38 (11.6)	27 (8)
Motor output hp (kw)	1/3 (.25)		

Notes:

1. Fluid temperature range: 32-176°F (0-80°C)
2. \*Limit of specific gravity at maximum flow when fluid viscosity is 1 CP. Specific gravity fluids up to 2.2 can be handled with appropriate trimming of impeller. Consult factory for recommended trim.

### 4 Handling Instructions

#### 1. Do not operate the pump dry.

The sliding parts used in the WMD-100 series pump are lubricated and cooled by the fluid being pumped. Never operate the pump dry or with the valves on the suction side closed. Otherwise, the inside of the pump will be damaged. If the pump is unavoidably or accidentally operated dry, with no obvious damage, allow the pump to cool down for a minimum of one hour before attempting to restart. Do not allow fluid to enter the pump cavity until the pump has cooled down. Sudden or rapid cooling of the pump may cause damage to the bearing system. A dry run operation device is recommended for the prevention of dry pump operation.

#### 2. Starting

Prior to starting the pump, make sure that the power is turned off. Then carry out priming to fill the pump cavity with liquid.

Next, close the valves on the discharge side. Now you can turn the power on and start up the pump. When the pump has reached full speed and line pressure is stable, the discharge valves can be opened to the desired settings.

#### 3. Stopping

When stopping the pump, first close the discharge valve gradually. When it is completely closed, turn off the power switch so that the pump stops. Never stop the pump suddenly by quickly closing a valve (i.e., solenoid or hydraulic valves).



Caution

Quick valve closure may cause water hammer which can cause severe damage to the pump.

4. Maximum system pressure rating is 31.0 PSI (2.2 kgf/cm<sup>2</sup>).

5. Influence of temperature.

The pump itself may not suffer a change in performance due to temperature fluctuation. However, the liquid may change in terms of viscosity, vapor pressure, and corrosive properties. Pay special attention to changes in liquid characteristics as a result of temperature fluctuation.

Liquid temperature range: 32 - 176°F (0-80°C)

Ambient temperature range: 32 - 104°F (0 - 40°C)

## 5 Installation and Operation

---

---

### ■ Installation

1. Secure the pump to floor or platform by bolting down the motor using all holes provided.
2. Check power source for proper voltage and phase. Plug the pump powercord into a switched, grounded outlet or hardwire into a properly grounded circuit. Use appropriate wiring materials and abide by all local and national electrical codes.
3. Connect the inlet and outlet fittings of the pump with appropriate size tubing or pipe connections.
  - A. For tubing connections use standard hose clamps to secure tubing. ***DO NOT OVER TIGHTEN.***
  - B. For pipe thread connections, use pipe tape to insure a good seal. ***DO NOT OVER TIGHTEN.***
  - C. For convenient disconnection of pumps installed with rigid pipe, install unions near both inlet and outlet connections.

### ■ Operation

- A. If the pump is to be left idle for extended periods, flush the pump with water to prevent crystallization of the fluid inside the pump chamber.
- B. If the fluid to be pumped contains suspended solids, install a strainer in the suction plumbing, periodically inspect the suction strainer and remove any built-up debris.

- C. Fluids of high specific gravity CANNOT be pumped. See pump specifications for more information.
- D. The impeller may decouple from the drive magnet for several reasons: e.g. temperature, viscosity or specific gravity are too high. This is usually indicated by initial pumping, then a complete cut off of flow. Turn off power to the motor, allow it to stop rotating, then start it again. If the problem recurs, check for excess temperature, viscosity, or specific gravity.

## 6 Assembly

---

### ■ Liquid End Mounting Instructions (for pumps supplied without motor)

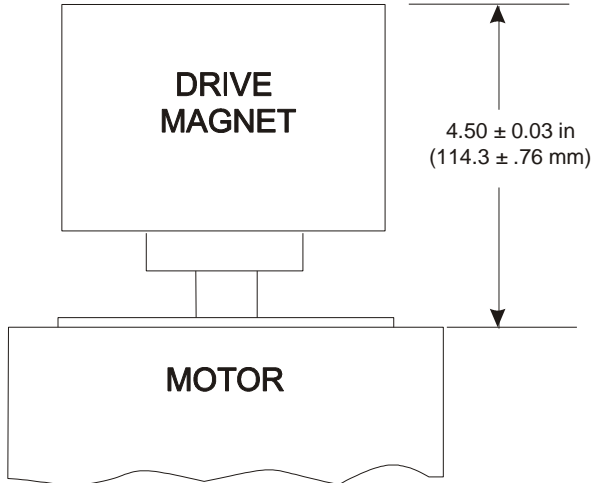

1. Place the motor on end vertically so that shaft is pointed upward.
2. Apply Loctite (or equivalent) to the two set screws on the drive magnet. Install drive magnet on motor shaft and position face of drive magnet 4.50 inches above the "C-Face" of the motor. Align the drive magnet so that the screws avoid the keyway of the shaft. Tighten the two set screws of the magnet using a 3mm allen wrench.
3. Place the pump adapter bracket on motor "C-Face" mating the motor face to the bracket recess. Position the bracket so that the drive magnet access hole is aligned with the motor base. Fasten the bracket to motor using four 3/8 "-16 x 3/4" hex head socket bolts with 3/8" flat and lock washers.
4. Insert impeller/magnet capsule into rear casing. Seat o-ring in groove of rear casing. Place front casing over rear casing making sure that the o-ring is properly secured. Slide the retainer ring over the outside of the rear casing until it seats properly in the flanged section of the rear casing. Align the liquid end over the bracket so that the discharge port is pointed at 12:00 o'clock when viewed from the suction port.

Using a hex head driver, fasten the liquid end to the bracket using six #10-24 screws, with flat and spring washers, torque to 485 oz-in (35 kgf-cm).

■ **Magnet Capsule/Impeller Installation (for WMD-100F pumps only)**

1. The magnet capsule/impeller (wrapped in bubble pack) will be found in the same box that the pump was shipped in. It was removed to protect the silicon carbide ceramic bearing components from damage during shipment.
2. To install the magnet capsule/impeller, remove the six Phillips head screws on the front casing of the pump. Be careful not to lose the small flat and lock washers.
3. Remove the front casing, noting its original orientation and install the magnet capsule/impeller into the rear casing.
4. Install and align the front casing, ensuring that the o-ring is still seated properly, and retighten the six screws. Be sure to utilize the flat and lock washers. Torque front casing bolts to 485 oz-in (35 kgf-cm).

## 7 Maintenance and Inspection

---

■ **Daily Inspection**

1. Check that the pump operates smoothly, without generating abnormal sounds or vibration.
2. Check the level of the liquid in the suction tank, and the suction pressure.
3. Compare the discharge pressure and current measured during operation with the specifications indicated on the motor and pump nameplate to verify normal pump load.

\* Note that the indicated value of the pressure gauge varies in proportion to the specific gravity of the liquid.

\* Note that the valve of the pressure gauge or vacuum gauge should be opened only when measurements are recorded. It must be closed after completion of each measurement. If the valve remains open during operation, the gauge mechanism may be affected by abnormal pressure caused by water hammer.

## 8 Parts Description and Exploded View

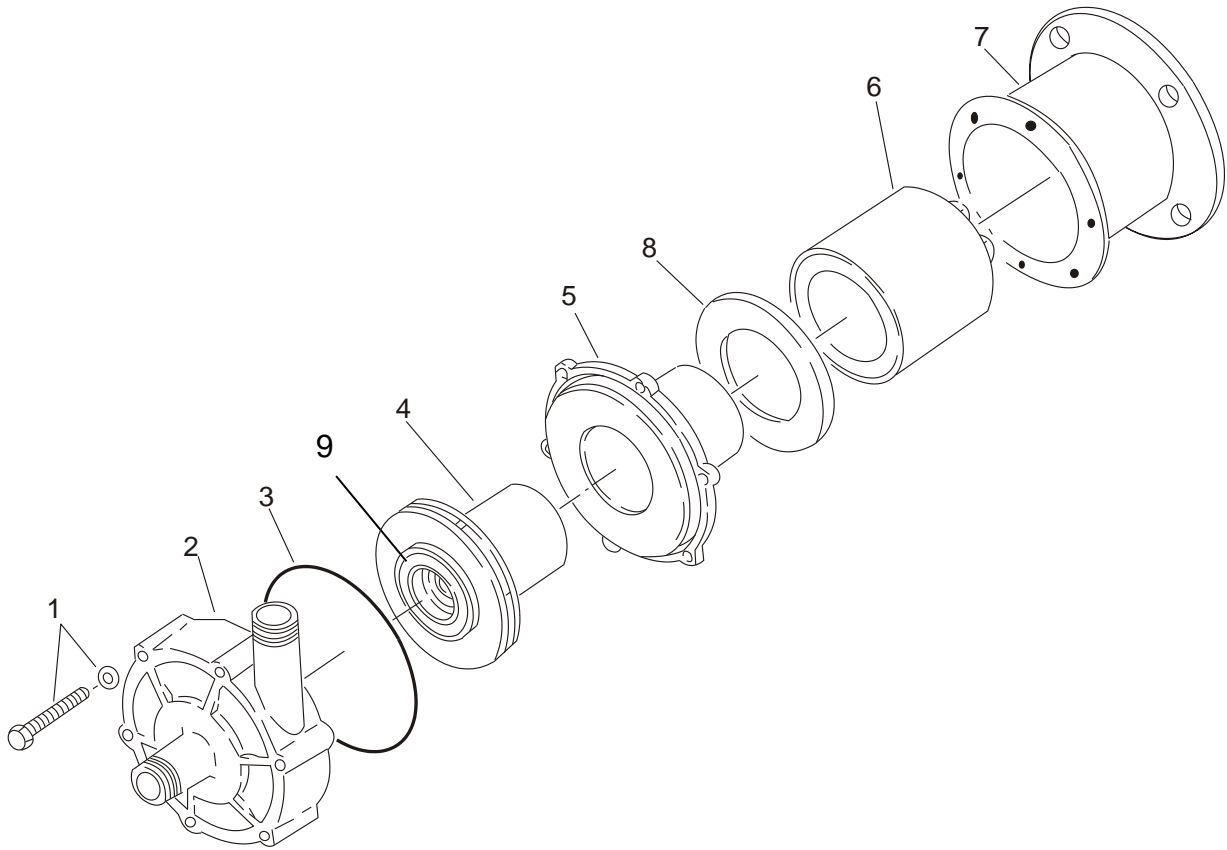

Item No.	Description	Item No.	Description
1	Screw	5	Rear casing
2	Front casing	6	Drive magnet
3	O-ring	7	Adapter bracket
4	Impeller	8	Retainer
		9	Mouth ring*

\* GFRPP version only



## 9 Dimensions and Weights

### WMD-100R

Pump end weight - 6 lbs (2.7 kg)

Note: WMD-100RT & WMD-100FY/FZ  
have 1" NPT-M suction and discharge ports.

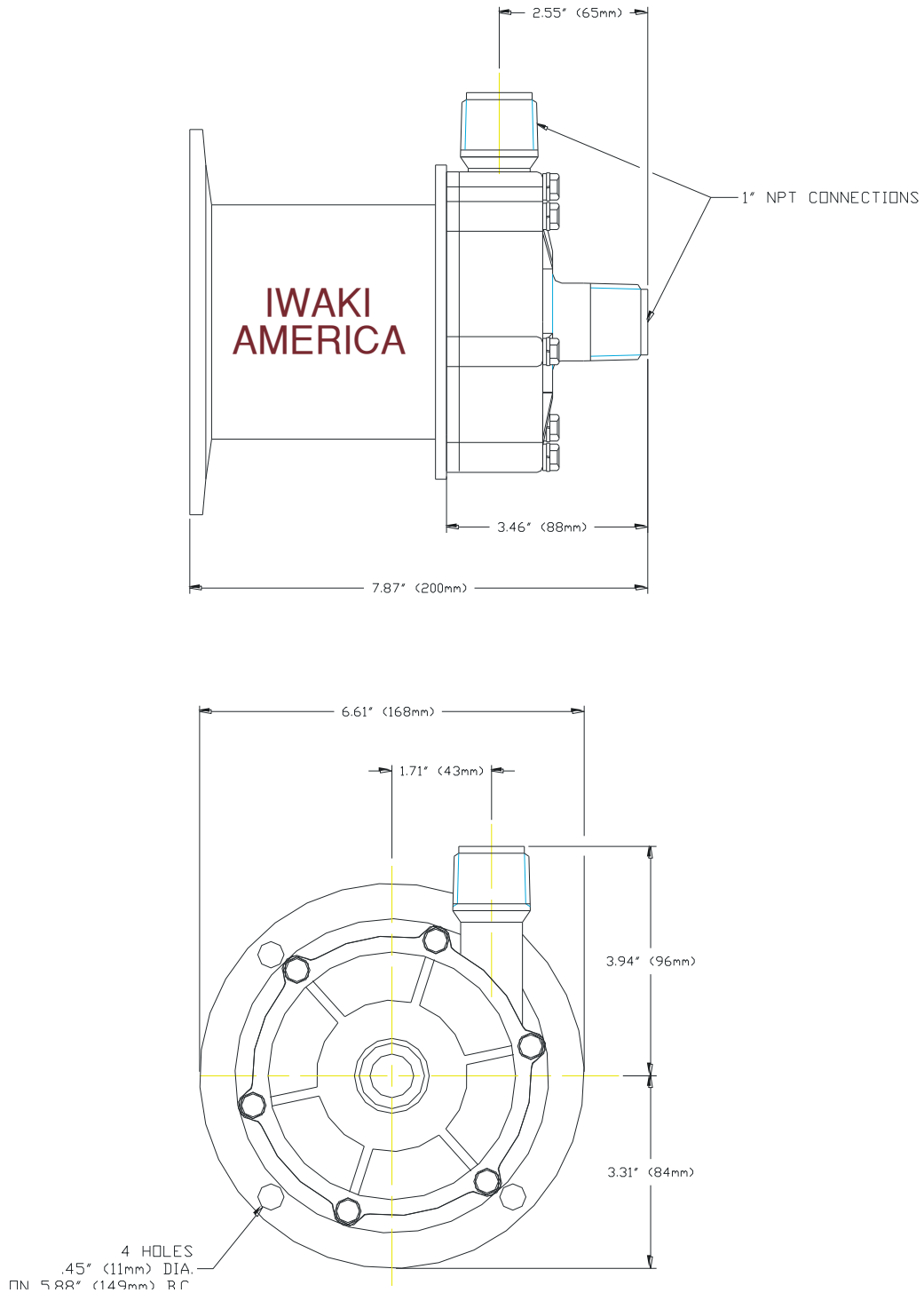

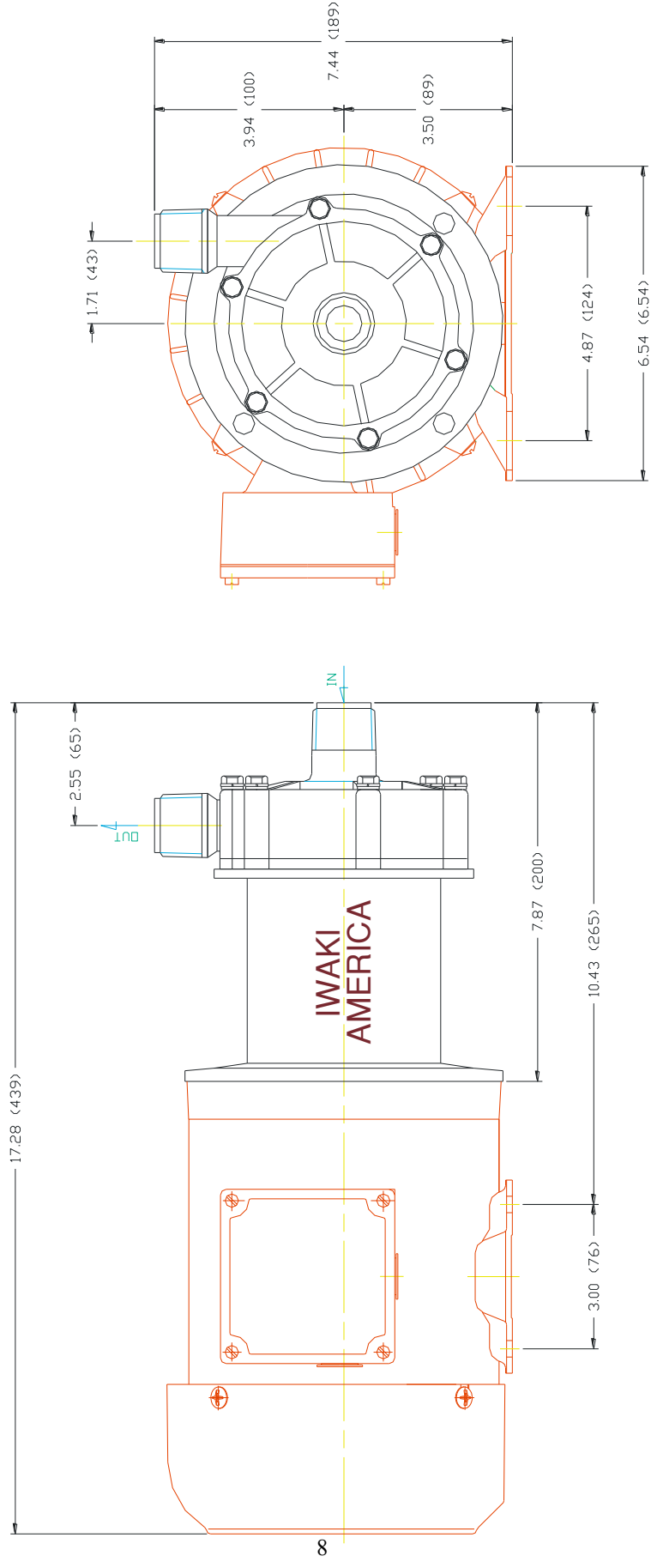

Notes:

1. Ref. Dimensions will vary with motor manufacturer.
2. Dimensions are in inches (mm).
3. Pump weight = 28 lbs (w/factory motor)

---

5 BOYNTON ROAD HOPPING BROOK PARK HOLLISTON, MA 01746 USA  
TEL: 508-429-1440 FAX: 508-429-1386 [www.iwakiamerica.com](http://www.iwakiamerica.com)