



HYPRO®

**POWERLINE® PLUS
2000 PLUNGER PUMPS**

Form L-0500PL
Rev. B

Installation, Operation, Repair and Parts Manual

Description

PowerLine Plus 2000 plunger pumps are designed for pumping water, soap, detergent, and other nonflammable liquids that are compatible with pump component materials. The maximum liquid temperature is 160° F for the PowerLine Plus 2200B-P, 2300B-P and 2400B-P model pumps.

Construction features include an oil-bath crankcase, a forged brass head, polished ceramic plungers and stainless steel unitized valves, (high-temperature, preloaded cup seals). Car wash pumps include high performance, low pressure seals for superior reliability in high vacuum applications. Heavy-duty, high pressure seals and back-up washers are included in all car wash

pumps to guard against corrosion and continuous duty fatigue.

The 2200B-P and 2300B-P series have sturdy connecting rods/floating wrist pins (patent-pending). The crankshafts on all models are made of forged steel that is supported by extra heavy-duty bearings. The shaft rotation is in either direction.

Special corrosion-resistant cartridges are included specifically for car wash applications. Hypro's user-friendly oil-seal replacement cartridge technology on the 2200B-P, 2300B-P, 2350B-P, 2400B-P and 2430B-P models minimizes downtime.

CARTRIDGE TECHNOLOGY

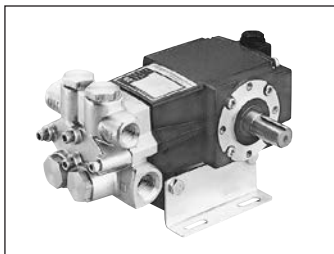

**POWERLINE PLUS
2200B-P**

Duplex Plunger Pump

Flow Rate: 2.1 to 3.0 gpm
Max. Pressure:
2000 psi (1725 rpm)
1500 psi (3450 rpm)
RPM: 1725 & 3450 rpm
Ports: 1/2" inlet
3/8" outlet
Shaft: 3/4" dia. (solid)
5/8" dia. (hollow)
3/4" dia. (hollow)



**POWERLINE PLUS
2300B-P and 2350B-P**

Triplex Plunger Pump

Flow Rate: 3.1 to 4.8 gpm
Max. Pressure:
2500 psi (2300)
3000 psi (2350)
RPM: 1725 rpm
Ports: 1/2" inlet
3/8" outlet
Shaft: 3/4" dia. (solid)
3/4" dia. (hollow)



**POWERLINE PLUS
2303B-P, 2304B-P & 2314B-P**

Triplex Plunger Pump

Flow Rate: 3.1 to 4.2 gpm
Max. Pressure:
1200 psi
RPM: 1725 rpm
(2303B-P & 2304B-P)
1450/1100
(2314B-P)
Ports: 1/2" inlet
3/8" outlet
Shaft: 3/4" dia. (solid)

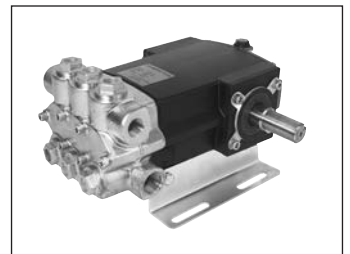

**POWERLINE PLUS
2400B-P and 2430B-P**

Triplex Plunger Pump

Flow Rate: 4.3 to 7.9 gpm
Max. Pressure:
2500 psi (2400)
3600 psi (2430)
RPM: 1725 rpm
Ports: 3/4" inlet
1/2" outlet
Shaft: 1" dia. (solid)

Drive Source Installation

This manual covers the installation of the basic drive configurations available for Hypro's PowerLine Plus 2000 plunger pumps. Adapter kits, flange kits, and gearbox kits are covered in the installation instructions packed with the

kit. Consult the recommendations of the manufacturer of your motor or engine for additional information. Read all safety information before attempting to install or operate the pump.

General Safety Information

⚠ California Proposition 65 Warning -- This product and related accessories contain chemicals known to the State of California to cause cancer, birth defects or other reproductive harm.

- WARNING: Use a pressure relief device on the discharge side of the pump to prevent damage from pressure buildup when the pump discharge is blocked or otherwise closed and the power source is still running. For trigger gun operation, or where discharge is frequently shut off, pressure unloader valves are recommended. FAILURE TO FOLLOW THIS WARNING CAN RESULT IN PERSONAL INJURY AND/OR PROPERTY DAMAGE AND WILL VOID THE PRODUCT WARRANTY.**
- WARNING: Do not pump flammable or explosive fluids such as gasoline, fuel oil, kerosene, etc. Do not use in explosive atmospheres. The pump should be used only with liquids that are compatible with the pump component materials. Failure to follow this warning can result in personal injury and/or property damage and will void the product warranty.**
- Do not run the pump faster than maximum recommended speed.
- Do not pump at pressures higher than the maximum recommended pressure.
- The maximum liquid temperature is 160°F for PowerLine Plus 2200B-P, 2300B-P and 2400B-P models.
- Make certain that the power source conforms to the requirements of your equipment.
- Provide adequate protection in guarding around the moving parts such as the shaft and pulleys.
- Disconnect the power before servicing.
- Release all pressure within the system before servicing any component.
- Drain all liquids from the system before servicing any component.
- Secure the discharge lines before starting the pump. An unsecured line may whip, causing personal injury and/or property damage.
- Check the hose for weak or worn condition before each use. Make certain that all connections are tight and secure.
- Periodically inspect the pump and the system components. Perform routine maintenance as required. (See Maintenance section.)

WARNING: RISK OF ELECTRIC SHOCK!

To reduce the risk of electric shock, adequately ground the electric motor to a grounded metal raceway system, or use a separate grounding wire that is connected to bare metal on the motor frame or to the grounding screw located inside motor terminal box; or ground by other suitable means. Refer to the most recent National Electric Code (NEC) Article 250 (Grounding) for additional information. **ALL WIRING SHOULD BE PERFORMED BY A QUALIFIED ELECTRICIAN.**

WARNING: Do not handle a pump or pump motor with wet hands or when standing on a wet/damp surface or in water.

- Do not operate a gasoline engine in an enclosed area. Be sure the area is well ventilated.

WARNING: Gasoline is a highly combustible fuel. The improper use, handling, or storage of gasoline can be dangerous. Never touch or fill a hot engine.

- Use only pipe, hose and fittings rated for the maximum psi rating of the pump. If an unloader is used, then the pipe should be rated for pressure at which the unloader operates.
- Do not use these pumps for pumping water or other liquids for human or animal consumption.

Direct Drive - Flexible Coupling Installation

To order the correct shaft couplers for your pump model, refer to Hypro Price List PL01.

- Insert the keys onto the shafts and slide the coupler ends onto the pump and motor shafts flush with the shaft end.
- Mount the motor and pump onto the bases — shimming the pump or motor so that the shafts are aligned. Make sure the shafts are aligned parallel. Leave enough space between the ends of the shaft to allow the coupler center disc to be inserted.
- When the alignment is made, slide the coupler ends together over the coupler center disc.
- Securely tighten the set screws in both coupler ends.

CAUTION: For safety, install a shield over rotating shafts and couplers.

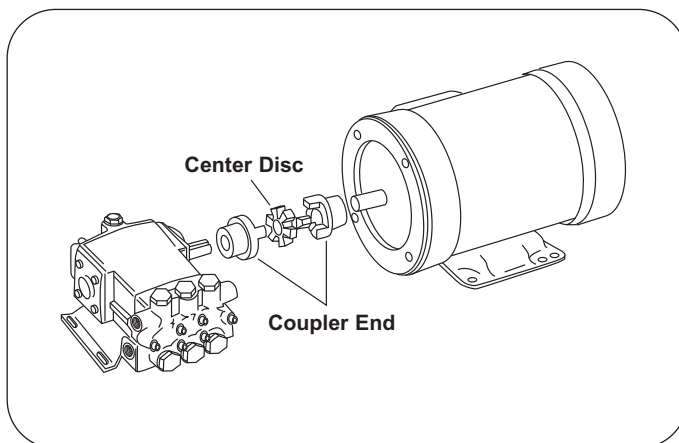

Belt/Pulley Drive Installation

Belt and pulley drive systems are typically used to reduce pump speed. Pumps may be rotated in either direction allowing either clockwise (CW) or counter-clockwise (CCW) operation of the motor or engine.

For determining proper pulley sizes, use the formula below as a guideline and use "A" or "B" section belts.

$$\frac{\text{MOTOR RPM}}{\text{PUMP RPM}} = \frac{\text{FLOW (@RATED SPEED)}}{\text{FLOW (DESIRED)}} = \frac{\text{PUMP PULLEY DIA.}}{\text{MOTOR PULLEY DIA.}}$$

EXAMPLE: Use a 1725 rpm electric motor to drive a pump at 950 rpm.

Typically, a pulley diameter on the motor is 3.4 inches. The pump pulley diameter can be determined from the formula above:

$$\frac{1725}{950} = \frac{\text{PUMP PULLEY DIAMETER}}{3.4 \text{ INCHES}}$$

$$\frac{1725 \times 3.4 \text{ INCHES}}{950} = 6.2 \text{ INCHES}$$

1. Install the pulley or bushing/sheave combination (See Figure 1) onto the pump and motor shaft. Mount the pump next to the motor making sure the pulleys are lined up properly. Use a straightedge as shown in Figure 2. Rotate to check for run-out and bent shafts.
2. Install belt(s) and use slots in the pump mounting rails to tighten the belts. Make sure the belts have proper tension. Belts that are too tight will cause bearing wear, and belts that are too loose will cause slipping. (See Figure 3.)

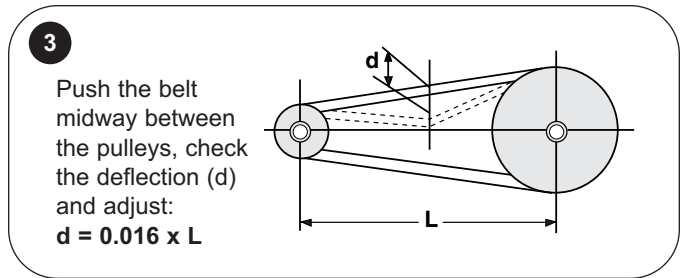
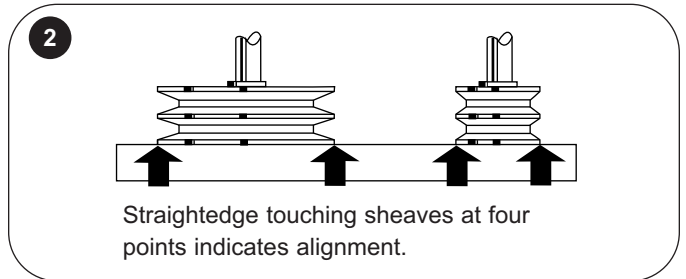
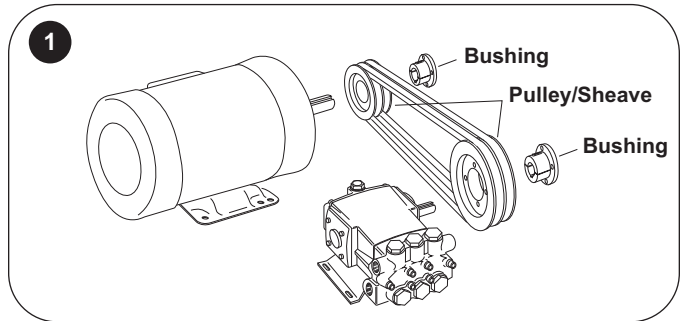

Direct Drive - Hollow Shaft and Integral C-Flange Installation

1. Position and mount the motor onto the base.
2. For hollow shaft models, install rubber grommets into the pump base, and install the pump base onto the pump securing with two 5/16" x 1/2" bolts.
3. Insert the key into the motor shaft keyway. Apply Never-Seize to the shaft and key.
4. Slide the pump onto the motor shaft. **DO NOT FORCE**; this prevents binding.
5. For integral C-flange models, line up the holes in the flange with the holes in the motor face and secure with four 3/8" x 7/8" hex head bolts.
6. Install set screws into the pump shaft and tighten securely.

Note: For hollow shaft models, the pump should not be mounted rigidly but should rest on the rubber grommets in the base to prevent rotation of the pump.

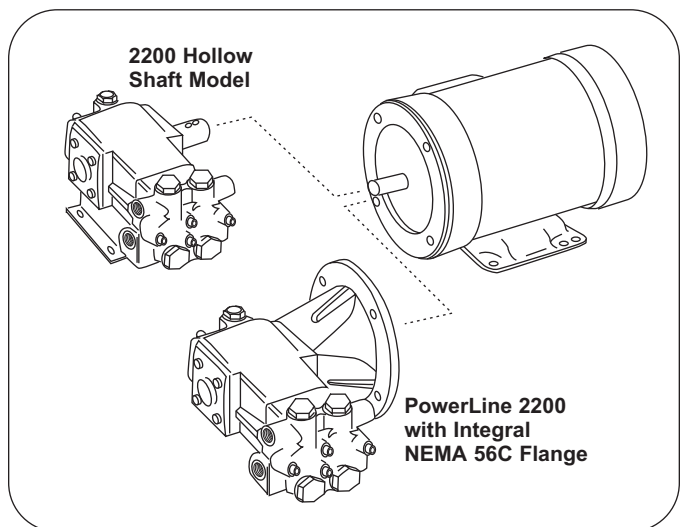

System Installation

1. In general, select an adequate size drive unit to avoid overloading. Avoid unnecessary restrictions in the line such as elbows, check valves, and all extraneous curves and bends.
2. Avoid using a looped section which might permit air to become trapped.
3. Use pipe joint sealant on the pipe threads to assure airtight connections.
4. **Selection of the right type and size of hose is vital to good performance. Be sure to hook the lines to the proper ports on the pump.**
5. Always use genuine suction hose of at least the same diameter as the inlet port of the pump. If the suction (inlet) hose is more than four feet long, use the next larger size.
6. A strainer should be installed in the suction line (80 to 100 mesh is recommended). Clean the strainer as soon as it becomes clogged.
7. Use one or two braid reinforced hose to prevent collapse of suction line.
8. Use only approved, high-pressure hose on the discharge side, and make sure all connections are tight.

NOTE: Use only pipe, fittings, accessories, hose, etc. rated for the maximum pressure rating of the pump.

Pump

1. Before installing the pump, clean all fittings and hoses.
2. Rotate the pump by hand to make sure it turns freely.
3. Make sure that all hose connections are tight and use the proper size fittings that are capable of safe operation.

CAUTION: Replace the oil plug with the dipstick before operating the pump.

IMPORTANT: Hypro PowerLine Plus pumps are filled with Hypro Oil. Hypro recommends changing oil after 40 hours of break-in operation and every three months or 500 hours, whichever comes first. Use Hypro Oil (P/N 2160-0038). Refer to the recommended lubrication marked on the crankcase of the pump.

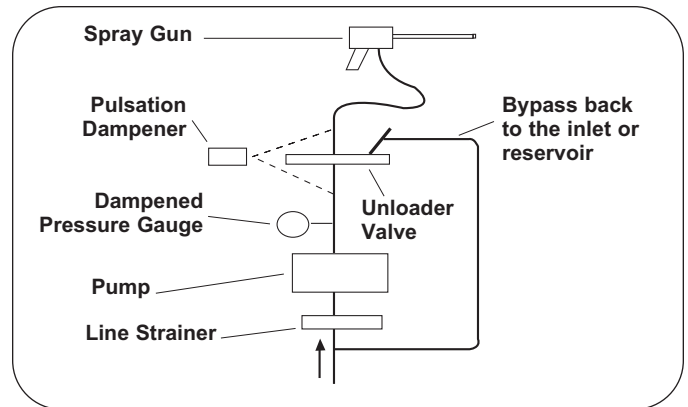

Discharge Side Installation

From the pump to the discharge hose, the following accessories are recommended: a dampened pressure gauge with a face pressure double the maximum operating pressure, an unloader valve, a pulsation damper, an optional pressure gauge to monitor unloader, and discharge hose.

Accessories such as an unloader valve, a pressure gauge, a pulsation dampener - should be installed as close to the pump as possible. A hose must be used right after the accessories. If solid piping is used, a two to four foot section of hose must be installed between the accessories and the piping.

Inlet Side Installation

From the source of liquid to the pump, the following components are recommended: a shut-off valve, a bypass return tee from the unloader, a line strainer, and a compound pressure gauge.

Inlet Water Supply

Inlet Filter: Should be an 80-mesh screen.

Hose: Pressure feed, 3/4" I.D. garden hose.

Feed Requirement: 5 gpm — open.

A garden hose should supply 10 gpm minimum (twice the pump requirement).

Operation

WARNING: DO NOT pump flammable or explosive liquids such as gasoline, kerosene, etc. DO NOT pump corrosive or abrasive liquids because these will cause rapid wear or deterioration of plungers, valves and seals in the pump. The pump should be used only with liquids compatible with pump component materials. Do not exceed the maximum specified rpm and pressure. Observe the lubrication instructions. Failure to follow this warning will void the product warranty.

Lubrication

Before running the pump, check the oil level using the dipstick. Refer to the recommended lubrication marked on the crankcase of the pump.

The crankcase capacity is as follows:

PowerLine Plus 2200B-P: 8 fl. oz., SAE 100 weight non-detergent; PowerLine Plus 2300B-P/2350B-P: 14 fl. oz., SAE 100 weight non-detergent; PowerLine Plus 2400B-P/2430B-P: 26 fl. oz., SAE 30 weight non-detergent.

Change oil every 500 hours of operation.

Priming the Pump

To prime the pump, adjust the unloader valve to its lowest pressure setting. After starting the pump, open and close the gun to aid priming and to clear the valves of air. If the pump does not prime within a few seconds, stop the motor and inspect the installation for suction line leaks and obstructions. In general, keep suction lift to a minimum and avoid unnecessary bends in the suction line. The unloader valve must be readjusted after the prime has been obtained.

Care of the Pump

Generally, after each use, flush the pump with a neutralizing solution for the liquid pumped. Follow with a clear water rinse. For storage under freezing conditions, flush the pump with a 50% mixture of automotive antifreeze and water.

Repair Instructions

Plunger Seal Repair

Models 2200B-P, 2300B-P and 2350B-P

Tools Required

- 3/16" Allen Wrench
- External Pliers (P/N 3010-0057)

1. Replace the plunger seals if there is water leakage from the weep hole (Figure 1).
2. Use a 3/16" Allen wrench to remove the cylinder head bolts. Remove the head from the crankcase assembly (Figure 2).
3. After removing the head, rotate the shaft and remove the cup retainers from the plungers (Figure 3).
4. Remove the cup retainer and the cup from the cylinder head. If they can't be removed by hand, use an external pliers (Figure 4).
5. Replace the plunger seal kits. Refer to the parts lists for the proper kit for your pump model.
6. Install the parts as follows:
 - a. With the groove facing down into the cylinder head, install the high pressure cup (Figure 6, Ref. A).
 - b. Install the Teflon support ring over the cup (Ref. B).
 - c. Install the plunger seal kits into the head as shown in Ref. C.
7. Turn the crankshaft so the plungers are even. With the outlet valve plugs up, install the cylinder head onto the crankcase body (Figure 7).
8. The capscrews should be torqued at 105-115 in. lbs. If a torque wrench is not available, tighten the capscrews down, but do not over tighten. Use a rotating procedure as shown (Figure 8). Remember to include the lock washers under the capscrews.

Valve Assembly Replacement - ALL Models

1. Remove the valve cap (Figure 9, Ref. 1).
2. With a needle nose pliers, remove the valve assembly (Ref. 3) from the head.
3. Remove the o-ring (Ref. 4) from below the valve assembly.
4. Remove the o-ring (Ref. 2) from the valve cap.
5. To reassemble, reverse the above steps.
6. Torque specifications on the valve cap:
60 ft. lbs. on the 2200B-P and 2300B-P series.

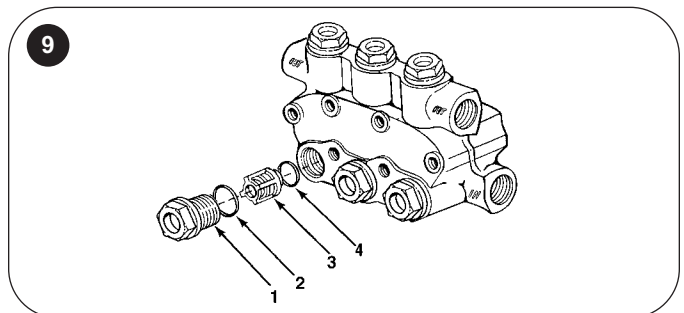
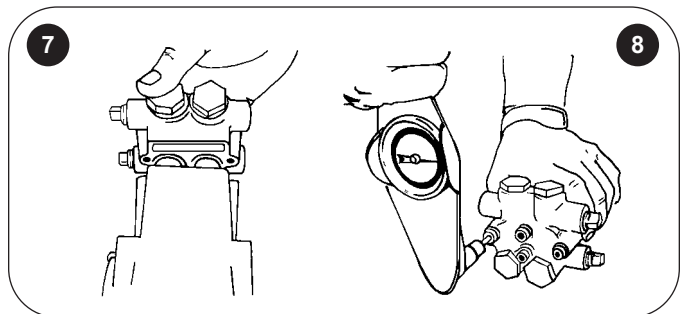
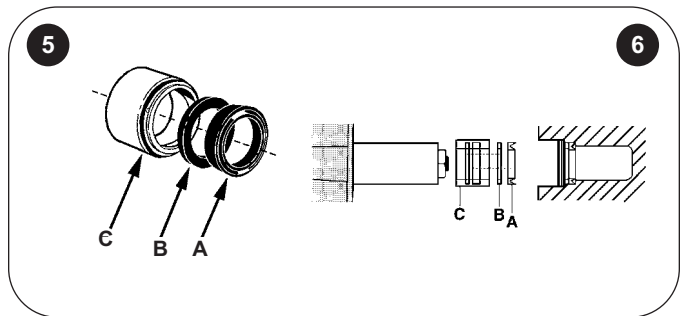
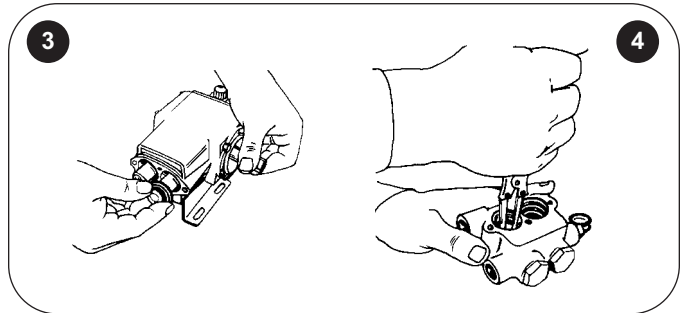
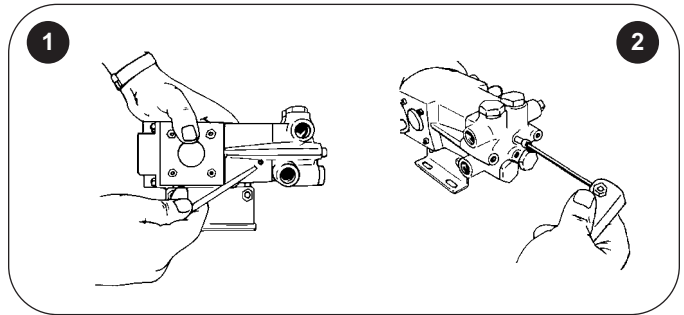

**Packing Replacement
Models 2400B-P and 2430B-P**

1. With a 1/4" Allen wrench, remove six head bolts. Turn the shaft to push the head from the crankcase assembly, then pull the head off the plungers.
2. Remove the cup retainer assembly from the cylinder head. These can usually be removed with a finger. If they cannot be removed by hand, use an external pliers to remove the assemblies from the head (Figure 1). (It may be helpful to place a screwdriver between the pliers jaws.)

Next, remove the Teflon backup ring and the high pressure cup from the head.

3. Remove the low pressure seal from the cup retainer with a small flat-blade screwdriver. The o-ring around the outside of the cup retainer can also be removed with a small screwdriver or knife.
4. Remove the vacuum rings by rotating the crankshaft. Remove the retainers from the oil seal retainer.
5. If you are replacing oil seals at this time, see the oil seal replacement section.
6. The parts to be replaced consist of three high pressure cups, three backup rings, three low pressure cups, three vacuum seal rings and six o-rings found in the seal repair kit. Refer to the parts list for the proper parts kit. The parts shown in Figure 2 are as follows:

(a) high pressure cup, (b) backup ring, (c) brass cup retainer, (d) low pressure cup, (e) low pressure cup retainer, (f) vacuum seal ring, (g) vacuum o-ring, (h) o-ring, vacuum seal retainer, (i) vacuum seal retainer.

7. Install the parts into the head as follows: (Figures 2 and 3)
 - 7.1 Install the high pressure cup with the groove facing down into the cylinder head.
 - 7.2 Install the backup ring over the high pressure cup.
 - 7.3 Install the brass cup retainer with the narrow end facing down into the cylinder head.
 - 7.4 Install the low pressure cup into the cup retainer.
 - 7.5 Install the low pressure cup retainer into the head.
 - 7.6 Press the vacuum seal ring into the o-ring. With the two parts together, push them into the vacuum seal retainer.
 - 7.7 Place the o-ring (h) over vacuum seal retainer.
 - 7.8 Install the vacuum seal with the retainer and retainer ring, over the plunger and into the oil seal retainer.
8. Install the cylinder head onto the plungers with the outlet ports on top. Secure to the crankcase with the head bolts torqued to 170 inch lbs. (Figure 4).
9. Turn the pump shaft to make sure there is no binding.

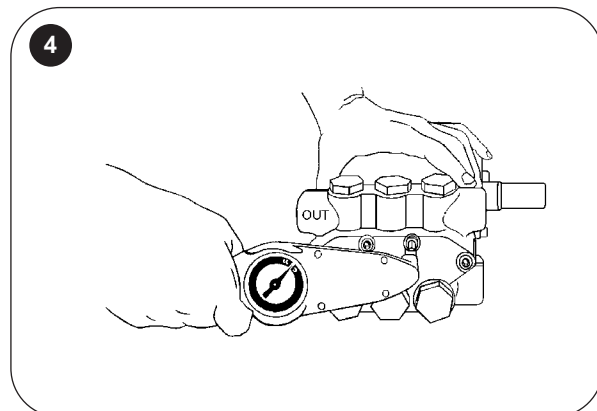
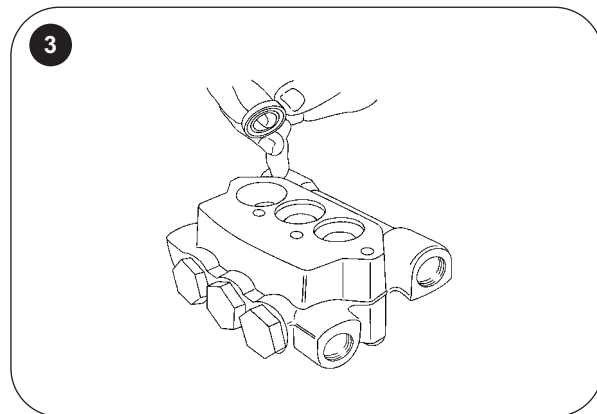
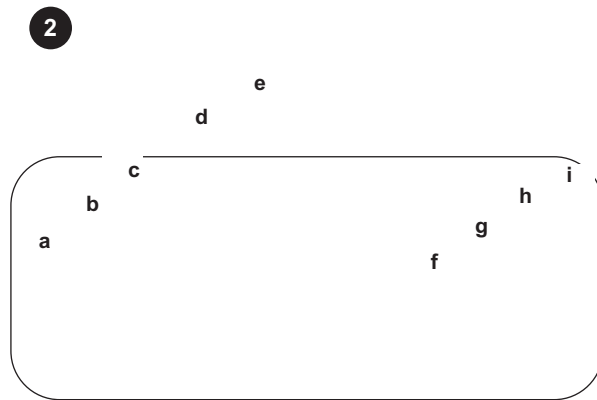
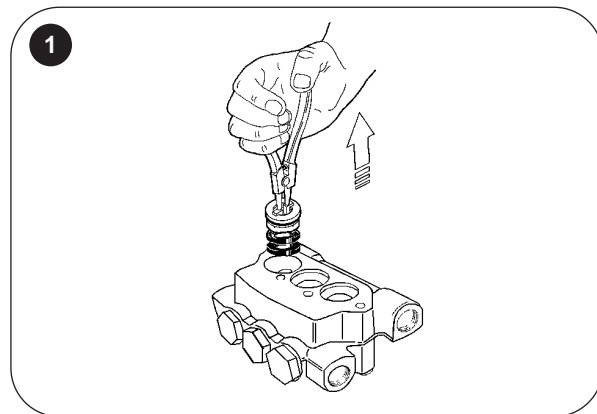

Oil Seal Replacement 2200B-P and 2300B-P Series

Tools Required

- Oil seal insertion tool P/N 3010-0248
(Models 2200B-P thru 2350B-P)
- 9/16" hex wrench
- 3/16" flat screwdrivers

1. Drain the oil from the crankcase using a 9/16" hex wrench (Figure 1).
2. Remove the cylinder head, then remove the plunger retaining nuts with a 9/16" hex wrench. Remove the plungers and slinger rings (Figure 2).
3. Inspect the plunger rods for nicks or scratches. Turn the crankshaft, and at the same time, note the condition of the rods (Figure 3). Replace the rods if nicks or scratches are present. The oil seal will not work if the plunger rods are damaged. (Remove the back cover to replace plunger rods). CAUTION: The needle bearings have loose needles. Repack the needles with grease to hold in place if the shaft is removed.
4. Lift out the plunger guide using two flat screwdrivers. Be careful not to damage the plunger rods (Figure 4).
5. Replace the plunger guides with oil seals and o-rings by indexing to the vent ports as shown (Figure 5). Refer to the parts list for the proper oil seal repair kit for your model of pump.
6. Reinstall the slinger rings and ceramic plungers (Figure 6); torque the retaining nut to 105-115 in. lbs. Use Loctite 242 on all plungers and nuts. Reinstall the cylinder head. Check to see that the crankshaft turns freely.
7. Install the oil plug. Fill the crankcase to the correct oil level on the dipstick. Refer to the recommended lubrication marked on the crankcase of the pump. Use 8 oz. for 2200 models; 14 oz. for 2300 models.

Oil Seal Replacement Series 2400B-P and 2430B-P

1. See the packing replacement instructions for head removal.
2. Remove the plunger nut, plunger and slinger ring.
3. Lift the oil seal retainer cartridge from the crankcase. A 90° Allen wrench or bent bar may be used to pry the retainer out. The slot under each plunger may be used to access the cartridge (Figure 8).
4. Push the old oil seal out and remove the o-ring from the outside of the cartridge.
5. Install the new oil seal into the cartridge placing the flat surface in first. Replace the o-ring on the outside of the cartridge. Lightly oil the o-ring and cartridge to prevent damage during installation.
6. Push the retainer containing the o-ring and oil seal into the crankcase. Align the holes in the cartridge with the slots in the crankcase.
7. Replace the plunger as described in the plunger replacement section. Replace the head as described in Step 8 of the packing replacement section.

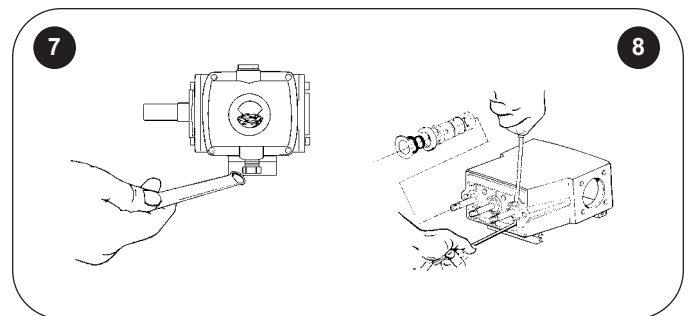
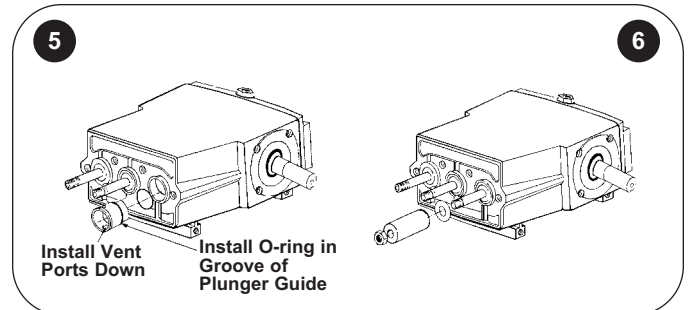
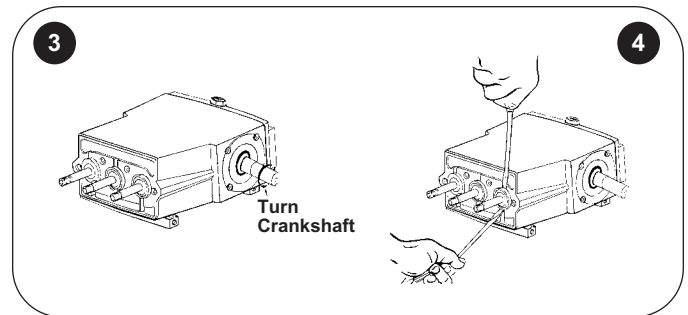
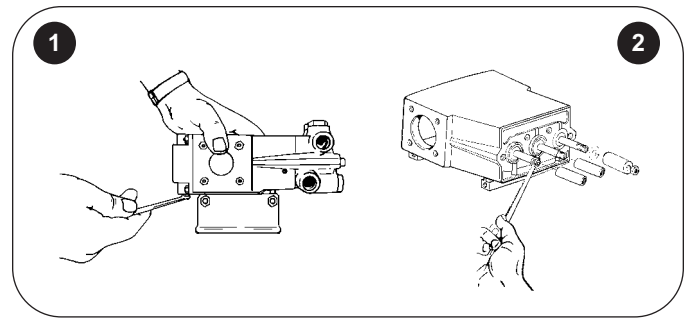

Plunger Replacement

1. Remove the pump head from the crankcase as described earlier in the packing replacement section.
2. Remove the plunger retaining nut and carefully slide the plunger off of the lower plunger. Remove the o-ring from the lower plunger. Remove the plunger retaining nut and slinger ring.
3. Inspect the plungers for cracking or damage, and replace if damaged. Always replace the slinger ring when a ceramic plunger is removed. This avoids fracturing the plunger when torquing the plunger retaining nut. Use Loctite 242 on the plunger nut. See the parts list for proper plunger kits.
4. Install new parts as follows:
 - a. Install the slinger ring onto lower plunger.
 - b. Lightly oil the lower plunger rod and install the o-ring backup seal into place.
 - c. Slide the plunger onto the lower plunger placing the end of the plunger containing the black ring towards the crankcase.
 - d. Install the plunger retaining nut washer and retaining nut onto the lower plunger. Torque the plunger nut with Loctite 271 to 100-115 in. lbs. for all models.
5. Install the new plunger packings as described in the packing replacement section.

Model 8000-0015 and 8000-0021 Gearbox Kits Installation

See the gearbox illustration and parts breakdown on Page 9.

1. Remove four 5/16" x 3/4" Allen head capscrews from the pump end cover on the shaft side of the pump with a 1/4" allen wrench.
2. Install the oil seal lip in the gearbox cover (Ref. 3). Install the gearbox cover over the pump shaft and align the holes. Put four copper washers (Ref. 14) onto four 5/16 x 1-1/4" Allen head bolts (Ref. 5) and apply two drops of Loctite (supplied) onto threads. Secure the gearbox cover to the pump with the bolts. (Torque to 150 in. lbs.)
3. Install the gasket (Ref. 4) onto the cover and align the gasket using the two dowel pins in the cover.
4. Insert the 1-1/4" key into the pump shaft keyway. Slide the driven gear (Ref. 6) onto the pump shaft with the gear teeth towards the pump. Slide the gear until it butts up against the shoulder on the pump shaft. Secure the gear with two set screws using a 5/32" Allen wrench.
5. Place the gearbox body (Ref. 12) onto the gearbox cover, again using the dowel pins as an alignment guide. Secure the gearbox body with five 5/6" x 1" Allen head capscrews (Ref. 9) using a 1/4" Allen wrench to tighten securely. (Torque to 150 in. lbs.)
6. Install the pump support bracket (Ref. 22) onto pump on opposite side from the gearbox. Secure with two 3/4" hex head bolts (supplied with pump) and tighten with 9/16" box end wrench.
7. Insert the 3-1/4" key for Model 8000-0015 or 2-1/2" key for Model 8000-0021 into the gas engine shaft keyway. Apply Never Seize to the gas engine shaft and the inside of the driver gear.
8. **Install the pump/gearbox assembly onto the gas engine shaft and secure with four hex head bolts and tighten securely with a 5/8" open end wrench for Model 8000-0015 and a 1/2" wrench for Model 8000-0021. Failure to follow this procedure will result in seal damage.**
9. Secure the pump support bracket to the base.
10. Remove the plug (Ref. 7) from overfill hole and dipstick (Ref. 10) and fill the gearbox with 90 weight gearlube until it pours out the overflow hole. Reinstall the plug and dipstick.
11. Make sure the pump is filled with 26 oz. of Hypro Oil. Refer to the recommended lubrication marked on the crankcase of the pump.

Unloader Valve Safety Information

1. Always size your unloader valve to match the capabilities of your system for pressure (psi) and volume (gpm).
2. In rigid-piped systems, a pulsation dampener or accumulator MUST be installed in the system. Select a dampener which conforms to the rated capacity.
3. Never replace the main spring with one of heavier tension to increase pressure. Never add washers to increase spring tension.
4. Always replace safety shields caps.
5. Secure all locking devices to eliminate the unloader from vibrating out of adjustment during operation.

Parts List 8000-0015 and 8000-0021 Gearboxes

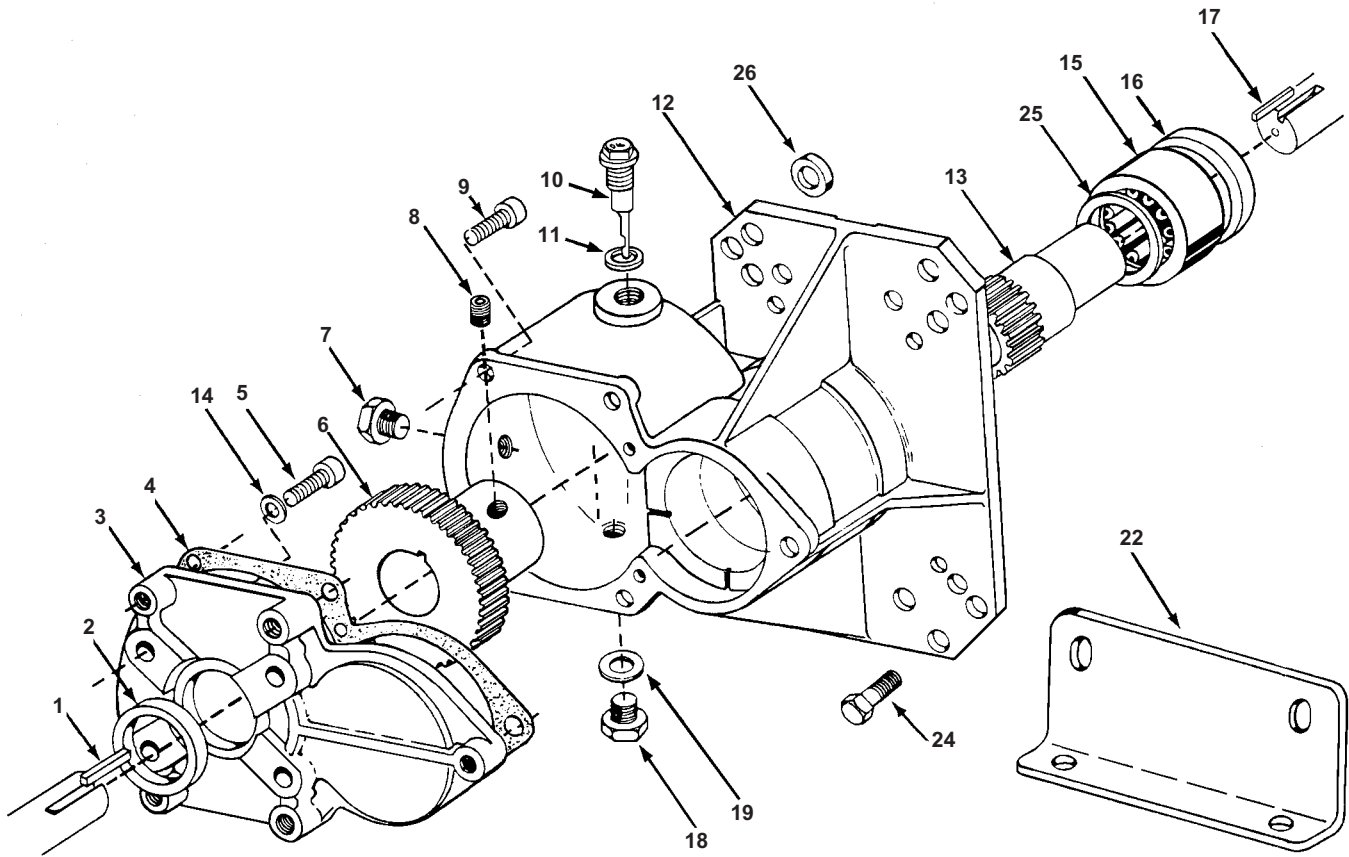

Ref. No.	Qty. Reqd.	Part Number	Description
1	1	1610-0021	Key (1-1/4" long)
2	1	2102-0017	Seal
3	1	0703-8800A	Gearbox cover
4	1	1710-0013	Gasket
5	4	2220-0055	Socket head bolt
6	1	3900-0032	Gear
7	1	2406-0012	Plug pipe
8	2	2230-0012	Set screw
9	5	2220-0056	Socket head bolt
10	1	2630-0010	Oil dipstick assembly
11	1	1700-0078	Gasket
12	1	0704-8800A	Gearbox body
13	1	3900-0033	Driver gear (Model 8000-0015)
13	1	3900-0037	Driver gear (Model 8000-0021)
14	4	2270-0012	Washer gasket
15	1	2007-0049	Needle bearing
16	1	2102-0020	Seal

Ref. No.	Qty. Reqd.	Part Number	Description
17	1	1610-0039	Key
17	1	1610-0040	Key (Model 8000-0021)
18	1	2406-0018	Drain plug
19	1	1700-0089	Washer gasket
22	1	1510-0064	Bracket (Model 8000-0021)
22	1	1510-0065	Bracket (Model 8000-0021)
22	1	1510-0066	Bracket (Model 8000-0015)
24	4	2210-0086	Hex head screw (Model 8000-0015)
24	4	2210-0077	Hex head screw (Model 8000-0021)
25	1	2265-0009	Thrust washer
26	4	1410-0084	Spacer (Model 8000-0015)
	2	1600-0056	Locating pin (not shown)
	2	2160-0017	Loctite (not shown)
	1	2160-0018	Anti-seize (not shown)

Models 2220B-P, 2221B-P, 2230B-P, 2231B-P

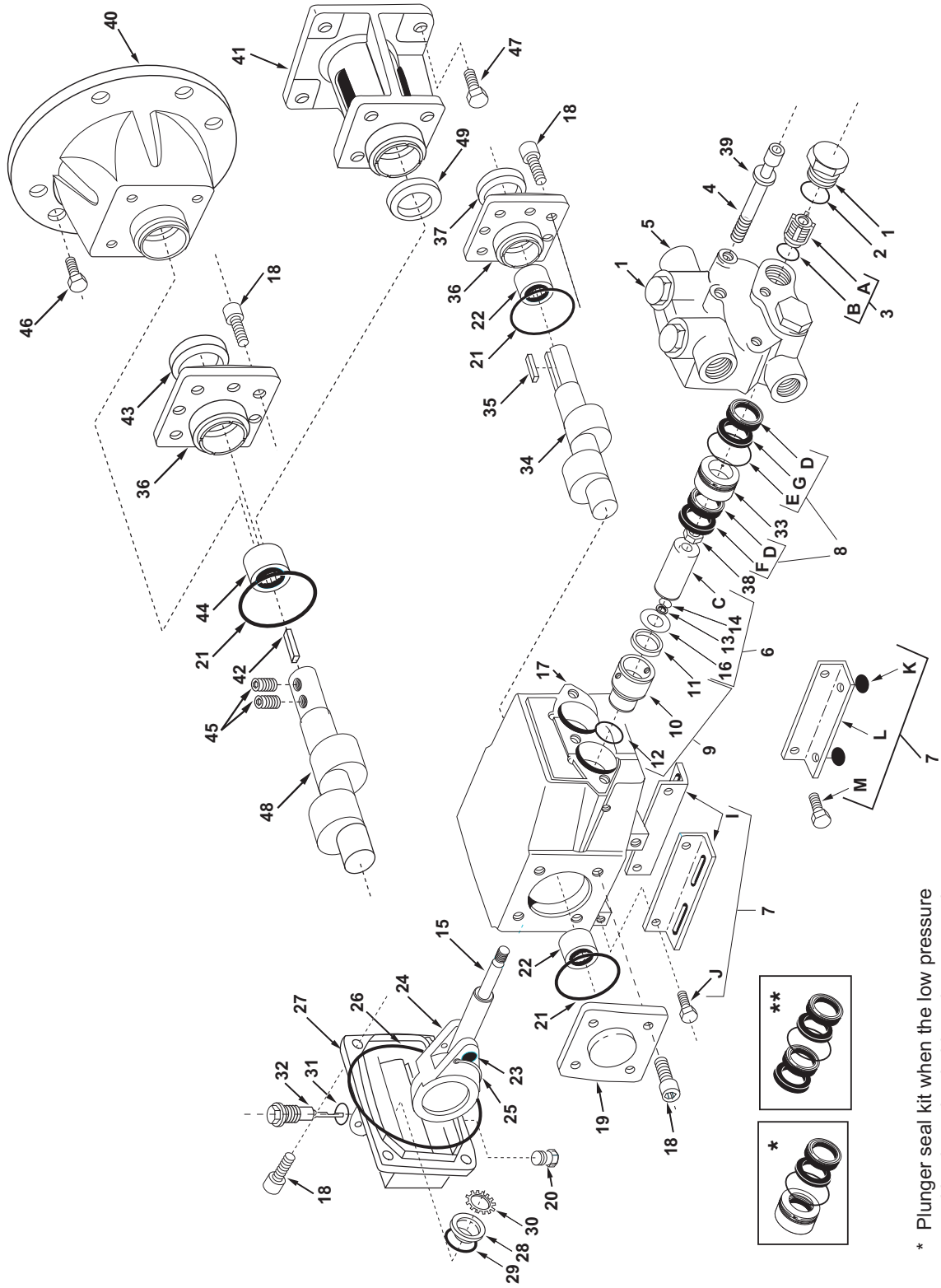

* Plunger seal kit when the low pressure packing is preloaded into the cup retainer.

** Plunger seal kit when the low pressure packing is not preloaded into the cup retainer.

PowerLine Plus Parts List

Models 2220B-P, 2221B-P, 2230B-P, 2231B-P

Ref. No.	Qty. Reqd.	Part Number	Description
1	4	2404-0302	Valve cap (aluminum)
1	4	2404-0300	Valve cap (brass)
2	4	1720-0205	O-ring
3	1 Set	3430-0506	Valve kit-STD (stainless steel) Consists of: 4 valve assemblies (Ref. A), 4 o-rings (Ref. B)
4	4	2220-0051	Socket head capscrew
4	4	2220-0101	Socket head capscrew (stainless steel)
5	1	0201-2200B	Head (brass)
5	1	0201-2200A	Head (aluminum) - Discontinued
6	2 Sets	3430-0514	Plunger kit Consists of: 1 o-ring, 1 ceramic plunger (Ref. C), 1 backup seal, 1 slinger ring
7	1 Set	3430-0243	Solid shaft base kit Consists of: 2 bases (Ref. I), 4 hex head capscrews (Ref. J)
7	1 Set	3430-0244	Hollow shaft base kit Consists of: 1 base (Ref. L), 2 rubber bumpers (Ref. K), 2 hex head cap screws (Ref. M)
8	1 Set	3430-0505	Plunger seal kit (Buna-N, standard) Consists of: 4 U-cups (Ref. D), 2 o-rings (Ref. E), 2 seal rings (Ref. F), and backup rings (Ref. G)
8	1 Set	3430-0501	Plunger seal kit (Viton) Consists of: 4 U-cups (Ref. D), 2 o-rings (Ref. E), 2 seal rings (Ref. F), and backup rings (Ref. G)
8	1 Set	3430-0521*	Plunger seal kit, loaded (Buna-N standard) Consists of: 4 U-cups (Ref. D), 2 o-rings (Ref. E), 2 seal rings (Ref. F), 2 backup rings (Ref. G), and 2 cup retainers (Ref. 33)
8	1 Set	3430-0518*	Plunger seal kit, loaded (Viton) Consists of: 4 U-cups (Ref. D), 2 o-rings (Ref. E), 2 seal rings (Ref. F), 2 backup rings (Ref. G), and 2 cup retainers (Ref. 33)
8	1 Set	3430-0524*	Plunger seal kit, loaded (aluminum head) Consists of: 4 U-cups (Ref. D), 2 o-rings (Ref. E), 2 seal rings (Ref. F), 2 backup rings (Ref. G), and 2 cup retainers (Ref. 33)
9	1 set	3430-0498	Oil seal repair kit Consists of: 2 inserts (Ref. 10), 2 oil seals (Ref. 11), 2 o-rings (Ref. 12)
10	2	0713-2300A	Insert
11	2	2102-0038	Oil seal
12	2	1720-0206	O-ring

Ref. No.	Qty. Reqd.	Part Number	Description
13	2	1760-0005	Backup seal
14	2	1720-0033	O-ring
15	2	3500-0068	Plunger rod
16	2	2270-0058	Slinger ring
17	1	0102-2200A	Crankcase
18	12	2220-0041	Socket head capscrew
19	1	0704-2200A	Endplate
20	1	2406-0019	Drain plug
21	2	1720-0131	O-ring
22	2	2007-0059	Needle bearing
23	2	2404-0299	Wrist pin
24	2	0501-8600A	Connecting rod
25	2	3270-0065	Spring retainer
26	1	1720-0136	O-ring
27	1	0713-2200A	Cover, crankcase
28	1	2630-0018	Sight glass
29	1	1720-0202	O-ring
30	1	1800-0016	Retainer
31	1	1720-0209	O-ring
32	1	2630-0008	Dipstick
32	1	2404-0188	Shipping plug (solid)
33	2	1830-0163	Cup retainer (brass head)
33	2	1830-0164	Cup retainer (aluminum head)
34	1	0501-8631F	Crankshaft (Model 2231B-P)
34	1	0501-8620F	Crankshaft (Model 2220B-P)
34	1	0501-8630F	Crankshaft (Model 2230B-P)
34	1	0501-8621F	Crankshaft (Model 2221B-P)
35	1	1610-0007	Key (solid shaft)
36	1	0702-2200A	End cover (solid shaft)
36	1	0703-2200A	End cover (5/8" hollow shaft)
37	1	2102-0014	Shaft seal (solid shaft)
38	2	2250-0051	Retaining nut
39	4	2270-0079	Lock washer
40	1	0708-2200A	C-flange end cover (5/8" hollow shaft)
41	1	0709-2200A	Gas engine end cover (5/8" hollow shaft)
41	1	0712-2200A	Gas engine end cover (3/4" hollow shaft)
42	1	1610-0011	Key (hollow shaft)
43	1	2102-0015	Seal (5/8" hollow shaft)
43	1	2102-0022	Seal (3/4" hollow shaft)
44	1	2007-0047	Bearing (5/8" hollow only)
44	1	2007-0051	Bearing (3/4" hollow only)
45	2	2230-0017	Set screw
46	4	2210-0020	Bolt
47	4	2210-0081	Bolt
48	1	0551-8620F	Crankshaft (Model 2220B-P)
48	1	0551-8630F	Crankshaft (Model 2230B-P)
48	1	0552-8621F	Crankshaft (Model 2221B-P)
48	1	0552-8631F	Crankshaft (Model 2231B-P)
48	1	0553-8631F	Crankshaft (Model 2231-C only)
49	1	2265-0010	Thrust washer (-C only)

* Plunger seal kit with low pressure packing preloaded into the cup retainer.

Note: See page 21 for Torque Specifications on above models.

**Models 2330B-P, 2331B-CP, 2340B-P, 2345B-P,
2351B-P, 2354B-CP and 2359B-P**

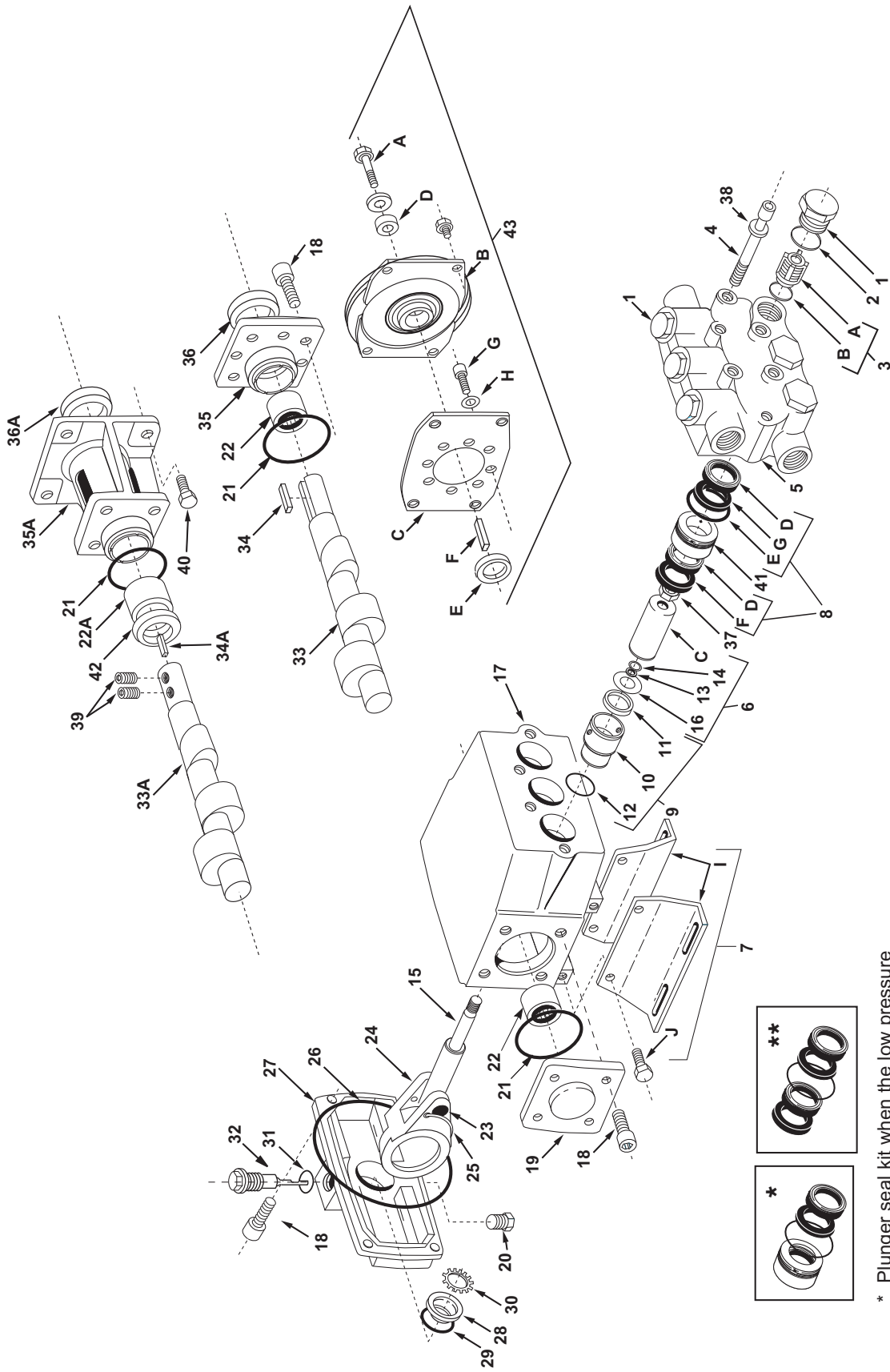

* Plunger seal kit when the low pressure packing is preloaded into the cup retainer.

** Plunger seal kit when the low pressure packing is not preloaded into the cup retainer.

PowerLine Plus Parts List

Models 2330B-P, 2331B-CP, 2340B-P, 2345B-P, 2351B-P, 2354B-CP, & 2359B-P

Ref. No.	Qty. Reqd.	Part Number	Description
1	6	2404-0300	Valve cap (brass)
1	1	2404-0305	Valve cap w/1/4" NPT port (optional)
2	6	1720-0205	O-ring
3	1 Set	3430-0491	Valve kit-std. (stainless steel) Consists of: 6 valve assemblies (Ref. A), 6 o-rings (Ref. B)
4	6	2220-0051	Socket head capscrew
4	6	2220-0101	Socket head capscrew (stainless steel)
5	1	0201-2300B	Head (brass)
6	3 Sets	3430-0514	Plunger kit (Models 2330B-P, 2340B-P, 2345B-P and 2331B-CP) Consists of: 1 o-ring, 1 plunger (Ref. C), 1 backup seal, 1 slinger ring
6	3 Sets	3430-0513	Plunger kit (Models 2359B-P, 2354B-CP and 2351B-P) Consists of: 1 o-ring, 1 plunger (Ref. C), 1 backup seal, 1 slinger ring
7	1 Set	3430-0269	Base kit Consists of: 2 bases (Ref. I), 4 hex head capscrews (Ref. J)
8	1 Set	3430-0493	Plunger seal kit (Buna-N, standard) (Models 2330B-P, 2331B-CP, 2340B-P and 2345B-P) Consists of: 6 U-cups (Ref. D), 3 o-rings (Ref. E), 3 seal rings (Ref. F), 3 backup rings (Ref. G)
8	1 Set	3430-0492	Plunger seal kit (Buna-N, standard) (Models 2359B-P, 2351B-P and 2354B-CP) Consists of: 6 U-cups (Ref. D), 3 o-rings (Ref. E), 3 seal rings (Ref. F), 3 backup rings (Ref. G)
8	1 Set	3430-0502	Plunger seal kit (Viton) (Models 2330B-P, 2331B-CP, 2340B-P, and 2345B-P) Consists of: 6 U-cups (Ref. D), 3 o-rings (Ref. E), 3 seal rings (Ref. F), and 3 backup rings (Ref. G)
8	1 Set	3430-0523*	Plunger seal kit, loaded (Buna-N, standard) (Models 2330B-P, 2331B-CP, 2340B-P, 2345B-P) Consists of: 6 U-cups (Ref. D), 3 o-rings (Ref. E), 3 seal rings (Ref. F), 3 backup rings (Ref. G), and 3 cup retainers (Ref. 41)
8	1 Set	3430-0522*	Plunger seal kit, loaded (Buna-N, standard) (Models 2359B-P, 2351B-P, 2354B-CP) Consists of: 6 U-cups (Ref. D), 3 o-rings (Ref. E), 3 seal rings (Ref. F), 3 backup rings (Ref. G), and 3 cup retainers (Ref. 41)
8	1 Set	3430-0519*	Plunger seal kit, loaded (Viton) (Models 2330B-P, 2331B-CP, 2340B-P, 2345B-P) Consists of: 6 U-cups (Ref. D), 3 o-rings (Ref. E), 3 seal rings (Ref. F), 3 backup rings (Ref. G), and 3 cup retainers (Ref. 41)
9	1 set	3430-0499	Oil seal repair kit Consists of: 3 inserts (Ref. 10), 3 oil seals, (Ref. 11) and 3 o-rings (Ref. 12)
10	3	0713-2300A	Insert
11	3	2102-0038	Oil seal
12	3	1720-0206	O-ring

Ref. No.	Qty. Reqd.	Part Number	Description
13	3	1760-0005	Backup seal
14	3	1720-0033	O-ring
15	3	3500-0068	Plunger rod
16	3	2270-0058	Slinger ring
17	1	0102-2300A	Crankcase
18	12	2220-0041	Socket head capscrew
19	1	0704-2200A	End plate
20	1	2406-0019	Drain plug
21	2	1720-0131	O-ring
22	2	2007-0059	Needle bearing (solid shaft)
22A	1	2007-0051	Needle bearing (3/4" hollow shaft)
23	3	2404-0299	Wrist pin
24	3	0501-8600A	Connecting rod
25	3	3270-0065	Spring retainer
26	1	1720-0203	O-ring
27	1	0707-2300A	Cover
28	1	2630-0018	Sight glass
29	1	1720-0202	O-ring
30	1	1800-0016	Retainer
31	1	1720-0209	O-ring
32	1	2630-0008	Dipstick
32	1	2404-0188	Shipping plug
33	1	0502-8730F	Crankshaft (Model 2330B-P)
33	1	0502-8740F	Crankshaft (Models 2340B-P and 2359B-P)
33	1	0503-8745F	Crankshaft (Model 2345B-P and 2351B-P)
33A	1	0551-8731F	Crankshaft (Model 2331B-CP and 2354B-CP)
34	1	1610-0007	Key (solid shaft)
34A	1	1610-0011	Key (hollow shaft)
35	1	0702-2200A	End Cover
35A	1	0712-2200A	End cover for gas engine
36	1	2102-0014	Shaft Seal (solid shaft)
36A	1	2102-0022	Shaft seal (hollow shaft)
37	3	2250-0051	Retaining Nut
38	6	2270-0079	Lock Washer
39	2	2230-0017	Set screw
40	4	2210-0081	Bolt
41	3	1830-0162	Cup Retainer (Models 2359B-P, 2351B-P, 2354B-CP)
41	3	1830-0163	Cup Retainer (Models 2330B-P, 2331B-CP, 2340B-P, and 2345B-P)
42	1	2265-0010	Thrust washer (-C only)
43	1	8000-0042	Clutch Kit (Model 2359B-PY)* Consists of: 1 clutch assembly (Ref. B), 1 bracket (Ref. C), 1 small spacer (Ref. D), 1 large spacer (Ref. E), 1 key (Ref. F), 4 socket head cap screws (Ref. G) and 4 washers (Ref. H). *Fits 2359B-P and 2340B-P

Note: See page 21 for Torque Specifications on above models.

* Plunger seal kit with low pressure packing preloaded into the cup retainer.

Models 2303B-P, 2304B-P and 2314B-P

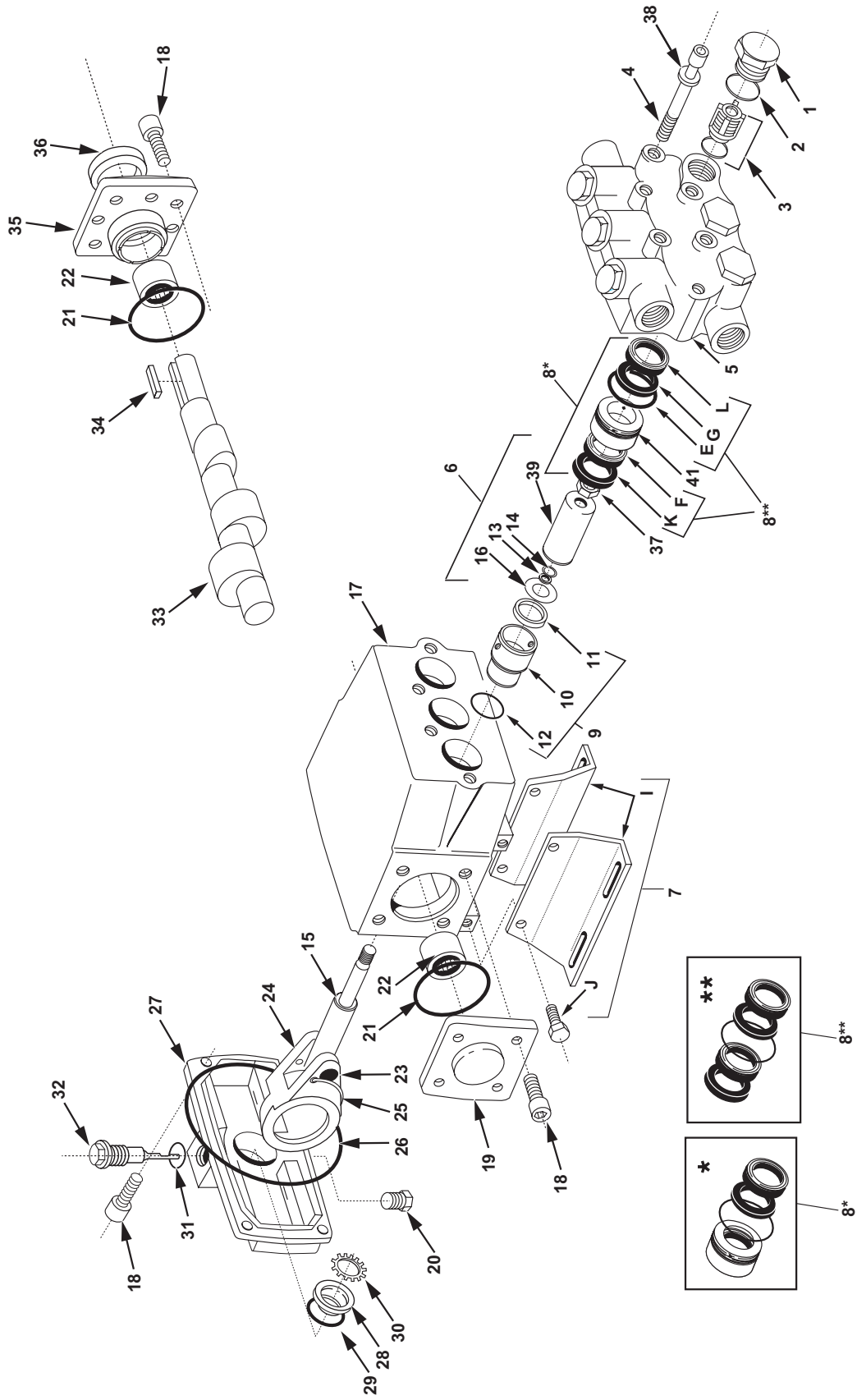

Car Wash Parts List

Models 2303B-P, 2304B-P and 2314B-P

Ref. No.	Qty. Reqd.	Part Number	Description
1	6	2404-0300	Valve cap (brass)
1	1	2404-0305	Valve cap w/1/4" NPT port (optional)
2	6	1720-0205	O-ring
3	1 Set	3430-0491	Valve kit-std. (stainless steel) Consists of: 6 valve assemblies, 6 o-rings
4	6	2220-0051	Socket head capscrew
4	6	2220-0101	Socket head capscrew (stainless steel)
5	1	0201-2300B	Head (brass)
6	3 Sets	3430-0514	Plunger kit consists of: 1 o-ring, 1 plunger, 1 backup seal, 1 slinger ring
7	1 Set	3430-0269	Base kit consists of: 2 bases (Ref. I), 4 hex head capscrews (Ref. J)
7	1 Set	3430-0530	Optional base kit (Cat 310 & 5CP) Consists of: 2 bases (Ref. I), 4 hex head capscrews (Ref. J)
8	1 Set	3430-0539**	Plunger seal kit (car wash seals only) (Models 2303B-P, 2304B-P, & 2314B-P) Consists of: 3 high psi seals (Ref. L), 3 o-rings (Ref. E), 3 vacuum seals (Ref. K), 3 backup rings (Ref.G), 3 low psi cups (Ref. F)
8	1 Set	3430-0533*	Plunger seal kit, loaded (Buna-N, standard) (Models 2303B-P 2304B- P, & 2314B-P) Consists of: 3 high psi seals (Ref. L), 3 o-rings (Ref. E), 3 vacuum seals, 3 backup rings (Ref. G), 3 cup retainers (Ref. 41), and 3 low psi u-cups (Ref. F).
9	1 set	3430-0534	Oil seal repair kit consists of: 3 inserts (Ref. 10), 3 oil seals, (Ref. 11) and 3 o-rings (Ref. 12)

Ref. No.	Qty. Reqd.	Part Number	Description
10	3	0714-2300A	Insert
11	3	2102-0038	Oil seal
12	3	1720-0206	O-ring
13	3	1760-0005	Backup seal
14	3	1720-0033	O-ring
15	3	3500-0068	Plunger rod
16	3	2270-0058	Slinger ring
17	1	0102-2300A	Crankcase
18	12	2220-0041	Socket head capscrew
19	1	0704-2200A	End plate
20	1	2406-0019	Drain plug
21	2	1720-0131	O-ring
22	2	2007-0059	Needle bearing (solid shaft)
23	3	2404-0299	Wrist pin
24	3	0501-8600A	Connecting rod
25	3	3270-0065	Spring retainer
26	1	1720-0203	O-ring
27	1	0707-2300A	Cover
28	1	2630-0018	Sight glass
29	1	1720-0202	O-ring
30	1	1800-0016	Retainer
31	1	1720-0209	O-ring
32	1	2630-0008	Dipstick
32	1	2404-0188	Shipping plug
33	1	0502-8730F	Crankshaft (Model 2303B-P)
33	1	0502-8740F	Crankshaft (Models 2304B-P)
33	1	0503-8745F	Crankshaft (Model 2314B-P)
34	1	1610-0007	Key (solid shaft)
35	1	0702-2200A	End Cover
36	1	2102-0014	Shaft Seal (solid shaft)
37	3	2250-0051	Retaining Nut
38	6	2270-0079	Lock Washer
39	1	3500-0070	Plunger
41	3	1830-0163	Cup Retainer (Models 2303B-P, 2304B-P, 2314B-P)

* Plunger seal kit with low pressure packing preloaded into the cup retainer.

** Seals (not pre-loaded) only.

Note: See page 21 for Torque Specifications on above models.

**Models 2410B-P, 2411B-P, 2412B-P, 2413B-P, 2414B-P,
2430B-P, 2431B-P, 2432B-P, 2433B-P and 2434B-P**

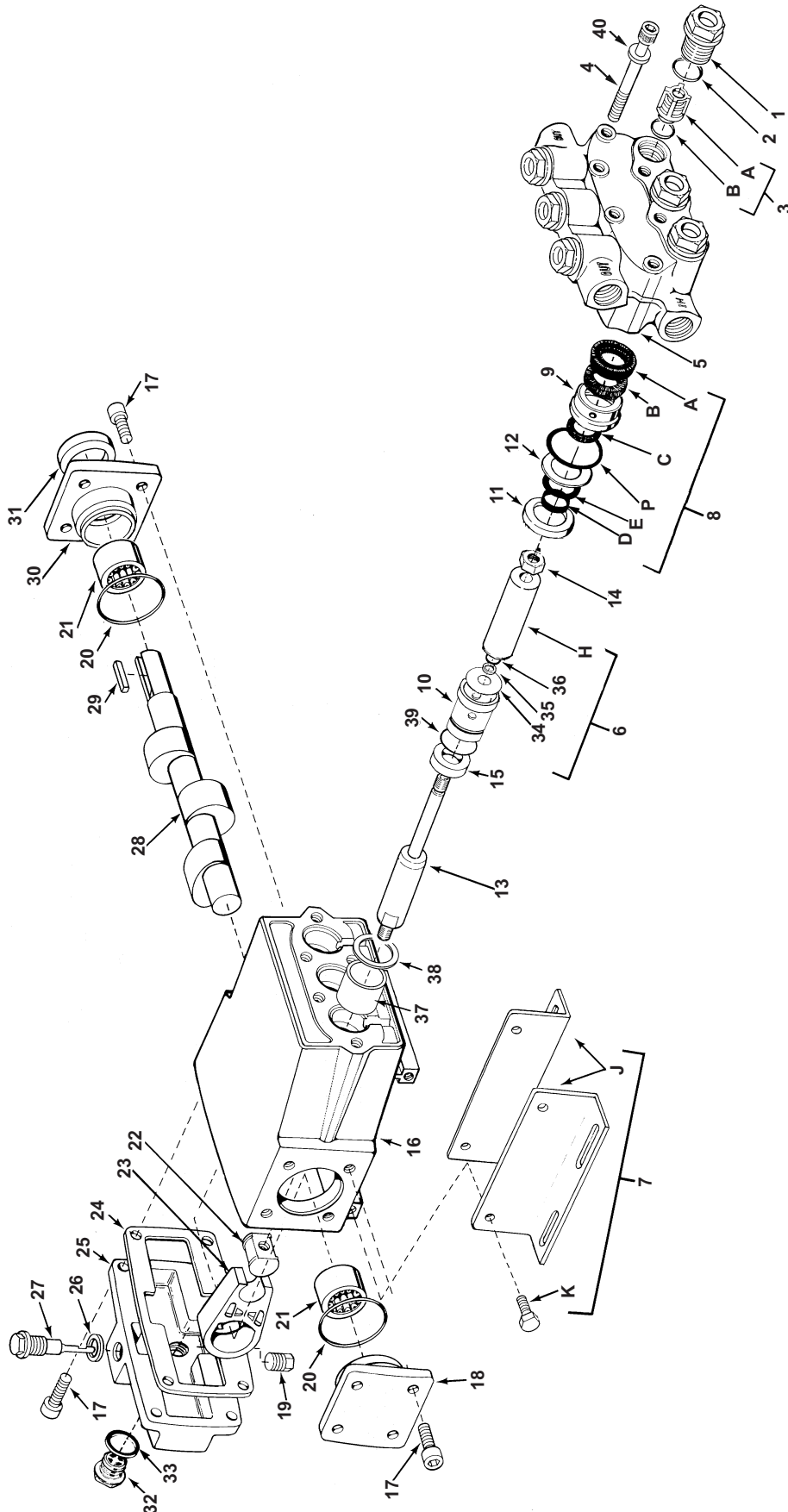

PowerLine Plus Parts List

Models 2410B-P, 2411B-P, 2412B-P, 2413B-P, 2414B-P, 2430B-P, 2431B-P, 2432B-P, 2433B-P and 2434B-P

Ref. No.	Qty. Reqd.	Part Number	Description
1	6	0707-2400B	Valve cap
2	6	1720-0135	O-ring
3	1 Set	3430-0316	Valve kit Consists of: 6 valve assemblies (Ref. A), 6 o-rings (Ref. B)
4	6	2220-0029	Head bolt
5	1	0203-2400B	Forged brass head
6	3 Sets	3430-0321	Plunger kit (Models 2410B-P, 2411B-P, 2412B-P, 2430B-P, 2431B-P, and 2432B-P) Consists of: 1 backup seal, 1 plunger (Ref. H), 1 slinger ring, 1 o-ring
6	3 Sets	3430-0322	Plunger kit (Models 2413B-P, 2414B-P, 2433B-P, and 2434B-P) Consists of: 1 backup seal, 1 plunger (Ref. H), 1 slinger ring, 1 o-ring
7	1 Set	3430-0303	Base kit (standard) Consists of: 2 bases (Ref. J), 4 bolts (Ref. K)
7	1 Set	3430-0304	Base kit (Cat 310 mounting) Consists of: 2 bases (Ref. L), 4 bolts (Ref. M)
7	1 Set	3430-0305	Base kit (Cat 530 mounting) Consists of: 2 bases (Ref. L), 4 bolts (Ref. M)
8	1 Set	3430-0485	Seal kit (Models 2410B-P, 2411B-P, 2412B-P, 2430B-P, 2431B-P, and 2432B-P) Consists of: 3 high pressure seals (Ref. A), 3 backup rings (Ref. B), 6 o-rings (Ref. 3B), 3 low pressure seals (Ref. C), 3 seal rings (Ref. D), 3 o-rings (Ref. E), 3 o-rings (Ref. P)
8	1 Set	3430-0486	Seal kit (Models 2413B-P, 2414B-P, 2433B-P, and 2434B-P) Consists of: 6 high pressure seals (Ref. A & C) 3 backup rings (Ref. B), 6 o-rings (Ref. 3B), 3 seal rings (Ref. D), 3 o-rings (Ref. E), 3 o-rings (Ref. P)
9	3	1830-0159	Retainer ring (Models 2410B-P, 2411B-P, 2412B-P, 2430B-P, 2431B-P, and 2432B-P)
9	3	1830-0158	Retainer ring (Models 2413B-P, 2414B-P, 2433B-P, and 2434B-P)
10	3	1830-0169	Seal retainer - All Models
11	3	1830-0167	Vac seal retainer (Models 2410B-P, 2411B-P, 2412B-P, 2430B-P, 2431B-P, and 2432B-P)

Ref. No.	Qty. Reqd.	Part Number	Description
11	3	1830-0166	Vac seal retainer (Models 2413B-P, 2414B-P, 2433B-P, and 2434B-P)
12	3	1830-0160	Retainer (Models 2410B-P, 2411B-P, 2412B-P, 2430B-P, 2431B-P and 2432B-P)
12	3	1830-0168	Retainer (Models 2413B-P, 2414B-P, 2433B-P, and 2434B-P)
13	3	3500-0062	Lower plunger guides
14	3	2250-0051	Retaining nut
15	3	2102-0018	Oil seal
16	1	0102-2400A	Crankcase
17	16	2220-0053	Bolt
18	1	0701-2400A	End cover
19	1	2406-0019	Plug
20	2	1720-0136	O-ring
21	2	2002-0006	Bearing (Models 2410B-P, 2411B-P, 2412B-P, 2413B-P and 2414B-P) (ball bearing)
21	2	2009-0001	Bearing (Models 2430B-P, 2431B-P, 2432B-P, 2433B-P, and 2434B-P) (roller bearing)
22	3	2404-0169	Wrist pin
23	3	0500-8800A	Connecting rod
24	1	1700-0095	End cover gasket
25	1	0703-2400A	End cover
26	1	1700-0078	Gasket
27	1	2630-0010	Oil dipstick assembly
27	1	2404-0188	Shipping plug (solid)
28	1	0501-8850D	Crankshaft (Models 2410B-P and 2430B-P)
28	1	0501-8851D	Crankshaft (Models 2411B-P, 2413B-P, 2431B-P, and 2433B-P)
28	1	0501-8852D	Crankshaft (Models 2412B-P, 2414B-P, 2432B-P, and 2434B-P)
29	1	1610-0021	Key
30	1	0700-2400A	End cover
31	1	2102-0017	Seal
32	1	2630-0011	Oil sight glass
33	1	1700-0094	Gasket
34	3	2270-0059	Slinger ring
35	3	1760-0005	Backup seal
36	3	1720-0033	O-ring
37	3	1440-0085	Guide
38	3	1830-0155	Guide retainer
39	3	1720-0061	O-ring
40	6	2270-0083	Washer

Note: See page 21 for Torque Specifications on above models.

Performance Charts for PowerLine Plus 2300s

U.S. Units

Metric Units

Model 2359B-P	PSI	500		700		1000		1300		2000		3000	
	RPM	GPM	HP	GPM	HP	GPM	HP	GPM	HP	GPM	HP	GPM	HP
	1000	2.1	1.0	2.1	1.6	2.1	2.0	2.1	2.3	2.0	2.8	2.0	4.0
1450	3.0	1.4	3.0	2.3	3.0	2.8	2.9	3.2	2.9	4.1	2.9	5.6	5.6
1600	3.3	1.6	3.3	2.6	3.3	3.2	3.3	3.4	3.2	4.4	3.2	6.2	6.2
1725	3.6	1.6	3.6	2.7	3.5	3.3	3.5	3.8	3.5	4.8	3.4	6.8	6.8

BAR	34			48		69		90		138		207	
	RPM	L/m	Kw	L/m	Kw	L/m	Kw	L/m	Kw	L/m	Kw	L/m	Kw
	1000	7.9	0.7	7.9	1.2	7.9	1.5	7.9	1.7	7.6	2.1	7.6	3.0
1450	11.4	1.0	11.4	1.7	11.4	2.1	11.0	2.4	11.0	3.1	11.0	4.2	4.2
1600	12.5	1.2	12.5	1.9	12.5	2.4	12.5	2.5	12.1	3.3	12.1	4.6	4.6
1725	13.6	1.2	13.6	2.0	13.2	2.5	13.2	2.8	13.2	3.6	12.9	5.1	5.1

Model 2351B-P	PSI	500		700		1000		1300		2000		3000	
	RPM	GPM	HP	GPM	HP	GPM	HP	GPM	HP	GPM	HP	GPM	HP
	1000	2.4	0.9	2.3	1.7	2.3	2.1	2.3	2.4	2.3	3.1	2.3	4.3
1450	3.4	1.4	3.4	2.4	3.4	3.0	3.3	3.4	3.3	4.4	3.2	6.3	6.3
1600	3.8	1.6	3.7	2.7	3.7	3.3	3.7	3.7	3.6	4.8	3.6	7.0	7.0
1725	4.0	1.7	4.0	2.9	4.0	3.5	4.0	4.0	3.9	5.1	3.8	7.4	7.4

BAR	34			48		69		90		138		207	
	RPM	L/m	Kw	L/m	Kw	L/m	Kw	L/m	Kw	L/m	Kw	L/m	Kw
	1000	9.1	0.7	8.7	1.3	8.7	1.6	8.7	1.8	8.7	2.3	8.7	3.2
1450	12.9	1.0	12.9	1.8	12.9	2.2	12.5	2.5	12.5	3.3	12.1	4.7	4.7
1600	14.4	1.2	14.0	2.0	14.0	2.5	14.0	2.8	13.6	3.6	13.6	5.2	5.2
1725	15.1	1.3	15.1	2.2	15.1	2.6	15.1	3.0	14.8	3.8	14.4	5.5	5.5

Model 2331B-CP	PSI	500		700		1000		1300		1500	
	RPM	GPM	HP	GPM	HP	GPM	HP	GPM	HP	GPM	HP
	1800	1.9	1.0	1.9	1.2	1.8	1.5	1.8	1.8	1.8	2.1
2600	2.7	1.4	2.6	1.7	2.6	2.2	2.6	2.7	2.5	3.0	3.0
2875	2.9	1.5	2.9	1.9	2.8	2.4	2.8	2.8	2.8	3.2	3.2
3450	3.4	1.9	3.4	2.2	3.3	2.8	3.3	3.4	3.3	3.8	3.8

BAR	34			48		69		90		103	
	RPM	L/m	Kw	L/m	Kw	L/m	Kw	L/m	Kw	L/m	Kw
	1800	7.2	0.7	7.2	0.9	6.8	1.1	6.8	1.3	6.8	1.6
2600	10.2	1.0	9.8	1.3	9.8	1.6	9.8	2.0	9.5	2.2	2.2
2875	11.0	1.1	11.0	1.4	10.6	1.8	10.6	2.1	10.6	2.4	2.4
3450	12.9	1.4	12.9	1.6	12.5	2.1	12.5	2.5	12.5	2.8	2.8

Model 2354B-CP	PSI	500		1000		1500		2000	
	RPM	GPM	HP	GPM	HP	GPM	HP	GPM	HP
	2800	2.4	1.3	2.3	2.0	2.3	2.7	2.2	3.4
3000	2.6	1.4	2.5	2.2	2.4	2.9	2.3	3.7	3.7
3200	2.7	1.6	2.6	2.4	2.6	3.2	2.5	3.9	3.9
3400	2.9	1.6	2.8	2.4	2.7	3.3	2.6	4.0	4.0

BAR	34			69		103		138	
	RPM	L/m	Kw	L/m	Kw	L/m	Kw	L/m	Kw
	2800	9.1	1.0	8.7	1.5	8.7	2.0	8.3	2.5
3000	9.8	1.0	9.5	1.6	9.1	2.2	8.7	2.8	2.8
3200	10.2	1.2	9.8	1.8	9.8	2.4	9.5	2.9	2.9
3400	11.0	1.2	10.6	1.8	10.2	2.5	9.8	3.0	3.0



Hazardous Substance Alert



1. Always drain and flush pumps before servicing or disassembling for any reason (see instructions).
2. Always drain and flush pumps prior to returning the units for repair.
3. Never store pumps containing hazardous chemicals.
4. Before returning a pump for service/repair, drain out all liquids and flush the unit with a neutralizing liquid. Then, drain the pump. Attach a tag or include a written notice certifying that this has been done. Please note that it is illegal to ship or transport any hazardous chemicals without United States Environmental Protection Agency Licensing.

Torque Specifications

Model	Head Bolts	Valve Caps	Cover Bolts	Plunger Nut	
2200B-P	105-115 in. lbs.	60 ft. lbs.	90-100 in. lbs.	105-115 in. lbs.	} Use Blue Locktite No. 242 on all plungers and nuts.
2300B-P	105-115 in. lbs.	60 ft. lbs.	90-100 in. lbs.	105-115 in. lbs.	
2400B-P	170 in. lbs.	85 ft. lbs.	100-110 in. lbs.	115-120 in. lbs.	

Troubleshooting

Symptom	Probable Cause(s)	Corrective Action
Pump runs but produces no flow.	Pump is not primed.	Flood suction, then restart pump.
Pump fails to prime.	Air is trapped inside pump.	Disconnect discharge hose from pump. Flood suction hose, restart pump, and run pump until all air has been evacuated.
Pump loses prime. Chattering noise, pressure fluctuates.	Air leak in suction hose or inlet fittings.	Remove suction hose and test for leaks by pressurizing hose with water. Make sure thread sealant has been used on all fittings.
	Suction line is blocked, collapsed or too small.	Remove suction line and inspect it for a loose liner or debris lodged in hose. Avoid all unnecessary bends. Do not kink hose.
	Clogged suction strainer.	Clean strainer.
Low pressure at nozzle.	Unloader valve is bypassing.	Make sure unloader is adjusted properly and bypass seat is not leaking.
	Incorrect or worn nozzle.	Make sure nozzle is matched to the flow and pressure of the pump. If the nozzle is worn, replace.
	Restricted intake.	Refer to above priming information.
Pressure loss in general.	Screen clogged.	Check the screen for debris and clean or replace.
	Inlet size too small.	Make sure it is big enough.
	Worn or clogged valves are stuck due to rust.	Inspect valves for rust, wear, pitting and debris and replace if necessary.
	Unloader bypassing.	Plumbed wrong. See if the flow is diverting out of the bypass line.
	System leaks.	Check for leaks.

Note: Cavitation Will Damage Your Pump!

Cavitation occurs when an inadequate amount of fluid is available for feeding the pump.

To check for possible cavitation:

- Test the water flow that will feed the pump by filling a one or five-gallon container and timing how long it takes to fill the vessel; i.e. if your unit requires 3 gallons per minute to satisfy the specifications, your water supply (free flow) should exceed 3 gpm, and preferably 1.5 to 2 times the required flow.

If it takes the supply water noticeably longer to fill the test container to the gallons per minute that your system requires, your pump could be experiencing cavitation. Cavitation can severely damage seals, pistons and valves and will shorten the life of all components in the hydraulic system.

To Avoid Cavitation:

- Keep the size of the suction line as large as possible, preferably the same size (or larger) as the inlet port.
- Use high-capacity, clean line strainers.

- Install a fitting at the suction side so you can check the vacuum periodically. The vacuum should not exceed 2-3 inches of Hg to obtain the best operation.
- Protect the pump from overheating.
 - Protect it from direct sunlight in hot weather.
 - Maintain adequate ventilation.
 - Keep lubricating fluids clean and at full levels.
- Protect the pump from severe cold by covering or operating indoors.
- Make sure the pump is secure and can't move around.
- Control the pressure with unloader valves and balanced relief valves. To prevent pressure spikes, don't over tighten the control valves.
- Use a pulsation dampener. Soft hose works well.
- To avoid vacuum leak, prevent the system from flowing against gravity.
- In a gravity-fed system, keep the rate of flow from gravity the same (or more) as the feed requirements of the pump.

•NOTES•

•NOTES•

Limited Warranty on Hypro PowerLine Plus 2000 Plunger Pumps

Hypro warrants to the original purchaser of its products (the "Purchaser") that oil crankcase plunger pumps will be free from defects in material and workmanship under normal use for the period of five (5) years, and accessories will be free from defects in material and workmanship under normal use for the period of ninety (90) days. In addition, Hypro warrants to the purchaser all forged brass pump manifolds will be free from defects in material and workmanship under normal use and from damage resulting from environmental conditions for the life of the pump.

"Normal use" does not include use in excess of recommended maximum speeds, pressures, vacuums and temperatures, or use requiring handling of fluids not compatible with component materials, as noted in Hypro product catalogs, technical literature, and instructions. This warranty does not cover freight damage, freezing damage, normal wear and tear, or damage caused by misapplication, fault, negligence, alterations, or repair that affects the performance or reliability of the product.

THIS WARRANTY IS EXCLUSIVE. HYPRO MAKES NO OTHER WARRANTY, EXPRESS OR IMPLIED, INCLUDING BUT NOT LIMITED TO ANY WARRANTY OF MERCHANTABILITY OR FITNESS FOR A PARTICULAR PURPOSE.

Hypro's obligation under this warranty is, at Hypro's option, to either repair or replace the product upon return of the entire product to the Hypro factory in accordance with the return procedures set forth below. **THIS IS THE EXCLUSIVE REMEDY FOR ANY BREACH OF WARRANTY.**

IN NO EVENT SHALL HYPRO BE LIABLE FOR ANY INCIDENTAL OR CONSEQUENTIAL DAMAGES OF ANY KIND, WHETHER FOR BREACH OF ANY WARRANTY, FOR NEGLIGENCE, ON THE BASIS OF STRICT LIABILITY, OR OTHERWISE.

Return Procedures

All pumps or products must be flushed of any chemical (ref. OSHA Section 0910.1200 (d)(e)(f)(g)(h)) and hazardous chemicals must be labeled before being shipped* to Hypro for service or warranty consideration.

Hypro reserves the right to request a Material Safety Data sheet from the Purchaser for any pump or product Hypro deems necessary. Hypro reserves the right to "disposition as scrap" pumps or products returned which contain unknown substances, or to charge for any and all costs incurred for chemical testing and proper disposal of components containing unknown substances. Hypro requests this in order to protect the environment and personnel from the hazards of handling unknown substances.

For technical or application assistance, call the **Hypro Technical/Application number: 800-445-8360**, or send an email to: **technical@hypropumps.com**. To obtain service or warranty assistance, call the **Hypro Service and Warranty number: 800-468-3428**; or send a fax to the **Hypro Service and Warranty FAX: 651-766-6618**. Be prepared to give Hypro full details of the problem, including the following information:

1. Model number and the date and from whom you purchased your pump.
2. A brief description of the pump problem, including the following:
 - Liquid pumped. State the pH and any non-soluble materials, and give the generic or trade name.
 - Temperature of the liquid and ambient environment.
 - Suction lift or vacuum (measured at the pump).
 - Discharge pressure.
 - Size, type, and mesh of the suction strainer.
 - Drive type (gas engine/electric motor, direct/belt drive, tractor PTO) and rpm of pump.
 - Viscosity (of oil, or other than water weight liquid).
 - Elevation from the pump to the discharge point.
 - Size and material of suction and discharge line.
 - Type of spray gun, orifice size, unloader/relief valve.

Hypro may request additional information and may require a sketch to illustrate the problem. Contact the factory to receive a return material authorization before sending the product. All pumps returned for warranty work should be sent shipping charges prepaid to:

HYPRO / PENTAIR
Attention: Service Department
375 Fifth Avenue NW
New Brighton, Minnesota 55112

* Carriers, including U.S.P.S., airlines, UPS, ground freight, etc., require specific identification of any hazardous materials being shipped. Failure to do so may result in a substantial fine and/or prison term. Check with your shipping company for specific instructions.



375 Fifth Avenue NW • New Brighton, MN 55112
Phone: (651) 766-6300 • 800-424-9776 • Fax: 800-323-6496
www.hypropumps.com