

### SUBJECT: Recommended Storage of Hydra-Cell Pumps

If a Hydra-Cell pump is to be stored for a long period of time, precautions should be taken so that the pump will be in good operating condition when ready for use.

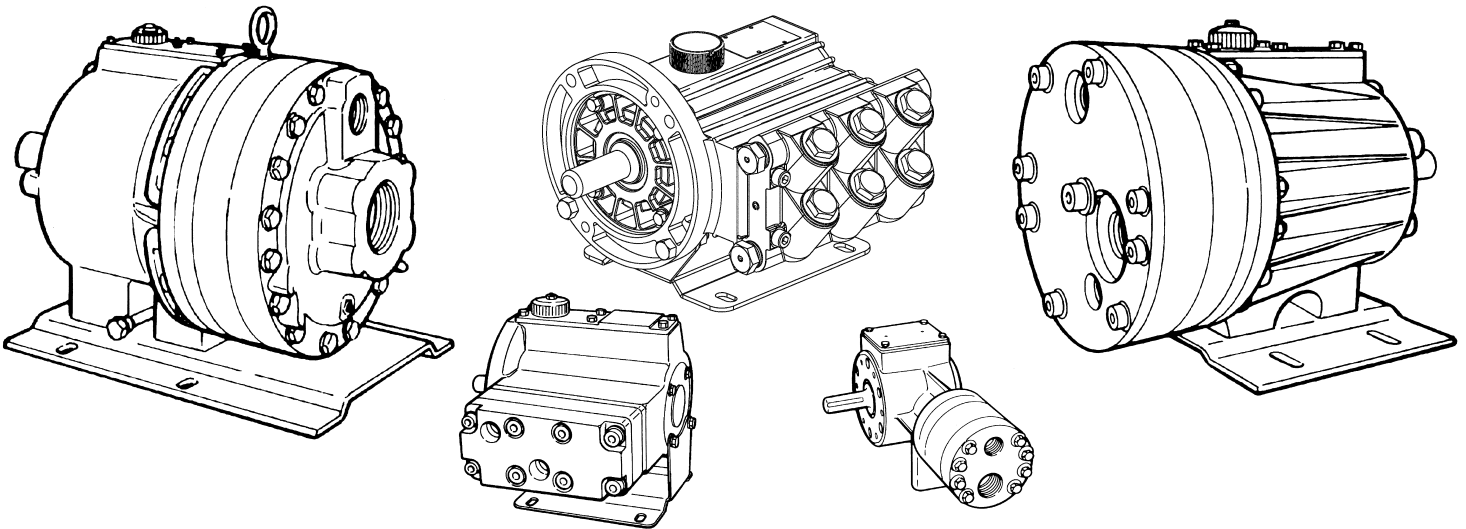

### Basic Recommendations

#### After Shut Down of the pump:

- Drain all process fluid from pump. Do not drain oil from the pump. **Caution – do not store the pump without oil in the reservoir.**
- Flush the fluid end of the pump with a corrosion inhibitor that is compatible with the diaphragm material and process fluid.
- Coat camshaft or crankshaft with rust preventative; wrap with wax-impregnated cloth and then with waterproof tape.
- Plug the suction and discharge ports of the pump to protect against dirt and moisture.
- Store in a clean, dry place.

#### Prior to Start-up of the Pump:

- Drain and refill the hydraulic end of the pump with the appropriate Hydra-Oil.

#### Wanner Engineering, Inc.

1204 Chestnut Avenue  
Minneapolis, MN 55403 USA  
Phone: 612-332-5681  
Fax: 612-332-6937  
Toll-Free Fax (USA): 800-332-6812  
Email: sales@wannereng.com  
www.Hydra-Cell.com

#### Wanner International Ltd.

Units 8 & 9, Fleet Business Park  
Sandy Lane, Church Crookham  
Hampshire GU52 8BF, England  
Phone: +(44) 01252 816847  
Fax: +(44) 01252 629242  
Email: sales@wannerint.com  
www.hydra-cell.eu

#### Wanner Pumps Ltd.

Flat A, 21/F, Chatham Commercial Building  
399 Chatham Road North  
Hungghom, Kowloon, HONG KONG  
Phone: +(852) 3428-6534  
Fax: +(852) 3188-9145  
Email: sales@wannerpumps.com  
www.WannerPumps.com