

# Hydra•Cell<sup>®</sup>

## METERING SOLUTIONS™

## Electronic Precision Metering Pumps

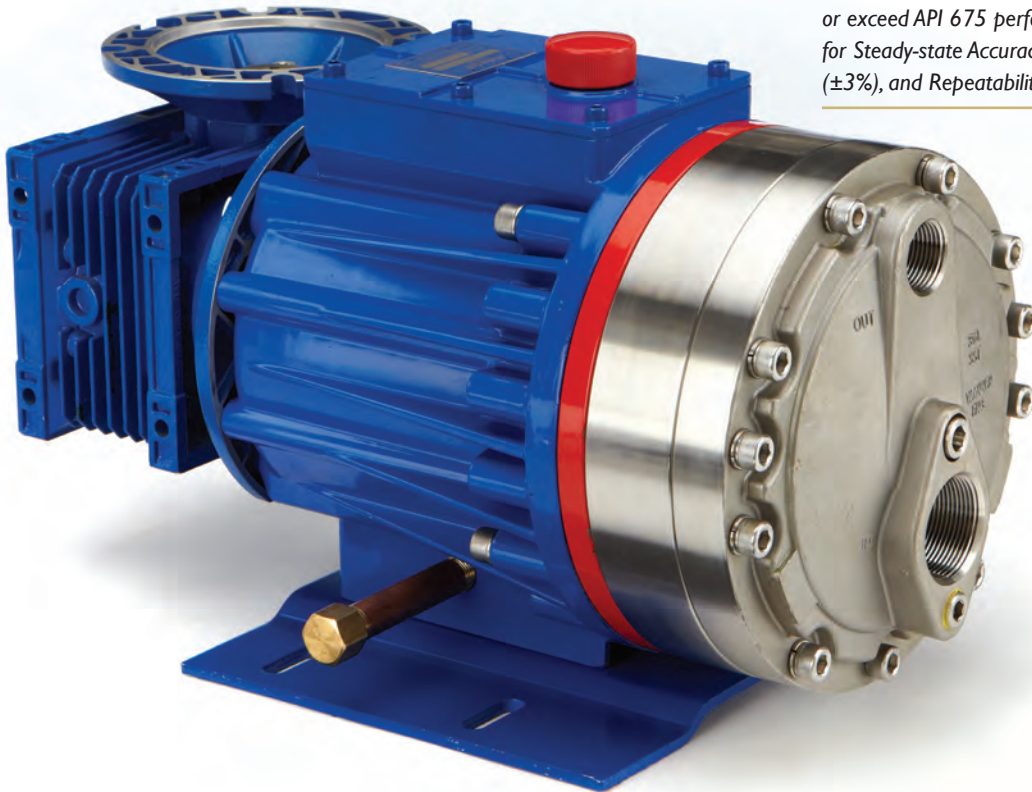

Hydra-Cell Metering Solutions pumps meet or exceed API 675 performance standards for Steady-state Accuracy ( $\pm 1\%$ ), Linearity ( $\pm 3\%$ ), and Repeatability ( $\pm 3\%$ ).

### P600 Series

- Designed to handle a wide range of fluids from clear water to thick slurries.
- Electronic flow control increases accuracy and reliability.
- Multiple-diaphragm design provides linear, virtually pulse-less flow.
- Smaller footprint saves valuable space.
- One pump covers a wide range of flows and pressures - reducing inventory requirements with fast, simple field conversion.
- Duplexing option doubles capacity and equipment savings.
- Hydraulically-actuated, balanced diaphragms provide superior performance across entire pressure range.

# P600 Series

Maximum Flow Rate: 894.6 gph

Maximum Pressure: 1000 psi for Metallic Pump Heads

350 psi for Non-metallic Pump Heads

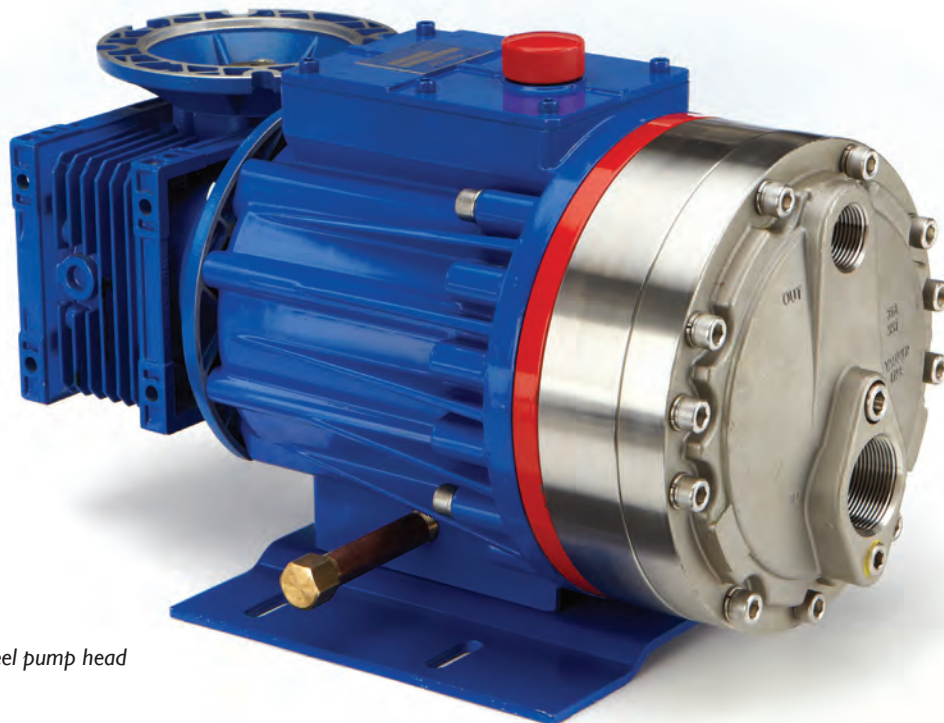

P600 with Stainless Steel pump head

## Performance\* Maximum Flow at Designated Pressure

All Pumps (gph)		Metallic Pump Heads Only (gph)		Pump rpm	Gear Ratio	Motor rpm
100 psi	250 psi	500 psi	1000 psi			
22.43	22.27	21.89	20.77	18	100:1	1800
28.03	27.79	27.31	26.05	22.5	80:1	
37.34	36.99	36.34	34.84	30	60:1	
44.80	44.35	43.57	41.87	36	50:1	
55.98	55.39	54.40	52.42	45	40:1	
74.62	73.79	72.46	70.01	60	30:1	
89.52	88.51	86.91	84.07	72	25:1	
111.9	110.6	108.6	105.2	90	20:1	
149.2	147.4	144.7	140.3	120	15:1	
223.7	221.0	216.9	210.7	180	10:1	
298.2	294.6	289.2	281.0	240	7.5:1	
447.3	441.8	433.7	421.7	360	5:1	
596.4	589.0	578.1	562.4	480	7.5:1	3600
894.6	883.4	867.1	843.7	720	5:1	

\* Capacity data is shown for pumps with elastomeric diaphragms. Consult factory for performance characteristics of pumps with PTFE diaphragms.

## Required Motor hp

1/4	1/2	3/4	1	1-1/2	2	3	5	7-1/2	10
-----	-----	-----	---	-------	---	---	---	-------	----

## Pump Data

Diaphragms per Liquid End	3
Flow Control	Electronic variable speed drive
Maximum Discharge Pressure	
Metallic Heads:	1000 psi (69 bar)
Non-metallic Heads:	PVDF- 350 psi (24 bar) Polypropylene- 250 psi (17 bar)
Maximum Inlet Pressure	250 psi (17 bar)
Maximum Operating Temperature	
Metallic Heads:	250 °F (121 °C)*
Non-metallic Heads:	140 °F (60 °C)
Inlet Port	1-1/2 inch NPT or BSPT
Discharge Port	1 inch NPT or BSPT
Weight (less motor)**	
Metallic Heads:	141 lbs (64 kg)
Non-metallic Heads:	106 lbs (48 kg)
Dimensions (less motor)**	
Metallic Heads:	21.0" W x 10.7" D x 11.2" H (533 mm W x 272 mm D x 285 mm H)
Non-metallic Heads:	21.8" W x 10.7" D x 11.2" H (554 mm W x 272 mm D x 285 mm H)

\* Consult factory for correct component selection for temperatures from 160 °F (71 °C) to 250 °F (121 °C).

\*\* For 56C motor frame only. Consult factory for other motor frame sizes.

## Representative Dimensional Drawings (Inches)

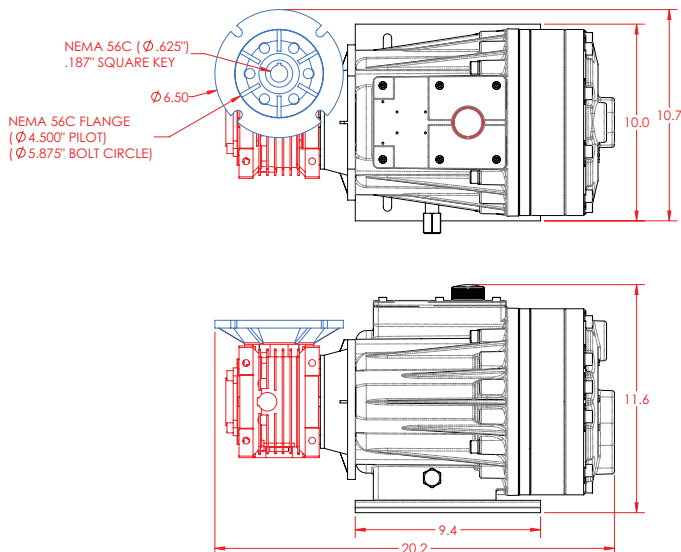

## How to Order

A complete pump order number contains 13 digits based on the specified pump materials listed below.

1	2	3	4	5	6	7	8	9	10	11	12	13
P	6	0	0									

### Pump Model Size (Digits 1-4)

**P600** For all P600 Pumps

### Pump Version (Digit 5)

**N** NPT Ports or ANSI Flanges  
**M** BSPT Ports

### Pump Head Material (Digit 6)

**C** Cast Iron  
**M** PVDF  
**P** Polypropylene  
**R** 316L Stainless Steel (ANSI flange weldment)  
**S** 316L Stainless Steel (NPT or BSPT)  
**T** Hastelloy CW12MW

### Diaphragm & O-ring Material (Digit 7)▲

**E** EPDM  
**G** FKM  
**J** PTFE  
**P** Neoprene  
**T** Buna-N  
▲ See price list for different actuating oils available with these materials.

### Check Valve Material (Digits 8-9)

#### (Valve Spring / Valve & Seat)

**SS** 316L SST / 316L SST  
**TT** Hastelloy C / Hastelloy C  
**SC** 316L SST / Ceramic  
**TC** Hastelloy C / Ceramic

### Gearbox Ratio (Digits 10-12)

<b>100</b>	100:1	(56C Motor Frame)
<b>080</b>	80:1	(56C Motor Frame)
<b>060</b>	60:1	(56C Motor Frame)
<b>050</b>	50:1	(56C Motor Frame)
<b>040</b>	40:1	(56C Motor Frame)
<b>A40</b>	40:1	(143/145TC Motor Frame)
<b>030</b>	30:1	(56C Motor Frame)
<b>A30</b>	30:1	(143/145TC Motor Frame)
<b>025</b>	25:1	(56C Motor Frame)
<b>A25</b>	25:1	(143/145TC Motor Frame)
<b>020</b>	20:1	(56C Motor Frame)
<b>A20</b>	20:1	(143/145TC Motor Frame)
<b>015</b>	15:1	(56C Motor Frame)
<b>A15</b>	15:1	(143/145TC Motor Frame)
<b>010</b>	10:1	(56C Motor Frame)
<b>A10</b>	10:1	(143/145TC Motor Frame)
<b>B10</b>	10:1	(182/184TC Motor Frame)
<b>007</b>	7.5:1	(56C Motor Frame)
<b>A07</b>	7.5:1	(143/145TC Motor Frame)
<b>B07</b>	7.5:1	(182/184TC Motor Frame)
<b>C07</b>	7.5:1	(213/215TC Motor Frame)
<b>005</b>	5:1	(56C Motor Frame)
<b>A05</b>	5:1	(143/145TC Motor Frame)
<b>B05</b>	5:1	(182/184TC Motor Frame)
<b>C05</b>	5:1	(213/215TC Motor Frame)

### Base Plate (Digit 13)

**C** Carbon Steel (Epoxy painted)  
**H** Carbon Steel (Epoxy painted) for B and C reducers

# Hydra•Cell<sup>®</sup>

## METERING SOLUTIONS™

### **Wanner Engineering, Inc.**

#### **World Headquarters & Manufacturing**

Wanner Engineering, Inc.  
1204 Chestnut Avenue,  
Minneapolis, MN 55403 USA  
Phone: 612-332-5681 • Fax: 612-332-6937  
Toll-Free Fax (USA): 800-332-6812  
Email: sales@wannereng.com  
www.Hydra-Cell.com

207 US Highway 281  
Wichita Falls, TX 76310 USA  
Phone: 940-322-7111  
Toll-Free: 800-234-1384  
Email: sales@wannereng.com  
www.Hydra-Cell.com

#### **Latin American Office**

R. Álvaro Anes, 150 Bairro Campestre  
Santo André/São Paulo, Brazil - CEP 09070-030  
Phone: (11) 4081-7098  
Email: mmagoni@wannereng.com  
www.Hydra-Cell.com

### **Wanner International Ltd.**

Wanner International, Ltd.  
Hampshire - United Kingdom  
Phone: +44 (0) 1252 816847  
Email: sales@wannerint.com  
www.Hydra-Cell.eu

### **Wanner Pumps Ltd.**

Wanner Pumps, Ltd.  
Kowloon - Hong Kong  
Phone: +852 3428 6534  
Email: sales@wannerpumps.com  
www.WannerPumps.com

Shanghai - China  
Phone: +86-21-6876 3700  
Email: sales@wannerpumps.com  
www.WannerPumps.com

Guangzhou - China  
Phone: +86-20-8920 2730  
Email: sales@wannerpumps.com  
www.WannerPumps.com

