

NEMA 143/5TC FLANGE
 Ø4.500 PILOT
 Ø5.875 BOLT CIRCLE

NEMA 143/5TC
 Ø.875
 0.187 SQUARE KEY

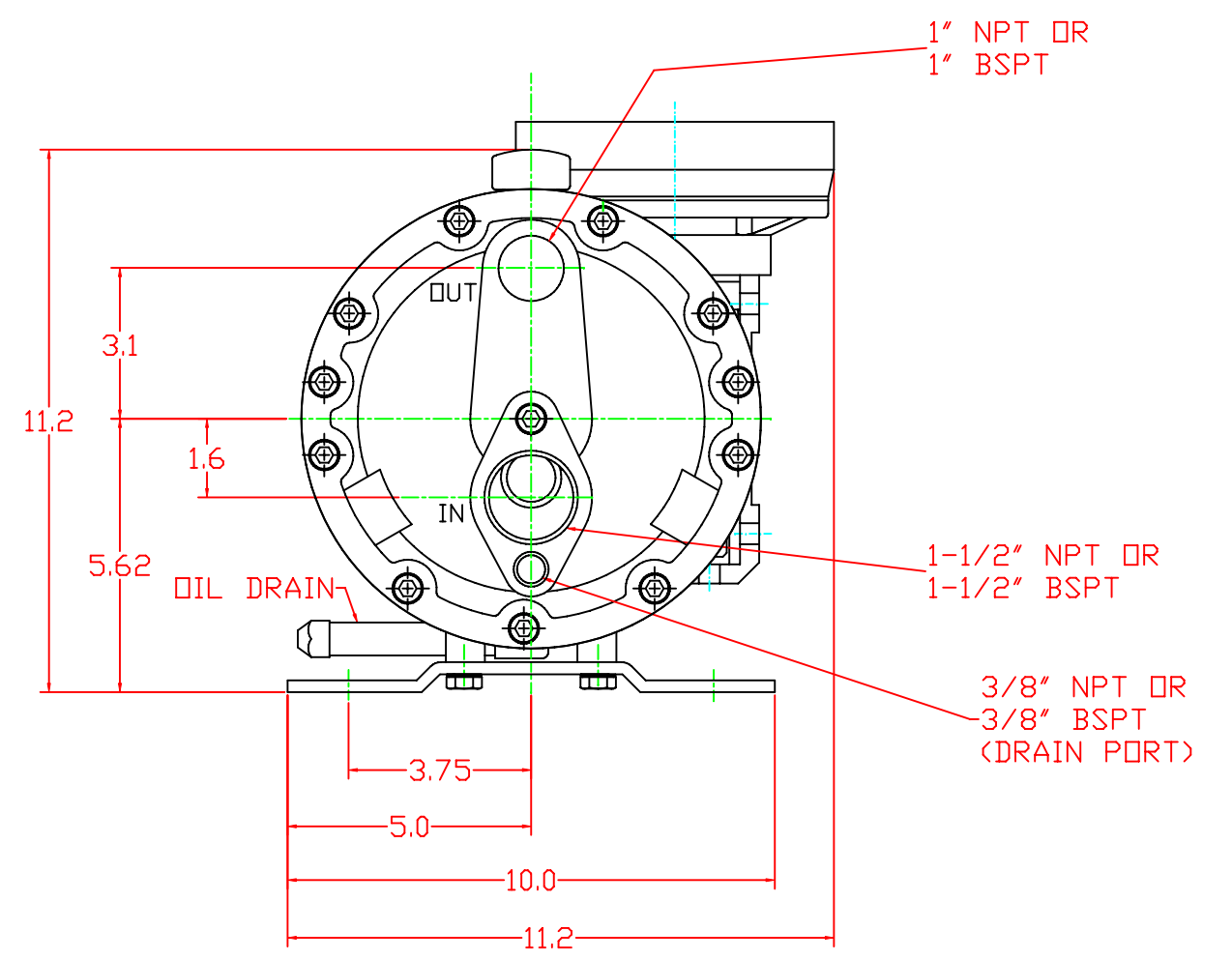
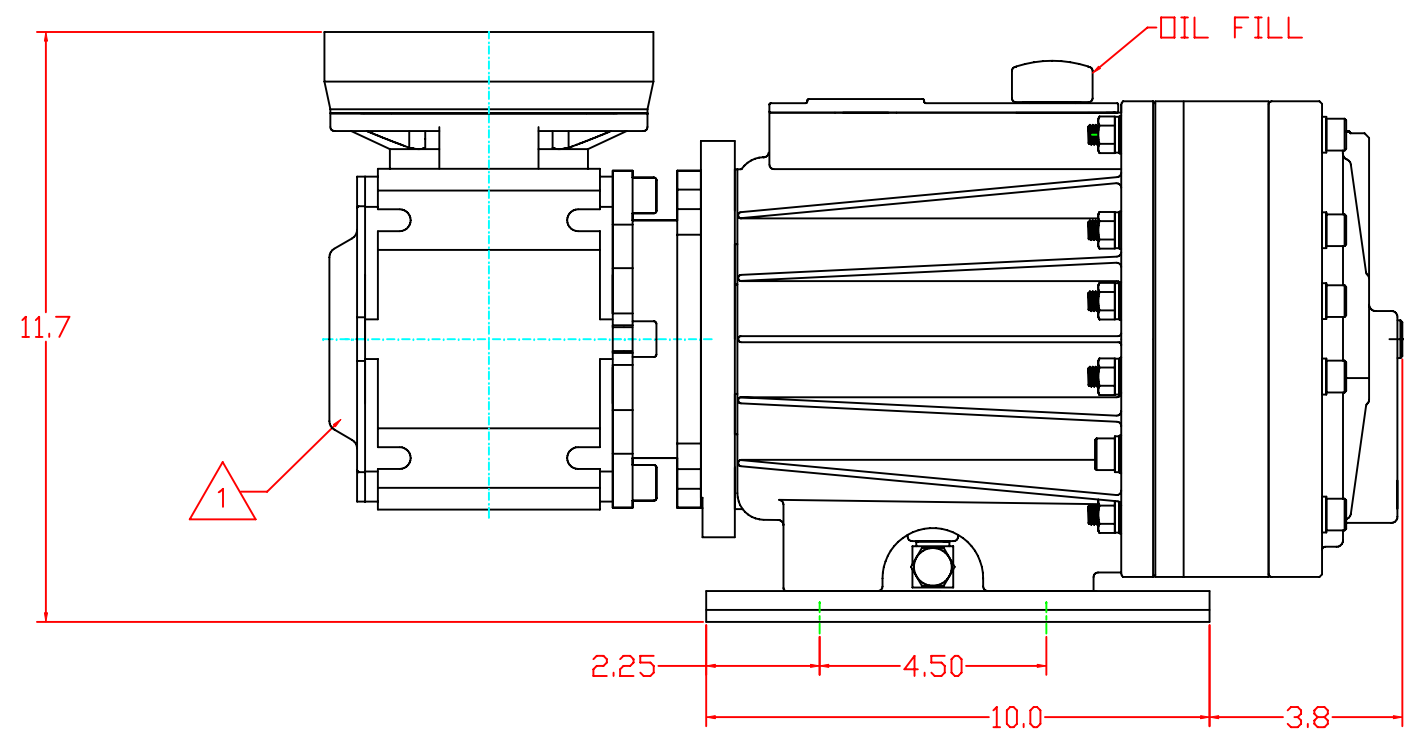
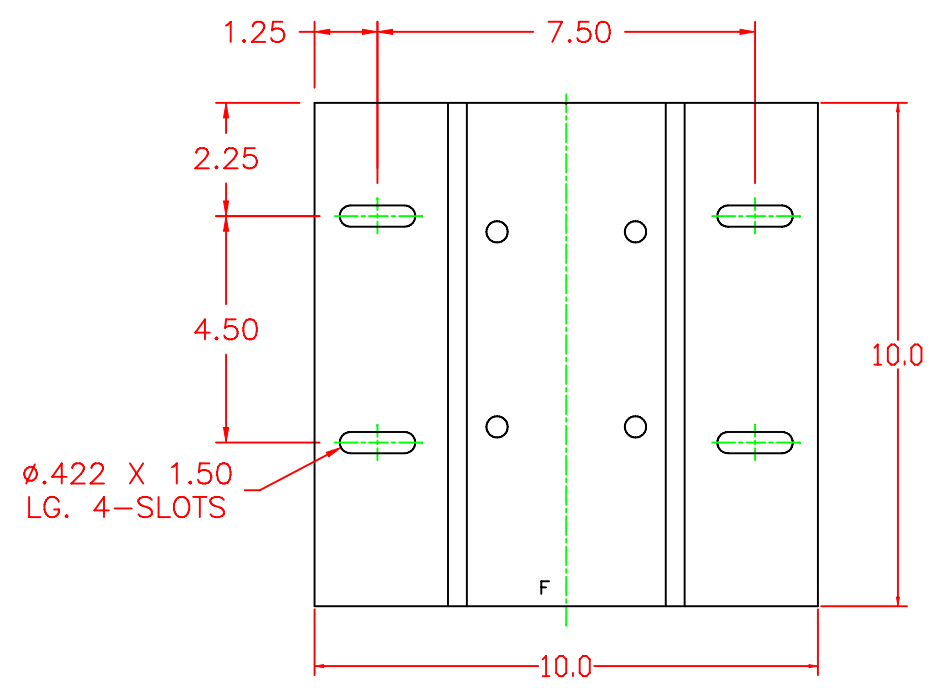
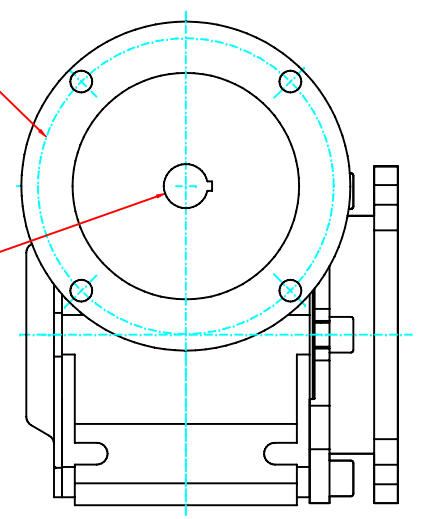

NOTES:

- WORM GEAR REDUCER AVAILABLE IN THE FOLLOWING RATIO'S:
 - 5:1, 7.5:1
- WEIGHT = 161 LBS (73 KG) - DOES NOT INCLUDE MOTOR.

UNLESS OTHERWISE SPECIFIED		MAT'L PUMPING HEAD AVAILABLE C.I., 316 SST OR HAST C.	
- ALL DIMENSIONS ARE IN INCHES.		TOL UNLESS NOTED	DWN 08-11-06 JJH
- DRAWING MAY NOT BE TO SCALE		.X = ± .020	CHK'D
- ALL DIMENSIONS APPLY AFTER PLATING, COATING AND HEAT TREATING, BUT BEFORE PAINTING.		.XX = ± .010	APP'D
- REMOVE ALL BURRS, BREAK ALL SHARP EDGES AND CORNERS		.XXX = ± .005	USED ON:
PROPRIETARY STATEMENT		ANGLES = ± .50°	SHEET 1 OF 1
This document contains confidential and proprietary information and is not to be reproduced or the information contained therein disclosed to others without consent, in writing, from WANNER ENGINEERING INC.		FINISH: 125 RMS	SCALE 1:2
		FORM DBLK	FORM DBLK
		WANNER ENGINEERING INC 1204 CHESTNUT AVE. MPLS, MN 55403	
		TITLE DIM DWG, P600, FB75, 140TC	
		DWG NO	
		REV. A	
		P600-DIM-METAL-FB75-140TC	