

**Installation & Service**

**D03-991-2404**

# **Hydra-Cell<sup>®</sup>**

## **INDUSTRIAL PUMPS**

**Models: D-03, G-03, G-13, M-03 and M-23**  
**Mono-Block Kel-Cell Versions**

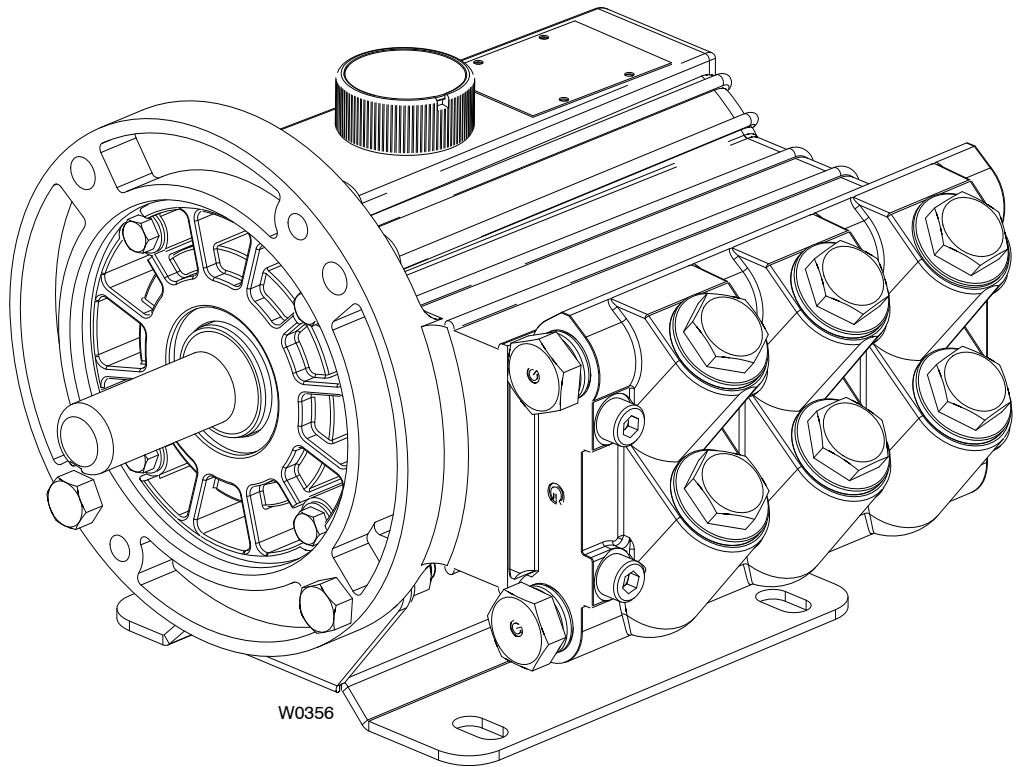

**WANNER ENGINEERING, INC.**

1204 Chestnut Avenue, Minneapolis, MN 55403  
TEL: (612) 332-5681 FAX: (612) 332-6937  
TOLL-FREE FAX [US only]: (800) 332-6812

[www.hydra-cell.com](http://www.hydra-cell.com)  
email: [sales@wannereng.com](mailto:sales@wannereng.com)

# D/G-03 Mono-Block Contents

	Page
Specifications.....	2
Dimensions .....	4
Installation.....	6
Maintenance.....	9
Fluid End Service.....	10
Hydraulic End Service .....	14
Troubleshooting .....	17
Warranty.....	19

## Component Identification

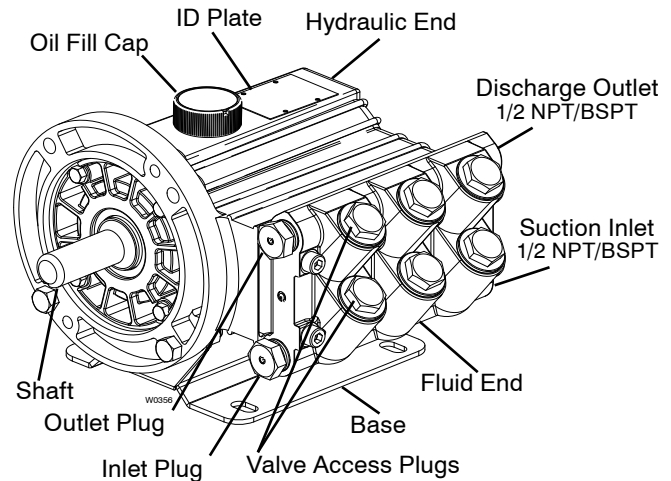

## Specifications

### Max Pressure

Metallic Heads:

D/G-03-X (Kel-Cell)\*: 1000 psi (70 bar);

D/G-03-E (Kel-Cell)\*: 1000 psi (70 bar),

### Capacity@ Max Pressure

	rpm	gpm	l/min
D/G-03-X (Kel-Cell)*	1750	3.0	11.3
D/G-03-E (Kel-Cell)*	1750	2.2	8.3

### Delivery @ Max Pressure\*

	revs/gal	revs/liter
D/G-03-X (Kel-Cell)*	584	155
D/G-03-E (Kel-Cell)*	795	204

**Max Inlet Pressure** 250 psi (17 bar)

### Max Temperature

Metallic Heads: 250°F (121°C) – consult factory for temperatures above 160°F (71°C)

### Inlet Port

D-03, M-03, M-23: 1/2 inch NPT  
G-03, G-13: 1/2 inch BSPT

### Discharge Port

D-03, M-03, M-23: 1/2 inch NPT  
G-03, G-13: 1/2 inch BSPT

\* Mono-Block Kel-Cell available in X and E models only.

### Shaft Diameter

D-03/G-03: 7/8 inch (22.22) shaft driven

M-03: 5/8 inch hollow (for NEMA 56C C-Face motor)

G-13: 24 mm hollow shaft (for IEC 90L, B5 Flange motor)

M-23: 20 mm hollow shaft (for use with Honda Engine)

### Shaft Rotation

Bi-directional

### Bearings

Ball bearings

### Oil Capacity

1 US quarts (0.95 liters)

### Weight

Metallic Heads: 28 lbs (12.7 kg)

### Note:

Performance and specification ratings apply to all configurations unless specifically noted otherwise. Kel-Cell pumps available in D/G-03-X and D/G-03-E configurations only.

## Calculating Required Horsepower (kW)‡

$$\frac{6 \times \text{rpm}}{63,000} + \frac{\text{gpm} \times \text{psi}}{1,460} = \text{electric motor HP}^*$$

$$\frac{6 \times \text{rpm}}{84,428} + \frac{\text{lpm} \times \text{bar}}{511} = \text{electric motor kW}^*$$

‡ rpm equals pump shaft rpm. HP/kW is required application power. Use caution when sizing motors with variable speed drives. Consult engine manufacturer for gasoline or diesel power requirements.

# D/G-03 Mono-Block Specifications

## Performance

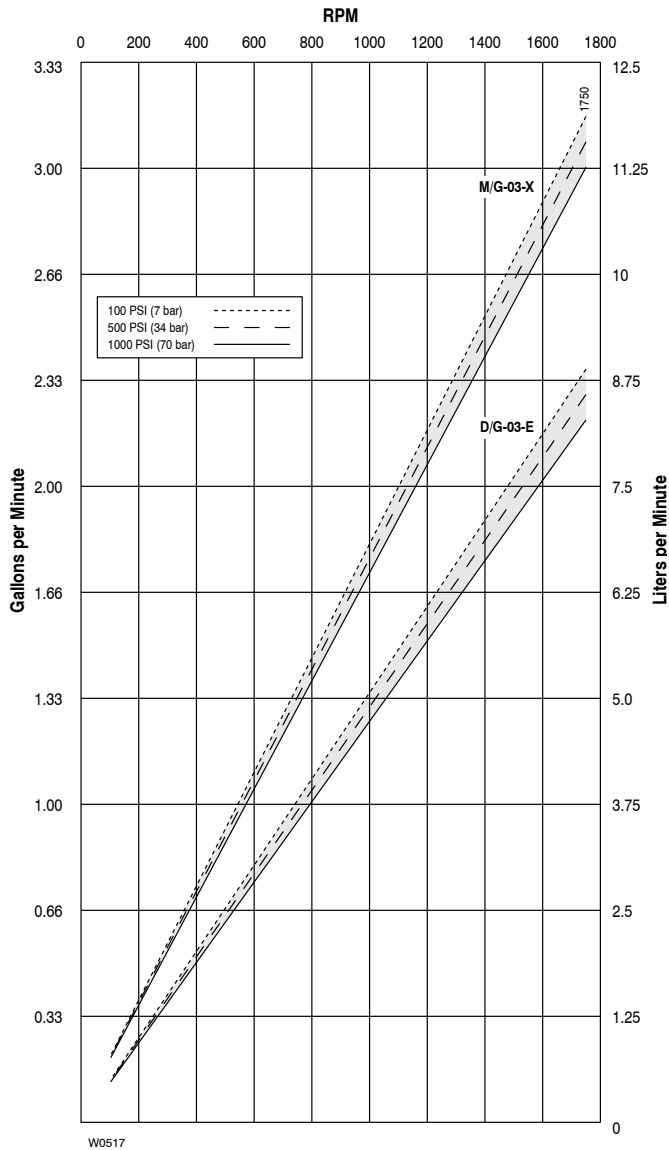

## Net Positive Suction Head – NPSHr

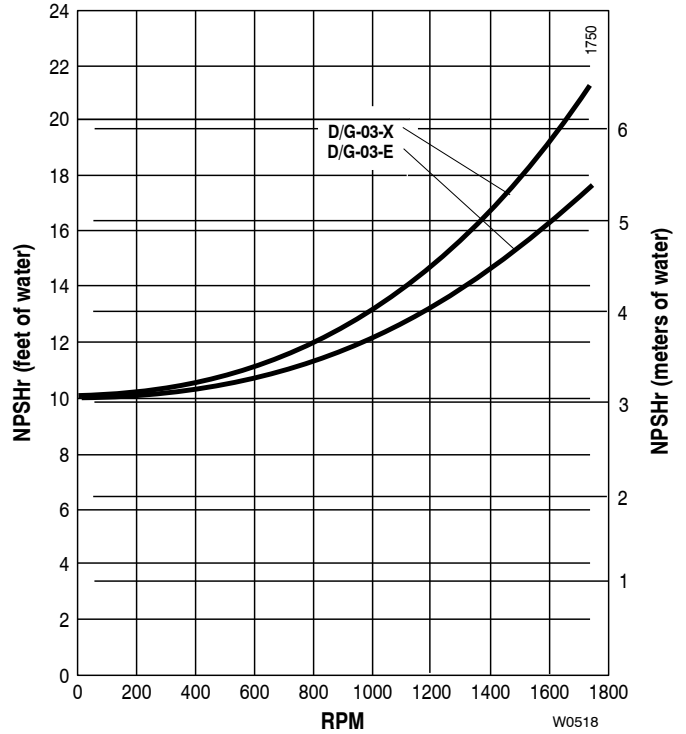

## Dry Lift

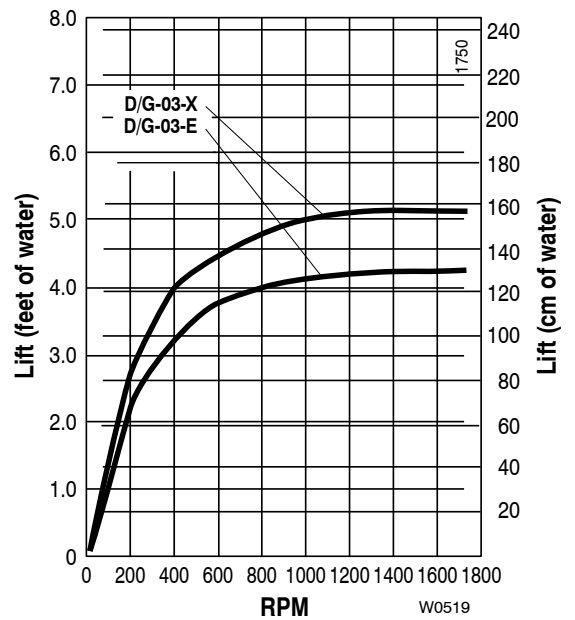

### Note:

Performance and specification ratings apply to all configurations unless specifically noted otherwise. Kel-Cell flow will be about four percent less than that shown in the graph above.

# D/G-03 Mono-Block Dimensions

## M-03/G-13 Mono-Block Models

Brass

316 Stainless Steel

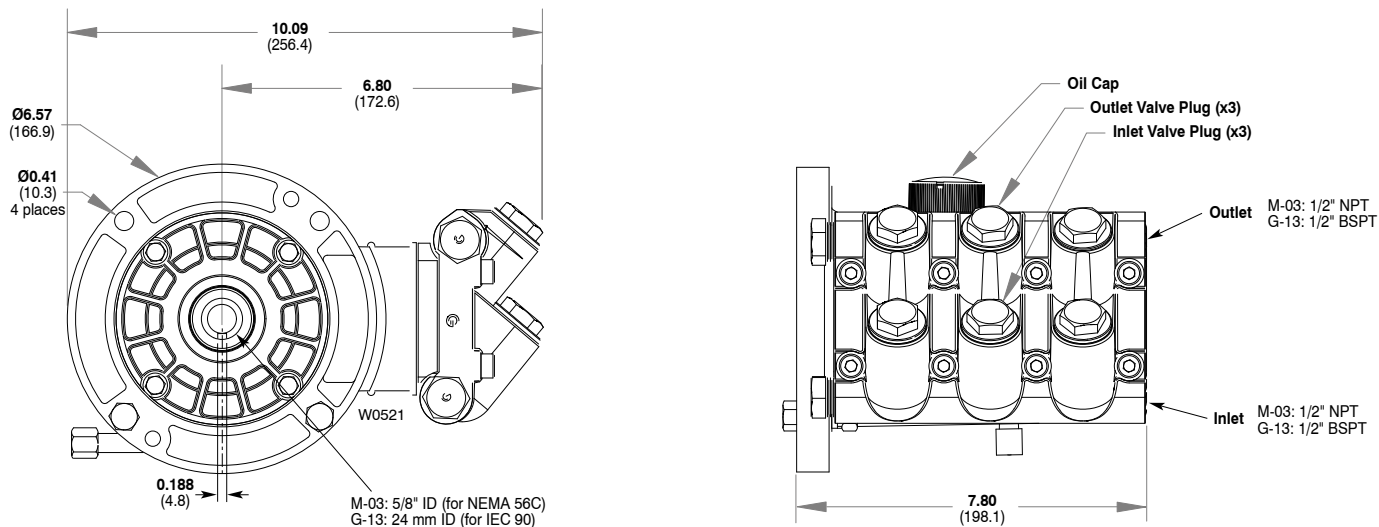

## D-03/G-03 Mono-Block Models

Brass

316 Stainless Steel

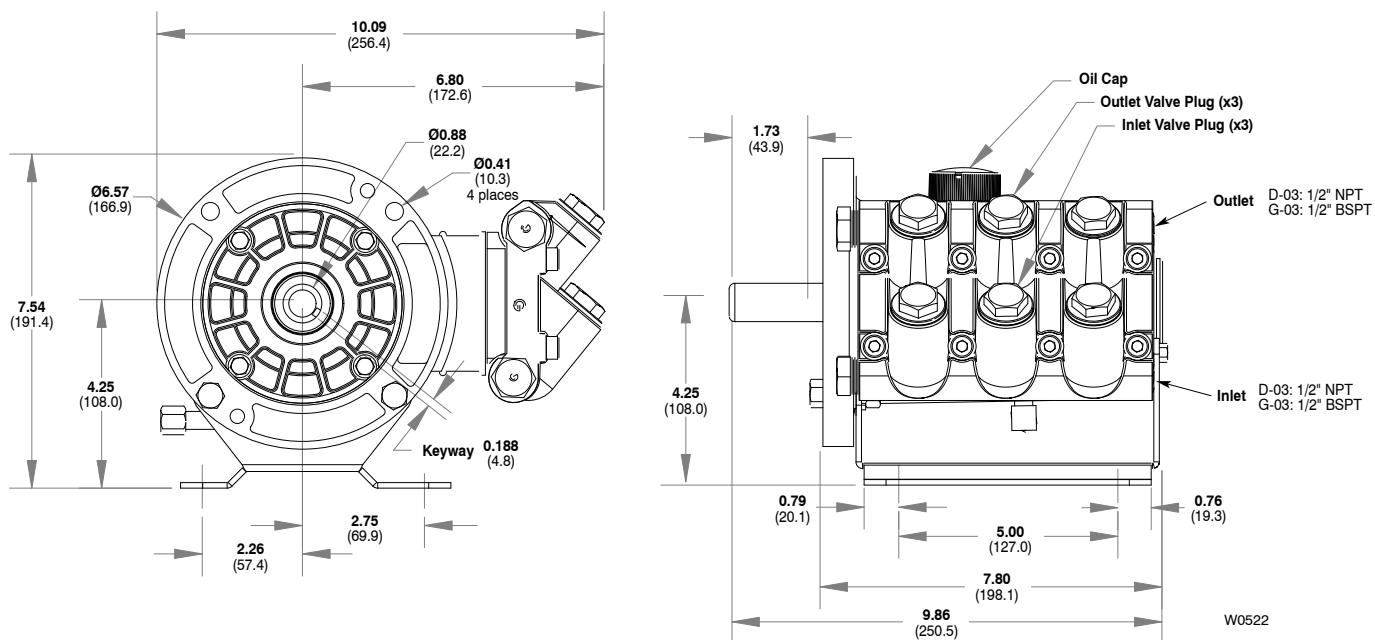

# D/G-03 Mono-Block Dimensions

## M-23 Mono-Block Models

Brass

316 Stainless Steel

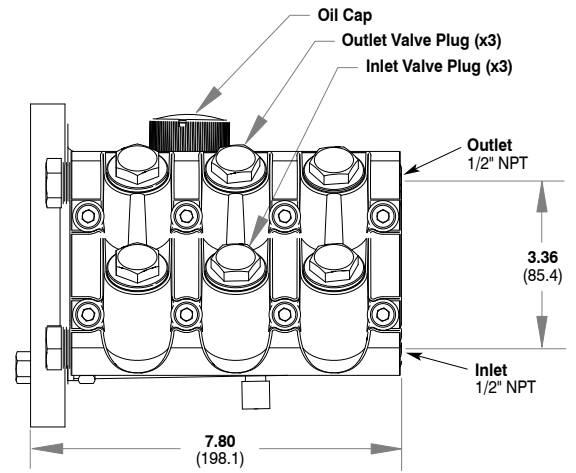
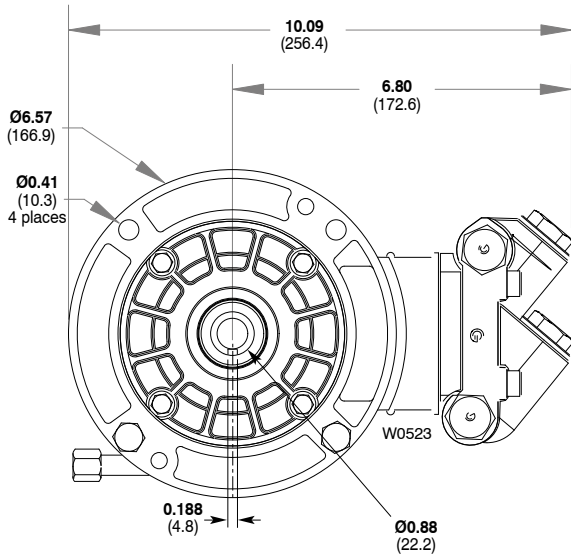

# D/G-03 Mono-Block Installation

**Note:** The numbers in parentheses are the Reference Numbers on the illustrations in the Parts Manual.

## Location

Locate the pump as close to the supply source as possible. Install it in a lighted clean space where it will be easy to inspect and maintain. Allow room for checking the oil level, changing the oil, and removing the pump head (manifold, valve plate and related items).

## Mounting

The pump shaft can rotate in either direction. To prevent vibration, securely attach the pump (D-03, G-03) or motor (M-03, M-23, G-13) to a rigid base.

On a belt-drive system, align the sheaves accurately; poor alignment wastes horsepower and shortens the belt and bearing life. Make sure the belts are properly tightened, as specified by the belt manufacturer.

On a direct-drive system, align the shafts accurately. Unless otherwise specified by the coupling manufacturer, maximum parallel misalignment should not exceed .015in. and angular misalignment should be held to 1 degree maximum. Careful alignment extends life of the coupling, pump, shafts, and support bearings. Consult coupling manufacturer for exact alignment tolerances.

On a close-coupled system, coat the motor shaft liberally with anti-seize.

## Important Precautions

**Adequate Fluid Supply.** To avoid cavitation and premature pump failure, be sure that the pump will have an adequate fluid supply and that the inlet line will not be obstructed. See "Inlet Piping".

**Positive Displacement.** This is a positive-displacement pump. To avoid severe system damage if the discharge line ever becomes blocked, install a relief valve downstream from the pump. See "Discharge Piping".

**Safety Guards.** Install adequate safety guards over all pulleys, belts, and couplings. Follow all codes and regulations regarding installation and operation of the pumping system.

**Shut-Off Valves.** Never install shut-off valves between the pump and discharge pressure regulator, or in the regulator bypass line.

**Freezing Conditions.** Protect the pump from freezing. See also the Maintenance Section.

Consult the Factory for the following situations:

- Extreme temperature applications (above 160° F or below 40° F)
- Pressure feeding of pumps
- Viscous or abrasive fluid applications
- Chemical compatibility problems
- Hot ambient temperatures (above 110° F)
- Conditions where pump oil may exceed 200° F because of a combination of hot ambient temperatures, hot fluid temperature, and full horsepower load — an oil cooler may be required

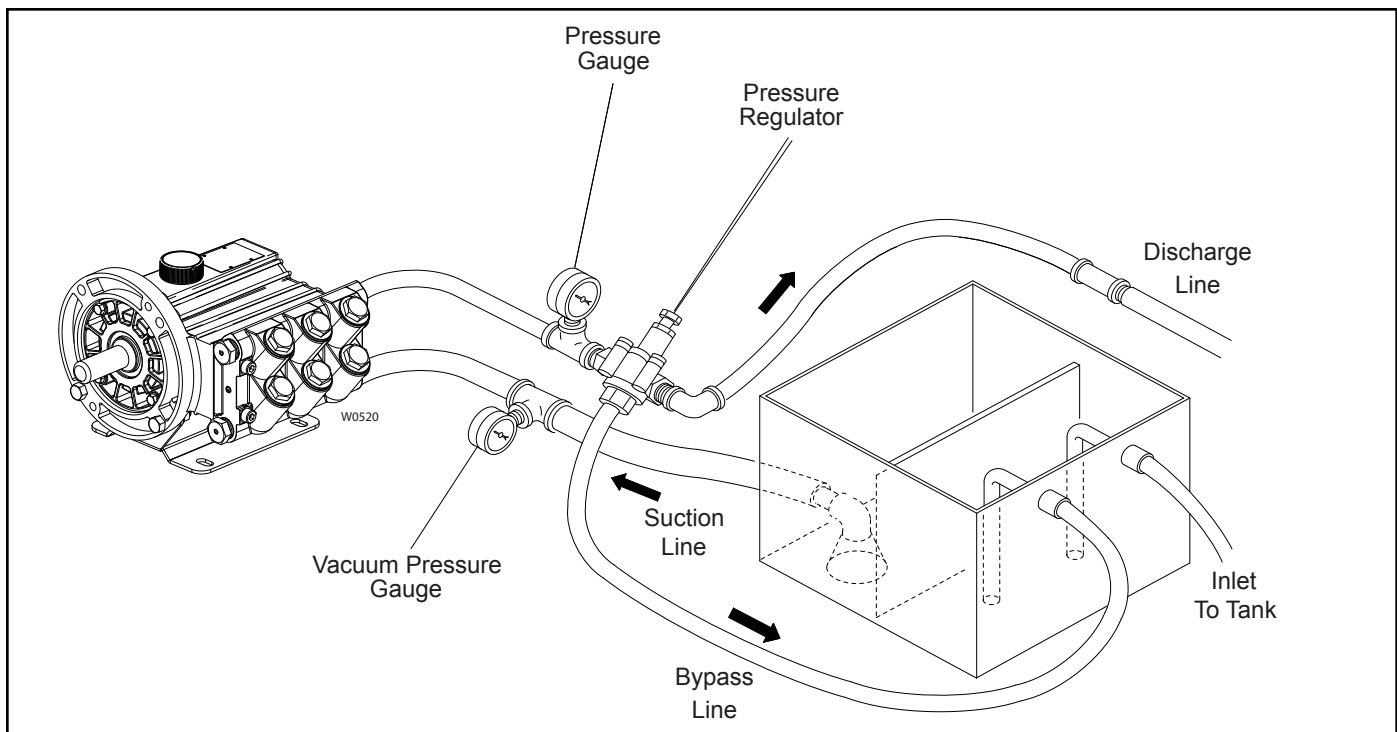

# D/G-03 Mono-Block Installation

## Inlet Piping (Suction Feed)

**Caution: When pumping at temperatures above 160° F (71° C), use a pressure-feed system.**

Install drain cocks at any low points of the suction line, to permit draining in freezing conditions.

Provide for permanent or temporary installation of a vacuum gauge to monitor the inlet suction. To maintain maximum flow, vacuum at the pump inlet should not exceed 7 in. Hg at 3 gpm and 70° F (180 mm Hg at 11.4 liters/min and 21° C). Do **not** supply more than one pump from the same inlet line. With PTFE diaphragms, the inlet must be flooded.

## Supply Tank

Use a supply tank that is large enough to provide time for any trapped air in the fluid to escape. The tank size should be at least twice the maximum pump flow rate.

Isolate the pump and motor stand from the supply tank, and support them separately.

Install a separate inlet line from the supply tank to each pump.

Install the inlet and bypass lines so they empty into the supply tank below the lowest water level, on the opposite side of the baffle from the pump suction line.

If a line strainer is used in the system, install it in the inlet line to the supply tank.

To reduce aeration and turbulence, install a completely submerged baffle plate to separate the incoming and outgoing liquids.

Install a vortex breaker in the supply tank, over the outlet port to the pump.

Place a cover over the supply tank, to prevent foreign objects from falling into it.

## Hose and Routing

Size the suction line at least one size larger than the pump inlet, and so that the velocity will not exceed 1-3 ft/sec (0.3 to 0.9 m/sec):

For pipe in inches:  $\text{Velocity (ft/sec)} = 0.408 \times \text{GPM/Pipe ID}^2$

For pipe in mm:  $\text{Velocity (m/sec)} = 21.2 \times \text{LPM/Pipe ID}^2$

Keep the suction line as short and direct as possible.

Use flexible hose and/or expansion joints to absorb vibration, expansion, or contraction.

If possible, keep the suction line level. Do not have any high points to collect vapor unless these high points are vented.

To reduce turbulence and resistance, do not use 90° elbows. If turns are necessary in the suction line, use 45° elbows or arrange sweeping curves in the flexible inlet hose.

If a block valve is used, be sure it is fully opened so that the flow to the pump is not restricted. The opening should be at least the same diameter as the inlet plumbing ID.

Do not use a line strainer or filter in the suction line unless regular maintenance is assured. If used, it should have a free-flow area of at least three times the free-flow area of the inlet.

Install piping supports where necessary to relieve strain on the inlet line and to minimize vibration.

## Inlet Piping (Pressure Feed)

Provide for permanent or temporary installation of a vacuum/pressure gauge to monitor the inlet vacuum or pressure. Pressure at the pump inlet should not exceed 250 psi (17.3 bar); if it could get higher, install an inlet pressure regulator. Do **not** supply more than one pump from the same inlet line.

## Inlet Calculations

### Acceleration Head

#### Calculating the Acceleration Head

Use the following formula to calculate acceleration head losses. Subtract this figure from the NPSHa, and compare the result to the NPSHr of the Hydra-Cell pump.

$$H_a = (L \times V \times N \times C) \div (K \times G)$$

where:

$H_a$  = Acceleration head (ft of liquid)

$L$  = Actual length of suction line (ft) — not equivalent length

$V$  = Velocity of liquid in suction line (ft/sec) [ $V = \text{GPM} \times (0.408 \div \text{pipe ID}^2)$ ]

$N$  = RPM of crank shaft

$C$  = Constant determined by type of pump — use 0.066 for the M-03, D-03, M-23, G-03 and G-13 Hydra-Cell pumps

$K$  = Constant to compensate for compressibility of the fluid — use: 1.4 for de-aerated or hot water; 1.5 for most liquids; 2.5 for hydrocarbons with high compressibility

$G$  = Gravitational constant (32.2 ft/sec<sup>2</sup>)

### Friction Losses

#### Calculating Friction Losses in Suction Piping

When following the above recommendations (under “inlet Piping”) for minimum hose/pipe I.D. and maximum length, frictional losses in the suction piping are negligible (i.e.,  $H_f = 0$ ) if you are pumping a water-like fluid.

When pumping more-viscous fluids such as lubricating oils, sealants, adhesives, syrups, varnishes, etc., frictional losses in the suction piping may become significant. As  $H_f$  increases, the available NPSH (NPSHa) will decrease, and cavitation will occur.

In general, frictional losses increase with increasing viscosity, increasing suction-line length, increasing pump flow rate, and decreasing suction-line diameter. Changes in suction-line diameter have the greatest impact on frictional losses: a 25% increase in suction-line diameter cuts losses by more than two times, and a 50% increase cuts losses by a factor of five times.

Consult the factory before pumping viscous fluids.

#### Minimizing Acceleration Head and Frictional Losses

To minimize the acceleration head and frictional losses:

- Keep inlet lines less than 3 ft (1 m) long
- Use at least 5/8 in. (16 mm) I.D. inlet hose
- Use soft hose (low-pressure hose, non collapsing) for the inlet lines
- Minimize fittings (elbows, valves, tees, etc.)
- **Use a suction stabilizer on the inlet.**

# D/G-03 Mono-Block Installation

## Net Positive Suction Head

NPSHa must be equal to or greater than NPSHr. If not, the pressure in the pump inlet will be lower than the vapor pressure of the fluid— and cavitation will occur.

### Calculating the NPSHa

Use the following formula to calculate the NPSHa:

$$\text{NPSHa} = P_t + H_z - H_f - H_a - P_{vp}$$

where:

$P_t$  = Atmospheric pressure

$H_z$  = Vertical distance from surface liquid to pump center line (if liquid is below pump center line, the  $H_z$  is negative)

$H_f$  = Friction losses in suction piping

$H_a$  = Acceleration head at pump suction

$P_{vp}$  = Absolute vapor pressure of liquid at pumping temperature

### Notes:

- In good practice, NPSHa should be 2 ft greater than NPSHr
- All values must be expressed in feet of liquid

### Atmospheric Pressure at Various Altitudes

Altitude (ft)	Pressure (ft of H <sub>2</sub> O)	Altitude (ft)	Pressure (ft of H <sub>2</sub> O)
0	33.9	1500	32.1
500	33.3	2000	31.5
1000	32.8	5000	28.2

## Discharge Piping

**Note: Consult the Factory before manifolding two or more pumps together.**

### Hose and Routing

Use shortest, most-direct route for discharge line.

Select pipe or hose with **working pressure** rating of at least 1.5 times maximum system pressure. EXAMPLE: Select 1500 psi (103 bar) W.P. rated hose for systems to be operated at 1000 psi (69 bar) gauge pressure.

Use about 6 ft (1.8 m) of flexible hose between pump and rigid piping to absorb vibration, expansion or contraction.

Support pump and piping independently. Size discharge line so that velocity of fluid will not exceed 7-10 ft/sec (2-3 m/sec):

For pipe in inches: Velocity (ft/sec) =  $0.408 \times \text{GPM}/\text{Pipe ID}^2$

For pipe in mm: Velocity (m/sec) =  $21.2 \times \text{LPM}/\text{Pipe ID}^2$

### Pressure Regulation

**Install pressure regulator or unloader in discharge line.**

Bypass pressure must not exceed pressure limit of pump.

Size regulator so that, when fully open, it will be large enough to relieve full capacity of pump without over pressurizing the system.

Locate regulator as close to pump as possible and ahead of any other valves.

Adjust pressure regulator valve to no more than 10% over maximum working pressure of system. Do not exceed

manufacturer's pressure rating for pump or regulator.

Route bypass line to supply tank, or to suction line as far as possible from pump (to reduce chance of turbulence).

If pump will be operating for long time with discharge closed and fluid bypassing, install thermal protector set to trip at 140° F in bypass line (to prevent severe temperature buildup in bypassed fluid).

**CAUTION: Never install shutoff valves in the bypass line or between the pump and pressure regulator or relief valve.**

Provide for permanent or temporary installation of pressure gauge to monitor discharge pressure at pump.

For additional system protection install safety relief valve in discharge line downstream from pressure regulator.

## Before Initial Start-Up

Before you start the pump, be sure that:

- All shut-off valves are open, and pump has adequate supply of fluid.
- All connections are tight.
- Oil level is 3/4 in. (20 mm) from top of fill port
- Relief valve on outlet of pump is adjusted so pump starts under minimum pressure.
- All pulleys and belts are properly aligned, and belts are tensioned according to specification.
- All pulleys and belts have adequate safety guards.

## Initial Start-Up Procedure

1. Turn on power to pump motor.
2. Check inlet pressure or vacuum. To maintain maximum flow, inlet vacuum must not exceed 7 in. Hg at 70° F (180 mm Hg at 21° C). Inlet pressure must not exceed 250 psi (17.3 bar).
3. Listen for any erratic noise and look for unsteady flow.
4. If system has air lock and pump fails to prime:
  - a. Turn off power.
  - b. Open one outlet port.
  - c. Briefly restart system and operate until fluid comes out outlet port.
  - d. Turn off power and reinstall outlet port plug.
5. Adjust discharge pressure regulator to desired operating and bypass pressures. Do not exceed maximum pressure rating of pump.
6. After pressure regulator is adjusted, set "pop-off" safety relief valve at 100 psi (6.9 bar) higher than desired operating pressure.



# D/G-03 Mono-Block Maintenance

**Note:** The numbers in parentheses are the Ref. Nos. on the illustrations in the Parts Manual.

## Daily

Check oil level and condition of oil. Oil level should be 3/4 in. (20 mm) from top of fill port.

Use correct Wanner Hydra-Oil brand motor oil for application (contact Wanner Engineering if in doubt).

**Caution:** If you are losing oil but don't see any external leakage, or if the oil becomes discolored and contaminated, one of the diaphragms (17) may be damaged. Refer to the Service Section. Do not operate the pump with a damaged diaphragm.

**Caution:** Do not leave contaminated oil in the pump housing or leave the housing empty. Remove contaminated oil as soon as discovered, and replace it with clean oil.

## Periodically

Change oil after first 100 hours of operation, then change according to guidelines below. When changing, remove drain plug (60). Allow all oil and contaminant to drain out.

### Hours Between Oil Changes @ Various Process Fluid Temperatures

Pressure	RPM	<90°F (32°C)	<139°F (60°C)	<180°F (82°C)
<b>Metallic Pump Head</b>				
<800 psi (55 bar)	<1200	8,000	5,000	3,000
	<1800	4,000	3,000	2,000
<1000 psi (69 bar)	<1200	4,000	3,000	2,000
	<1800	2,000	1,500	1,000
<b>Non-Metallic Pump Head</b>				
<250 psi (17 bar)	<1200	4,000	3,000	—
	<1800	2,000	1,500	—

**Note:** Minimum oil viscosity for proper hydraulic end lubrication is 16-20 cST (80-100 SSU).

**CAUTION:** Do not turn the drive shaft while the oil reservoir is empty.

Use correct Hydra-Oil for application (contact Wanner Engineering if in doubt).

**CAUTION:** If you are losing oil but don't see any external leakage, or if the oil becomes discolored and contaminated, the diaphragm (17) may be damaged. Refer to the Fluid-End Service Section. Do not operate the pump with a damaged diaphragm.

**CAUTION:** Do not leave contaminated oil in the pump housing or leave the housing empty. Remove contaminated oil as soon as discovered, and replace it with clean oil.

Check inlet pressure or vacuum periodically with gauge.

**CAUTION:** Protect the pump from freezing. Refer also to the "Shutdown Procedure".

## Shutdown Procedure During Freezing Temperatures

Take all safety precautions to assure safe handling of the fluid being pumped. Provide adequate catch basins for fluid drainage and use correct plumbing from drain ports, etc. when flushing the pump and system with a compatible antifreeze.

1. Adjust discharge pressure regulating valve so pump runs under minimum pressure. Stop pump.
2. Drain supply tank; open any draincocks in system piping and collect drainage; remove plugs from manifold and collect drainage.
3. Close draincocks in system piping and replace manifold plugs.
4. Fill supply tank with enough antifreeze to fill system piping and pump.

**Note:** disconnect the system return line from the supply tank and connect it to a separate reservoir.

5. Start pump and allow to run until system is filled with antifreeze.

**Note:** if the system has an air lock and the pump fails to prime, follow step 4 of the Initial Start-up Procedure to clear the air.

6. When mostly antifreeze is flowing from system return line stop pump. Connect system return line back to supply tank and circulate antifreeze for short period.
7. It is good practice to change oil in Hydraulic End before storage for extended period. This will remove any accumulated condensation and sediment from oil reservoir. Drain and refill Hydraulic End with correct Hydra-Oil and operate pump for short period to assure smooth performance.

# D/G-03 Mono-Block Fluid End Service

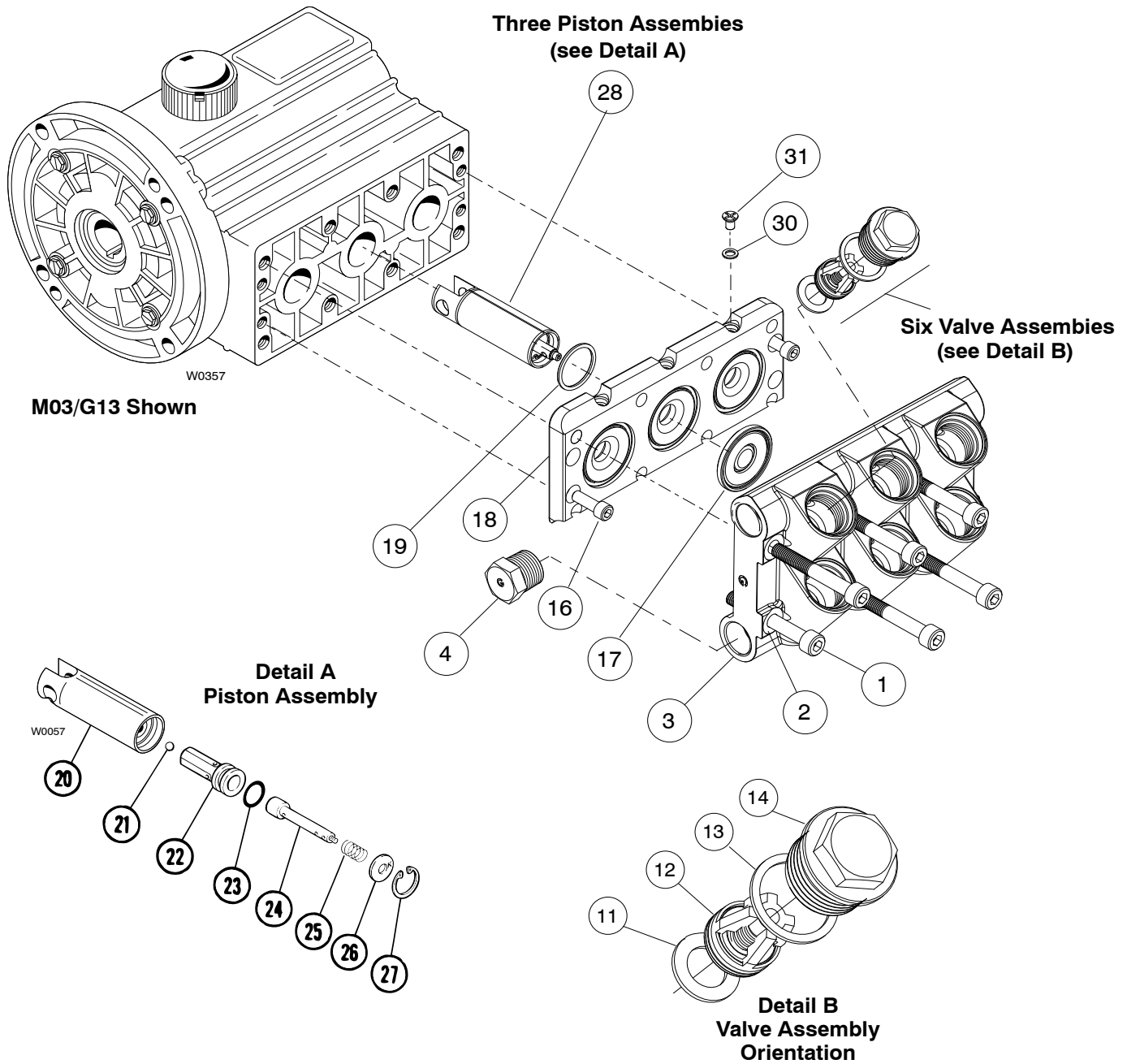

## Bolt Torque Specifications

Ref. No.	Assembly Torque
1	15 ft-lbs/20 Nm
14	Hand tight

# D/G-03 Mono-Block Fluid End Service

This section explains how to disassemble and inspect all easily-serviceable parts of the pump. Repair procedures for the hydraulic end (oil reservoir) of the pump are included in a later section of the manual.

**Caution:** Do not disassemble the Hydraulic End unless you are a skilled mechanic. For assistance, contact Wanner Engineering (Tel 612-332-5681 or Fax 612-332-6937) or the distributor in your area.

**Note:** The numbers in parentheses are the Ref. Nos. on the illustrations in the Parts Manual.

## Special Tools

Valve Removal Tool: D03-086-2010, 1/4-20 X 1.5 inches long, ST Screw.

## 1. Remove Outlet and Inlet Valve Assemblies (12)

- Remove six plugs (14) and O-rings (13).
- Using needle nose pliers, grab valve assembly (12) across flats of valve retainer (10) and rock back and forth to loosen seat (6).
- Continue pulling valve retainer outward until it comes out.
- Using pick, pull out damping washer (11).
- Remove remaining five valve assemblies using steps b, thru d.

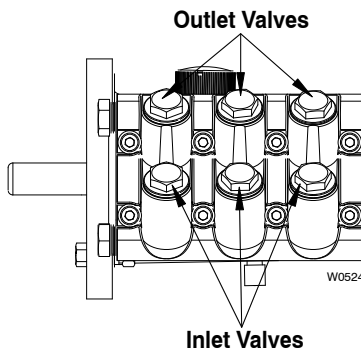

## 2. Inspect Valve Assembly (12)

The three outlet and three inlet valve assemblies (12) are identical. Inspect valve assembly parts as follows:

- Check for worn spring retainer.
  - Check valve spring compression.
  - Check valve poppet for excessive wear.
  - Check valve seat for wear.
  - If any valve parts are worn, replace valve assembly.
  - Check dampening washer (11), and replace if worn.
  - Reinstall valve assemblies:
    - Clean valve ports and shoulders with emery cloth, and lubricate with lubricating gel or petroleum jelly.
- Note:** Outlet and Inlet Valves install the same way. See Detail B in Parts View.
- Insert valve assembly (12) into port and tap on top of valve retainer until valve seats. Insert O-ring (13) on plug (14) and turn all the way in. Hand tighten.

## 3. Remove Manifold (3)

- Remove eight bolts (1) attaching manifold.
  - Remove manifold (3).
  - Inspect manifold for warping or wear around diaphragm pockets. If wear is excessive, replace manifold.
- To check if manifold is warped, place straightedge across it. A warped manifold should be replaced.

# D/G-03 Mono-Block Fluid End Service

---

## 4. Inspect and Replace Diaphragms (17)

- a. Lift diaphragm (17) by one edge, and turn pump shaft until diaphragm moves up to “top dead center”. This will expose machined cross holes in plunger shaft behind diaphragm.

**Note: If the pump has a hollow shaft, use the shaft rotator from the Wanner Tool Kit to turn the shaft.**

- b. Remove three flat-hd screws (31) and O-rings (30) from edge access holes in diaphragm plate (18). Insert 3/32 in. hex wrench (A03-163-2200) into one of holes in diaphragm plate (18). Turn and pull diaphragm (17) until front cross hole in valve plunger spool (24) lines up and allows hex wrench to pass through. (Don't remove hex wrench until new diaphragm is installed in step “g” below.)
- c. Unscrew diaphragm. Use 5/16 in. (8 mm) open-end wrench, and turn counterclockwise.
- d. Inspect diaphragm carefully. A ruptured diaphragm generally indicates pumping system problem, and replacing only diaphragm will not solve larger problem. Inspect diaphragm for following:
  - **Small puncture.** Usually caused by sharp foreign object in fluid, or by ice particle.
  - **Diaphragm pulled away** from sides. Usually cause by fluid being frozen in pump, or by over pressurization of pump.
  - **Diaphragm becoming stiff** and losing flexibility. Usually caused by pumping fluid that is incompatible with diaphragm material.
  - **Diaphragm edge chewed away.** Usually caused by over pressurizing system.

**Caution: If a diaphragm has ruptured and foreign material or water has entered the oil reservoir, do not operate the pump. Check all diaphragms, then flush the reservoir completely (as outlined below) and refill it with fresh oil. Never let the pump stand with foreign material or water in the reservoir, or with the reservoir empty.**
- e. Clean away any spilled oil. Apply Loctite No. 242 Threadlocker to screw of new diaphragm (or old one, as appropriate).
- f. Install diaphragm and tighten to 10 in-lbs (110 N-cm).
- g. Repeat above inspection procedure (and replacement, if necessary) with other two diaphragms.

## 5. Flush Contaminant from Hydraulic End

### (Only if diaphragm has ruptured)

- a. With valve plate and manifold still removed (see above), remove oil drain cap (60) and allow all oil and contaminant to drain out.

**Caution: If you have EPDM diaphragms, or if food grade oil is in the reservoir, flush with the same lubricant that is in the reservoir. Pumps with EPDM diaphragms have an “E” as the 7th digit of the Model No.**
- b. Fill reservoir with fresh oil, manually turn pump shaft to circulate oil, and drain once again.
- c. Refill reservoir. If oil appears milky, there is still contaminant in reservoir. Repeat flushing procedure until oil appears clean.

## 6. Reinstall Manifold (3)

- a. Reinstall manifold (3) onto diaphragm plate (18).
- b. Insert all bolts (1), with washers (2), around edge of manifold, and alternately tighten opposite bolts until all are secure. Torque to 15 ft-lbs (20 N-m).
- c. Recheck all bolts for tightness.

# D/G-03 Mono-Block Fluid End Service

---

## 7. Prime Hydraulic Cells

- a. With pump **horizontal**, fill reservoir with correct Hydra oil for application.
- b. All air in oil within hydraulic cell (behind diaphragms) must be forced out by turning shaft (this pumps piston). Shaft rotator is included in Wanner Tool Kit.

Turn or jog shaft until **blubble-free** flow of oil comes out of each access hole in diaphragm plate (18). Watch oil level in reservoir; if it gets too low during priming, air will be drawn into pistons (inside hydraulic end). This will cause pump to run rough, and will require re-priming hydraulic cells.

Reinstall flat-hd screw (31) and O-ring (30) for each access hole as they are primed.

# D/G-03 Mono-Block Hydraulic End Service

## G-13 Pump Housing

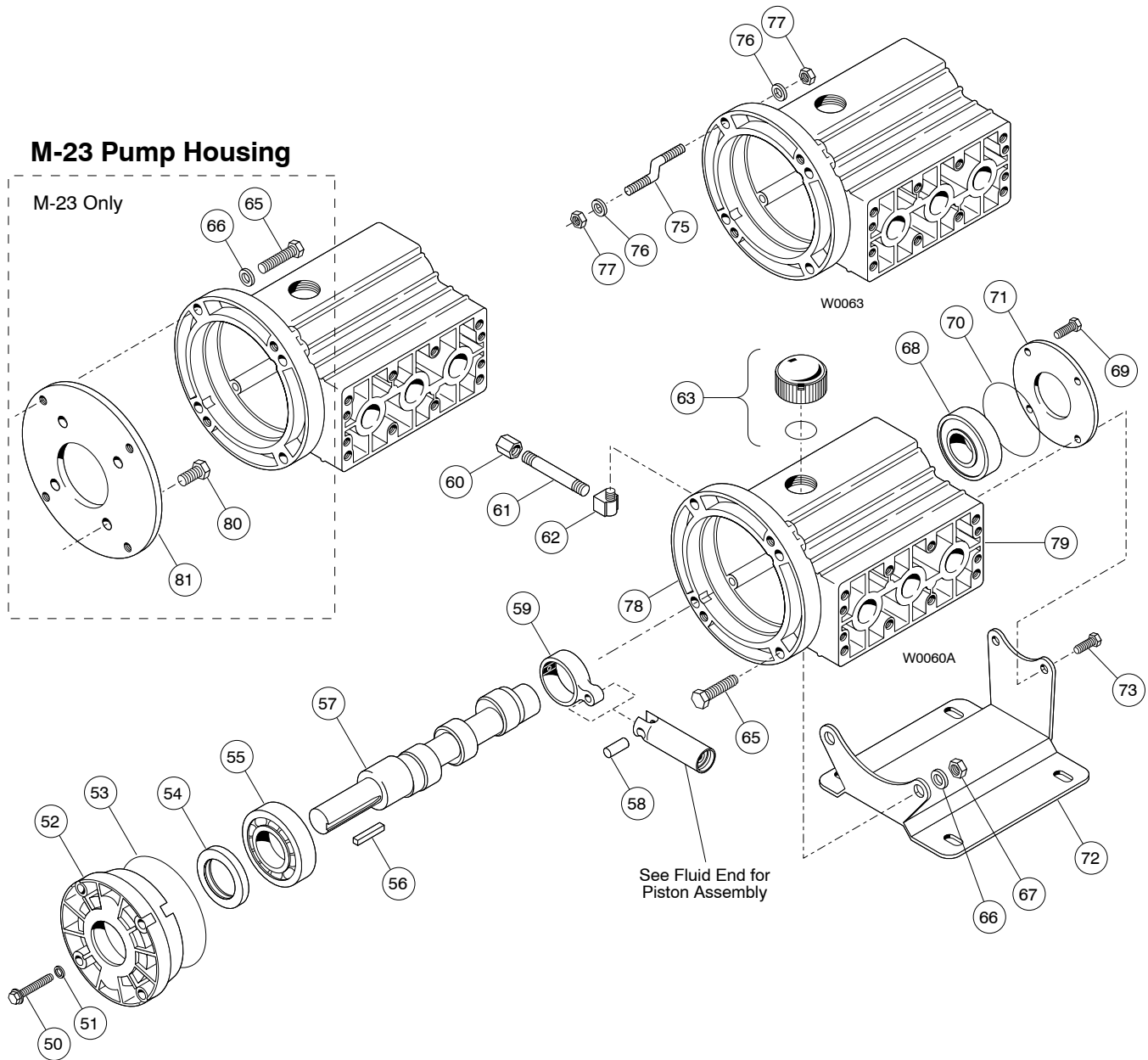

## D/G-03 Pump/ Motor Adapter

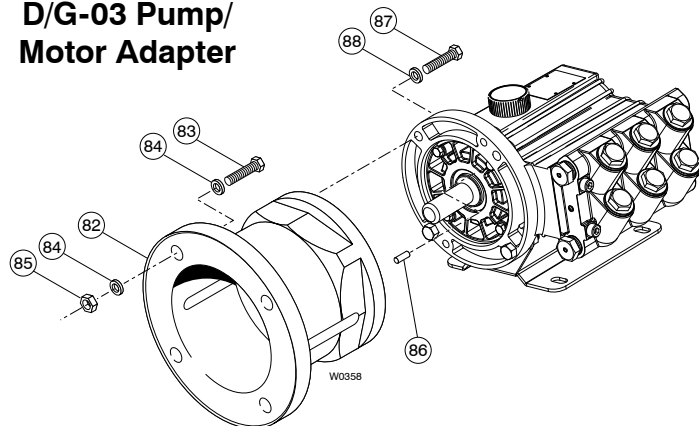

# D/G-03 Mono-Block Hydraulic End Service

**Note:** The numbers in parentheses are the Ref. Nos. on the illustrations in the Parts Manual.

This section explains how to disassemble and inspect the hydraulic end (oil reservoir) of the pump.

**Caution:** Do not disassemble the hydraulic end unless you are a skilled mechanic. For assistance, contact Wanner Engineering (Tel 612-332-5681 or Fax 612-332-6937) or the distributor in your area.

Depending on the repair you are attempting, you may or may not have to remove the motor from a direct-drive pump/motor unit.

Internal piston components (21 - 27) can be serviced without removing the motor or crankshaft. The motor and crankshaft must be removed to service the connecting rod (59), piston housing (20), crankshaft (57), front bearing (68), back bearing (55), or seal (54).

## To Service Pistons Without Removing Motor or Crankshaft

### 1. Disassemble Pistons

With the manifold, valve plate, diaphragm plate, and diaphragm removed, and the oil drained from the pump (see the Fluid End Service Section):

- Remove snap ring (27) from one of pistons, using standard snap-ring pliers.
- Pull out valve plunger (24). This also removes washer (26) and spring (25).
- Insert hook through center hole of valve cylinder (22), and pull cylinder out of piston. Be careful not to damage piston.
- Inspect all parts, and replace O-ring and any other parts that are worn or may be damaged.
- Repeat steps a. through d. for remaining pistons.

### 2. Reassemble Pistons

- Tip pump so pistons are vertical.
- Drop ball (21) into opening in bottom of piston.
- Insert valve plunger (24) into valve cylinder (22). Slide spring (25) over plunger, inside valve cylinder.
- Slide assembled valve cylinder, plunger, and spring (22 - 25) into piston (20).
- Insert washer (26) over plunger.
- Insert snap ring (27) into piston. Use snap-ring pliers.
- Repeat above procedure for other two pistons.

## To Remove Motor from Direct-Coupled Unit

### 1. Disassemble Motor from Pump

- M-03.** Remove four bolts (65) and washers (66) that secure pump and motor together.  
**M-23.** Remove four bolts (65) and washers (66) that secure pump and adapter plate (81) together.  
**G-13.** Remove four nuts (77) and washers (76) from motor side of offset stud (75).
- M-03, M-23.** Install two of bolts into threaded holes in rear of pump housing.  
**G-13.** Install two M10 x 1.5 x 40 mm (65) or longer bolts into threaded holes in rear flange of pump housing.
- Alternately turn bolts clockwise until pump and motor separate.

### 2. Reassemble Motor to Pump

- Thoroughly clean motor shaft and hollow pump shaft. Remove tape from key and keyway.
- Apply generous amount of Loctite® Nickel Anti-Seize No. 77164 to pump shaft.
- Install shaft key (56) into keyway.
- Slide motor shaft into hollow pump shaft.

**Caution:** When assembling this pump to the direct-coupled motor, be careful that the shaft key remains in the motor shaft keyway and does not ride up the keyway and contact the shaft seals (which would cause premature seal failure). Incorrect key placement could also cause the hollow pump shaft to fail.

**Use a screwdriver to move the shaft key back in the motor shaft keyway as the motor and pump are drawn together.**

- M-03, M-23.** Reinstall four bolts (65) and washers (66).  
**G-13.** Reinstall four washers (76) and nuts (77).

# D/G-03 Mono-Block Hydraulic End Service

---

## *To Service Remainder of Hydraulic End*

### 1. Remove Pump Housing

- a. Remove manifold, valve plate, and diaphragms, as outlined in Fluid End Service Section.
- b. Drain oil from pump housing by removing drain plug (60).
- c. Stand pump on end, with drive shaft up.
- d. Remove bolts (50) that secure back cover (52) to housing (78). Use 3/8 in. socket wrench (10-mm on M-03/G-03 and G-13). Save O-rings (51).
- e. Remove cover and cover O-ring (53).
- f. Remove crankshaft (57) by pulling it through connecting rods (59).

### 2. Remove and Replace Pistons

To remove pistons (20), first remove connecting rod (59) and pin (58) by pressing pin through connecting rod.

Reverse process to reinstall pistons.

Go to Step 5 to replace diaphragm and reassemble pump.

### 3. Replace Shaft Seal

**Note: Inspect the shaft seal (54) before continuing. If it looks damaged in any way, replace it.**

- a. Press back bearing (55) and seal (54) out of back cover (52). Discard seal.
- b. Apply coating of Loctite® High-Performance Pipe Sealant with PTFE, or comparable product, to outer surface of new seal and inside surface of opening in back cover (52) where seal will rest.
- c. Press new seal into back cover.
- d. Inspect bearing (55). Replace if pitted or damaged.
- e. Apply coating of Loctite Rc/609 Retaining Compound or comparable product to outer surface of bearing. Press bearing into back cover until it rests on shoulder. Shield on bearing must face away from back cover.

### 4. Reassemble Housing and Back Cover

- a. Stand pump on end.
- b. With pistons and connecting rods in place, reinstall crankshaft by threading it through connecting rods.
- c. Reinstall back cover (52), cover O-ring (53), and bolts (with their O-rings).

### 5. Reassemble Pump

Reassemble pump as outlined in Fluid-End Service Section.



# D/G-03 Mono-Block Troubleshooting

---

## Cavitation

- Inadequate fluid supply because:
  - Inlet line collapsed or clogged
  - Clogged line strainer
  - Inlet line too small or too long
  - Air leak in inlet line
  - Worn or damaged inlet hose
  - Suction line too long
  - Too many valves and elbows in inlet line
- Fluid too hot for inlet suction piping system.
- Air entrained in fluid piping system.
- Aeration and turbulence in supply tank.
- Inlet vacuum too high (refer to “Inlet Calculations”, page 3).

## Symptoms of Cavitation

- Excessive pump valve noise
- Premature failure of spring or retainer
- Volume or pressure drop
- Rough-running pump
- Premature failure of diaphragms

## Drop in Volume or Pressure

A drop in volume or pressure can be caused by one or more of the following:

- Air leak in suction piping
- Clogged suction line or suction strainer
- Suction line inlet above fluid level in tank
- Inadequate fluid supply
- Pump not operating at proper RPM
- Relief valve bypassing fluid
- Worn pump valve parts
- Foreign material in inlet or outlet valves
- Loss of oil prime in cells because of low oil level
- Ruptured diaphragm
- Cavitation
- Warped manifold from over pressurized system
- O-rings forced out of their grooves from over pressurization
- Air leak in suction line strainer or gasket
- Cracked suction hose.
- Empty supply tank
- Excessive aeration and turbulence in supply tank
- Cavitation
- Abrasives in the fluid
- Valve incompatible with corrosives in the fluid
- Pump running too fast
- Worn and slipping drive belt(s)
- Worn spray nozzle(s)

## Pump Runs Rough

- Worn pump valves
- Air lock in outlet system
- Oil level low
- Wrong weight of oil for cold operating temperatures (change to lighter weight)
- Cavitation
- Air in suction line
- Restriction in inlet/suction line
- Hydraulic cells not primed after changing diaphragm
- Foreign material in inlet or outlet valve
- Damaged diaphragm
- Fatigued or broken valve spring

## Premature Failure of Diaphragm

- Frozen pump
- Puncture by a foreign object
- Elastomer incompatible with fluid being pumped
- Pump running too fast
- Excess pressure
- Cavitation

## Water (or Process Fluid) in Oil Reservoir

- Condensation
- Ruptured diaphragm
- Hydraulic cell not properly primed after diaphragm replacement
- Frozen pump

## Strong Water (or Process Fluid) Pulsations

**Note: Small pulsations are normal in single-acting pumps with multiple pumping chambers.**

- Foreign object lodged in pump valve
- Loss of prime in hydraulic cell because of low oil level
- Air in suction line
- Valve spring broken
- Cavitation
- Aeration or turbulence in supply tank

# D/G-03 Mono-Block Troubleshooting

---

## Valve Wear

- Normal wear from high-speed operation
- Cavitation
- Abrasives in the fluid
- Valve incompatible with corrosives in the fluid
- Pump running too fast

## Loss of Oil

- External seepage
- Rupture of diaphragm
- Frozen pump
- Worn shaft seal
- Oil drain piping or fill cap loose.
- Valve plate and manifold bolts loose
- Pump housing porosity

## Premature Failure of Valve Spring or Retainer

- Cavitation
- Foreign object in the pump
- Pump running too fast
- Spring/retainer material incompatible with fluid being pumped
- Excessive inlet pressure.

# D/G-03 Mono-Block Warranty

---

## Limited Warranty

Wanner Engineering, Inc. extends to the original purchaser of equipment manufactured by it and bearing its name, a limited one-year warranty from the date of purchase against defects in material or workmanship, provided that the equipment is installed and operated in accordance with the recommendations and instructions of Wanner Engineering, Inc. Wanner Engineering, Inc. will repair or replace, at its option, defective parts without charge if such parts are returned with transportation charges prepaid to Wanner Engineering, Inc., 1204 Chestnut Avenue, Minneapolis, Minnesota 55403.

This warranty does not cover:

1. The electric motors (if any), which are covered by the separate warranties of the manufacturers of these components.
2. Normal wear and/or damage caused by or related to abrasion, corrosion, abuse, negligence, accident, faulty installation or tampering in a manner which impairs normal operation.
3. Transportation costs.

This limited warranty is exclusive, and is in lieu of any other warranties (express or implied) including warranty of merchantability or warranty of fitness for a particular purpose and of any non contractual liabilities including product liabilities based on negligence or strict liability. Every form of liability for direct, special, incidental or consequential damages or loss is expressly excluded and denied.



***WANNER ENGINEERING, INC.***

**1204 Chestnut Avenue, Minneapolis, MN 55403  
TEL: (612) 332-5681 FAX: (612) 332-6937  
TOLL-FREE FAX [US only]: (800) 332-6812**

**[www.hydra-cell.com](http://www.hydra-cell.com)  
email: [sales@wannereng.com](mailto:sales@wannereng.com)**