

# F/G-20 Series

*Up to 1.0 gpm (3.8 l/min)*



**F/G-20** hollow shaft for close coupling with NEMA C-Face and IEC B5 Flange motors

**F/G-22** with Pump/Motor Adapter for coupling to NEMA C-Face and IEC B5 Flange motors

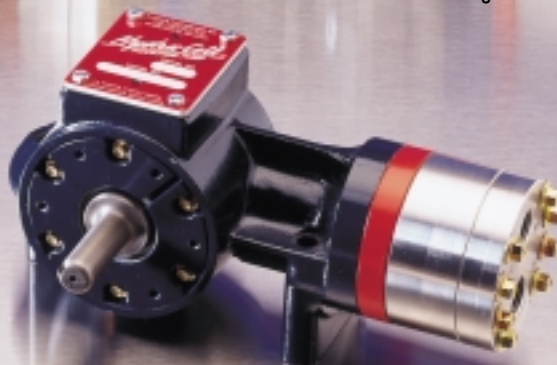

**F/G-21** shaft-driven

*Hydra-Cell*<sup>®</sup>  
SIMPLY BUILT TO LAST

# F/G-20 Series Performance

## flow

model*	max flow		max input rpm
	gpm	l/min	
<b>F/G-20-X</b>	0.96	3.63	1750
<b>F/G-20-E</b>	0.73	2.76	1750
<b>F/G-20-S</b>	0.55	2.08	1750
<b>F/G-20-B</b>	0.33	1.25	1750
<b>F/G-20-G</b>	0.20	0.76	1750

## pressure

### Maximum Inlet Pressure:

100 psi (7 bar)

### Maximum Pressure:

#### Metallic Pump Heads:

F/G-20: 1000 psi (70 bar)

F/G-21: 1500 psi (100 bar)

F/G-22: 1500 psi (100 bar)

#### Non-Metallic Pump Heads:

All Models: 250 psi (17 bar)

### \* Note

Performance and specification ratings apply to all configurations unless specifically noted otherwise.

### Calculating Required Horsepower (kW)\*\*

$$\frac{5.5 \times \text{rpm}}{63,000} + \frac{\text{gpm} \times \text{psi}}{1,460} = \text{electric motor HP}$$

$$\frac{5.5 \times \text{rpm}}{84,428} + \frac{\text{lpm} \times \text{bar}}{511} = \text{electric motor kW}$$

\*\*rpm equals pump shaft rpm. HP/kW is required application power. Use caution when sizing motors with variable speed drives.

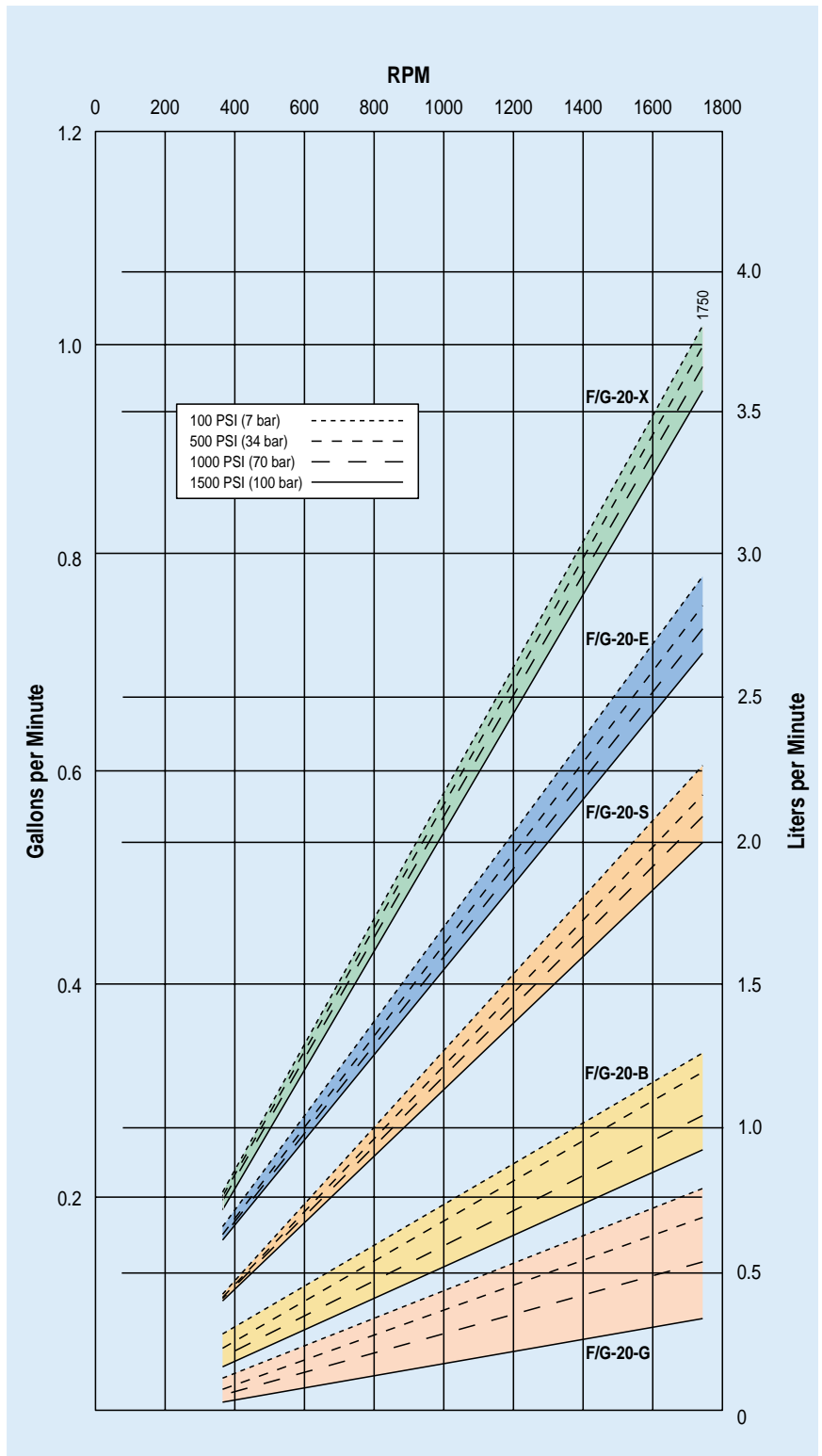

# F/G-20 Series Specifications

## Max Pressure\*

Metallic Heads: F/G-20: 1000 psi (70 bar);  
F/G-21 & F/G-22: 1500 psi (100 bar)  
Non-Metallic Heads: All Models: 250 psi (17 bar)

## Capacity @ Max Pressure\*

	rpm	gpm	l/min
F/G-20-X	1750	0.96	3.63
F/G-20-E	1750	0.73	2.76
F/G-20-S	1750	0.55	2.08
F/G-20-B	1750	0.33	1.25
F/G-20-G	1750	0.20	0.76

## Delivery @ Max Pressure\*

	revs/gal	revs/liter
F/G-20-X	1823	500
F/G-20-E	2397	659
F/G-20-S	3182	906
F/G-20-B	5303	1400
F/G-20-G	8750	2302

**Max Inlet Pressure** 100 psi (7 bar)

## Max Temperature

Metallic Heads: 250°F (121°C) – Consult factory for correct component selection for temperatures above 160°F (71°C)  
Non-Metallic Heads: 140°F (60°C)

**Inlet Port** F-20/21/22: 1/2 inch NPT  
G-20/21/22: 1/2 inch BSPT

**Discharge Port** F-20/21/22: 3/8 inch NPT  
G-20/21/22: 3/8 inch BSPT

**Shaft Diameter** F-20: 5/8 inch hollow shaft for NEMA 56C C-Face motor (with feet)  
F-21: 5/8 inch shaft driven\*  
F-22: 5/8 inch\*  
G-20: 19 mm for IEC 80 B5 Flange motor (with feet)  
G-21: 19 mm shaft driven\*  
G-22: 19 mm shaft driven\*  
\*Refer to Pump/Motor Adapter section

**Shaft Rotation** Bi-directional

**Bearings** Ball bearings

**Oil Capacity** 1/8 US quart (0.12 liters), see Accessories Section for oil selection and specification.

## Weight

Metallic Heads: 12 lbs (5.5 kg)  
Non-Metallic Heads: 9 lbs (4.1 kg)

## Net Positive Suction Head (NPSHr)

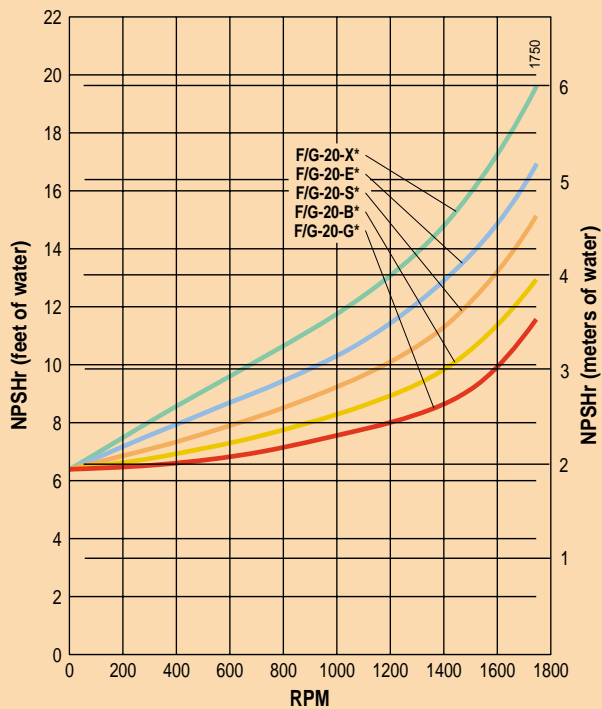

## Dry Lift

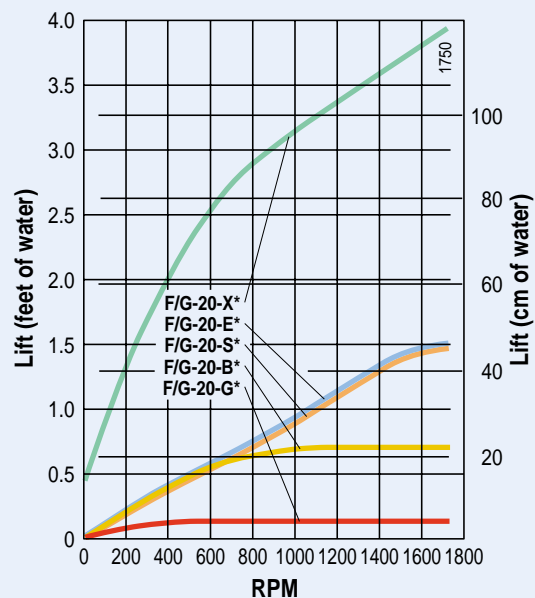

## \* Note

Performance and specification ratings apply to all configurations unless specifically noted otherwise.

Refer to installation guidelines and design considerations section for additional information.

# F/G-20 Series Dimensions

## F/G-20 Models with Metallic Pumping Head

Brass  
316 Stainless Steel  
Hastelloy® C

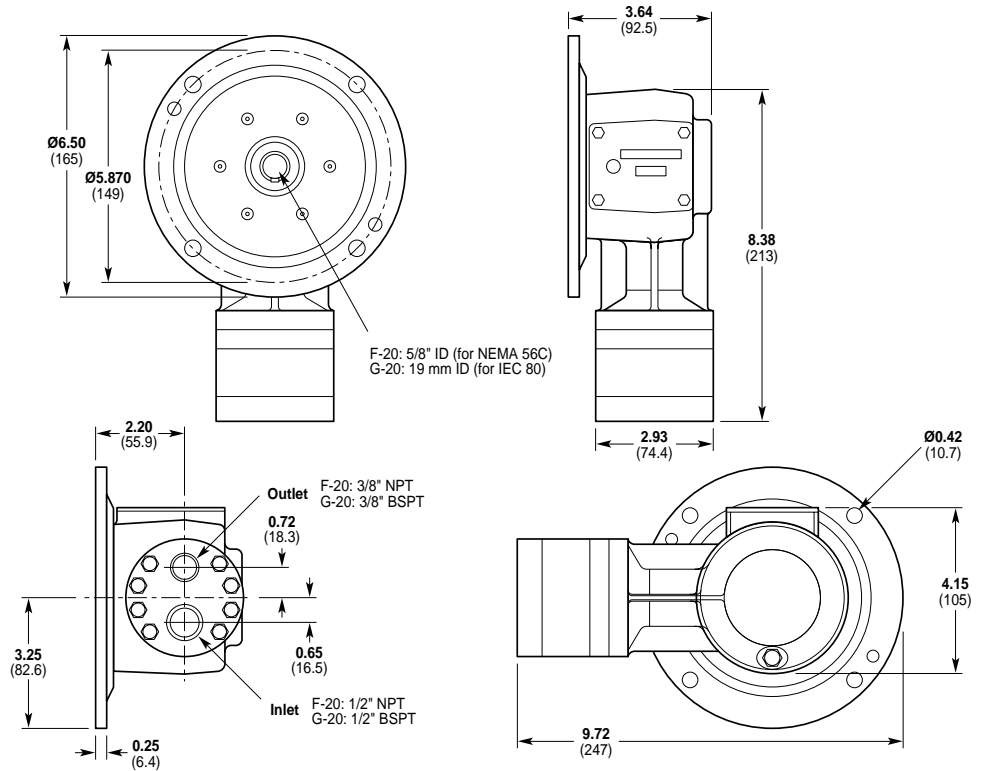

## F/G-20 Models with Non-metallic Pump Head

Kynar®  
Polypropylene

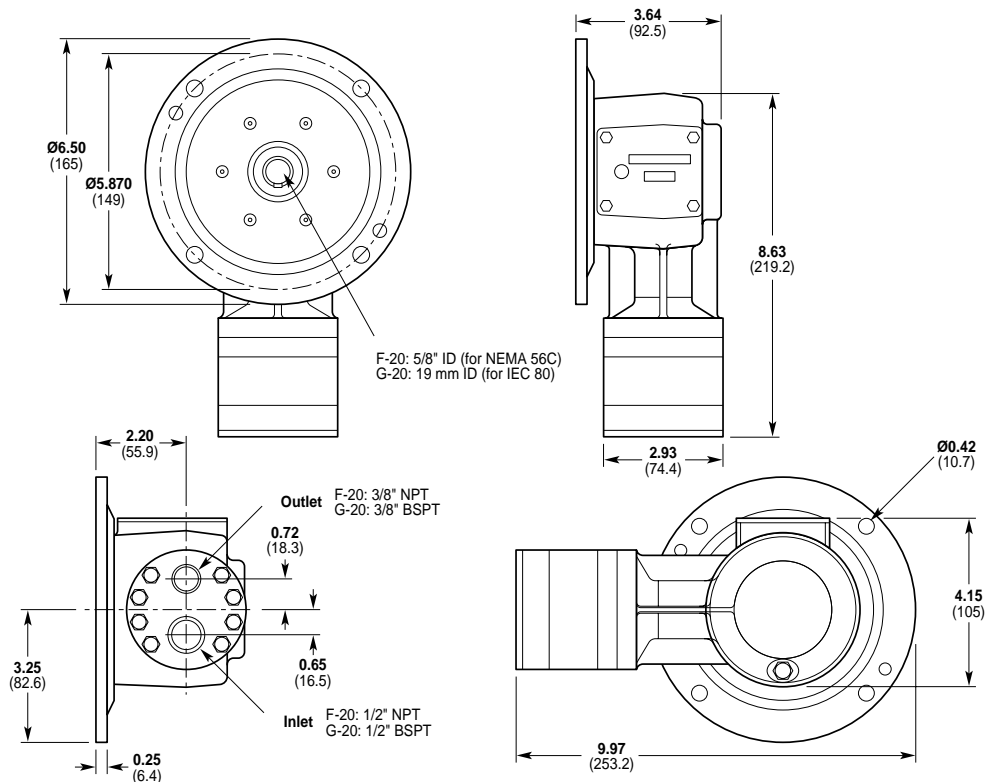

# F/G-20 Series Dimensions

## F/G-21 Models with Metallic Pumping Head

Brass  
316 Stainless Steel  
Hastelloy® C

— Note

*F/G-21 Pump/Motor Adapter flange ordered separately (see page 32)*

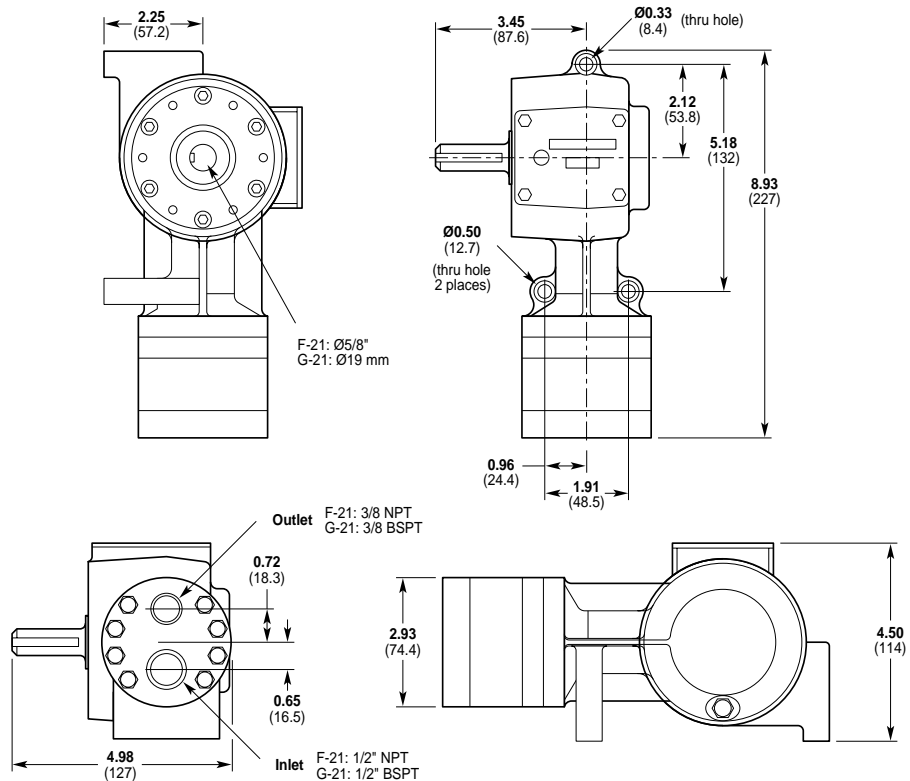

## F/G-21 Models with Non-metallic Pump Head

Kynar®  
Polypropylene

— Note

*F/G-21 Pump/Motor Adapter flange ordered separately (see page 32)*

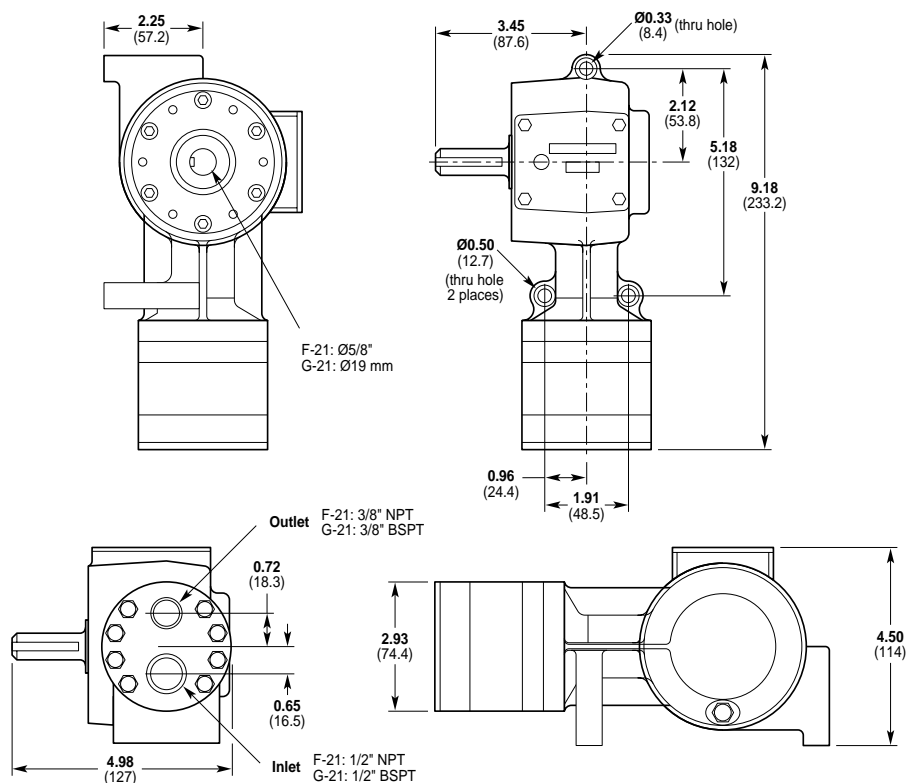

# F/G-20 Series Dimensions

## F/G-22 Models with Metallic Pumping Head

Brass  
316 Stainless Steel  
Hastelloy® C

— Note  
F/G-21 Pump/Motor Adapter  
flange ordered separately  
(see page 32)

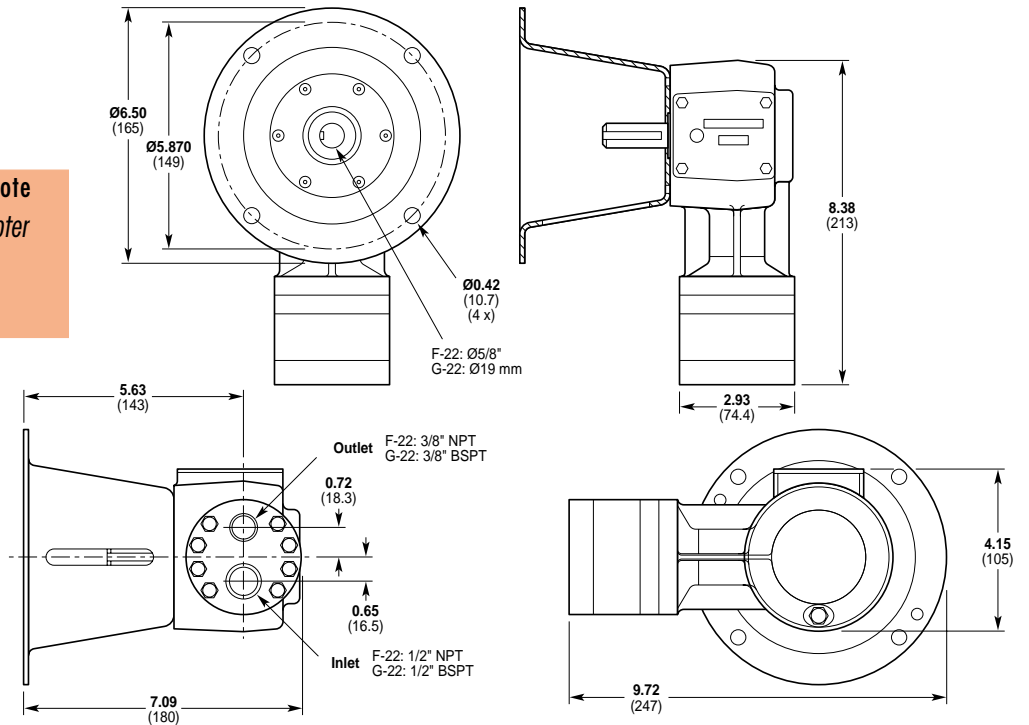

## F/G-22 Models with Non-metallic Pump Head

Kynar®  
Polypropylene

— Note  
F/G-21 Pump/Motor Adapter  
flange ordered separately  
(see page 32)

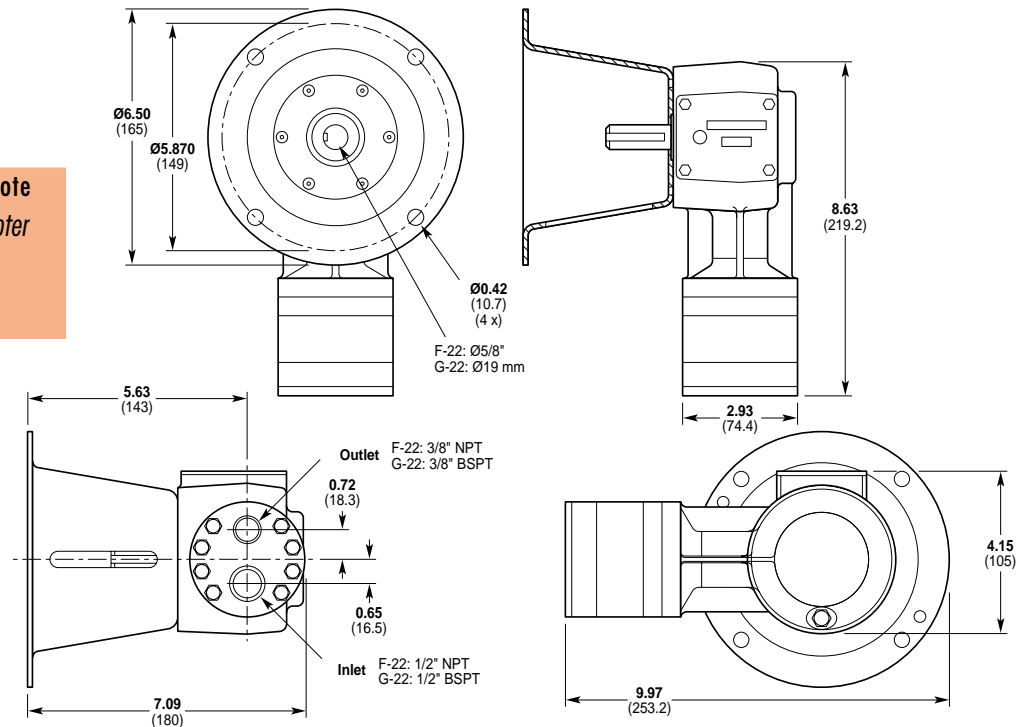

# F/G-20 Series Options

## Materials of Construction

Hydra-Cell pumps are manufactured in a variety of heavy-duty materials to meet specific pumping needs. Refer to the design section for more information on appropriate material selection and chemical compatibility. Other customized materials are available by special order. Contact factory application engineering department for further information.

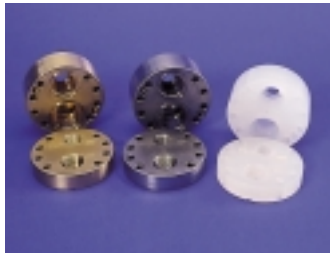

### Pumping Head

316 Stainless Steel  
Brass  
Kynar®  
Hastelloy® C  
Polypropylene

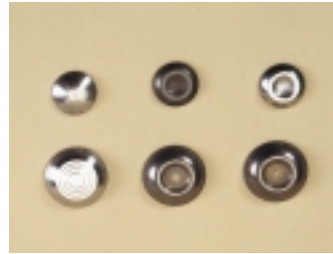

### Valves

17-7 PH Stainless Steel  
Ceramic  
Hastelloy® C  
Nitronic 50  
Tungsten Carbide



### Diaphragms & O-rings

Buna-N-XS  
EPDM  
Neoprene  
Teflon®  
Viton®-XT

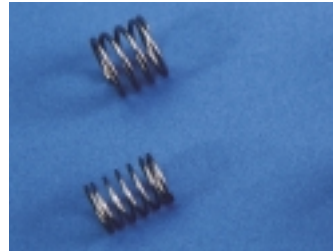

### Valve Springs

Elgiloy®  
Hastelloy® C



### Valve Seats

17-4 PH Stainless Steel  
316 Stainless Steel  
Ceramic  
Hastelloy® C  
Tungsten Carbide



### Valve Spring Retainers

Celcon®  
Kynar®  
Nylon  
Polypropylene  
17-7 PH Stainless Steel  
Hastelloy® C

# F/G-20 Series Accessories

## Options, Accessories and Custom Designs

See the Accessories Section for complete information on these other products:

- Valves
- Couplings
- Hose Connectors
- Hydra-Oil
- Oil Cooler and Filtering System
- Oil Reservoir
- Tool Kits
- Pump/Motor Adapters



## Pump/Motor Adapter

(Ordered separately)

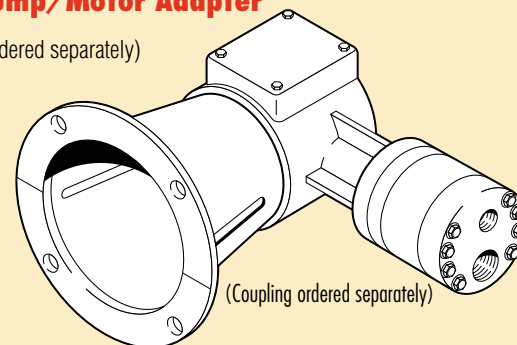

(Coupling ordered separately)

### Part Number: A04-005-1200

For F-21/22 for use with NEMA 56C, 143/145TC C-Face motors.

### Part Number: A04-006-1200

For G-21/22 for use with IEC 80-90 B5 Flange motors.

See the Accessories Section for dimensions.

# F/G-20 Series How To Order

## Ordering Information

A complete F/G-20 Series Model Number contains 12 digits including 9 customer-specified design options: for example F20XABGSNEPG

1	2	3	4	5	6	7	8	9	10	11	12
---	---	---	---	---	---	---	---	---	----	----	----

Digit	Order Code	Description
<b>1-3</b>	<b>Pump Configuration</b>	
	F20	Close-coupled to NEMA 56C (NPT ports)
	F21	Shaft-driven (NPT ports)
	F22	For use with pump/motor adapter (NPT ports)
	G20	Close-coupled to IEC 80 (BSPT ports)
	G22	For use with pump/motor adapter (BSPT ports)
<b>4</b>	<b>Hydraulic End Cam</b>	
	X	Max 0.96 gpm (3.79 lpm) @ 1750 rpm
	E	Max 0.73 gpm (2.76 lpm) @ 1750 rpm
	S	Max 0.55 gpm (2.08 lpm) @ 1750 rpm
	B*	Max 0.33 gpm (1.25 lpm) @ 1750 rpm
G*	Max 0.20 gpm (0.76 lpm) @ 1750 rpm	
<b>5</b>	<b>Pump Head Version</b>	
	A	Version A Pump Head (NPT ports)
D	Version D Pump Head (BSPT ports)	
<b>6</b>	<b>Pump Head Material</b>	
	B	Brass
	M	Kynar®
	P	Polypropylene
	S	316 Stainless Steel
	T	Hastelloy® C
<b>7</b>	<b>Diaphragm &amp; O-ring Material</b>	
	E	EPDM (requires EPDM-compatible oil – Digit 12 oil code J)
	G	Viton®-XT
	J*	Teflon® (available with X and E cams only; cannot be used with non-metallic heads)
	P	Neoprene
T	Buna-N-XS	
<b>8</b>	<b>Valve Seat Material</b>	
	C	Ceramic
	D	Tungsten Carbide
	H	17-4 PH Stainless Steel
	S	316 Stainless Steel
	T	Hastelloy® C

\* May require pressurized inlet.

Digit	Order Code	Description
<b>9</b>	<b>Valve Material</b>	
	C	Ceramic
	D	Tungsten Carbide
	F	17-4 PH Stainless Steel (machined)
	H	17-7 PH Stainless Steel
	N	Nitronic 50
T	Hastelloy® C	
<b>10</b>	<b>Valve Springs</b>	
	E	Elgiloy®
T	Hastelloy® C	
<b>11</b>	<b>Valve Spring Retainers</b>	
	C	Celcon
	H	17-7 PH Stainless Steel
	M	Kynar®
	P	Polypropylene
	T	Hastelloy® C
Y	Nylon	
<b>12</b>	<b>Hydra-Oil</b>	
	G	5W30 standard & cold-temp severe duty oil
	J	20-wt EPDM-compatible oil
K	20-wt food-contact oil	

### Replacement Hydraulic End Assembly

Complete F/G-20 Hydraulic End Assemblies are available as replacement items. The Hydraulic End contains all drive end components from the drive shaft up to and including the diaphragms. All Hydraulic Ends are factory tested and shipped with oil. To order a Replacement Hydraulic End, specify the desired Cam (Digit 4), the Diaphragm and O-ring Material (Digit 7), and the Hydra-Oil (Digit 12).

#### Part Number\*

F20	4*	XX	7*	XXXX	12*	G20	4*	XX	7*	XXXX	12*
F21	4*	XX	7*	XXXX	12*	G21	4*	XX	7*	XXXX	12*
F22	4*	XX	7*	XXXX	12*	G22	4*	XX	7*	XXXX	12*

\* Order Code Digits 4, 7 and 12 must be filled in when ordering.