

# SSC Series Engine Flush Kit (Safety Seacock Conversion) Installation, Operation, and Maintenance

**The Concept:** Converts most seacocks to Safety Seacocks, or adds an easy to access and use port into the engine cooling system for simplified winterization and maintenance.

SSC Series was introduced in response to customer comments about the virtues of GROCO's Safety Seacock series, and the desire to "convert" existing seacocks to Safety Seacock operation rather than having to replace an otherwise functional seacock that was already in place.

**Installation:** SSC series may be installed in any accessible location in the plumbing between the inlet seacock and the engine raw water pump. Most installations will be on top of an existing seacock or into the outlet side of a raw water strainer.

Greatest utility will be gained by installing SSC on top of a seacock because this is the lowest possible location in the bilge and will therefore allow bilge water level to be reduced to the lowest possible level.

SSC may be used with optional GROCO BSA Bilge Strainer and Adaptor Kit. Specify BSA-(SSC Pipe Size).

**Maintenance:** Remove the Quick Release Plug monthly and lubricate the O-Rings with TFE or Silicon Based grease. Do not use petroleum based lubricant.

**Operation:** To utilize SSC the seacock must first be closed. Grasp the pull-ring and turn 90-degrees counter-clockwise. Pull the Quick Release Plug straight out.

Insert the Service Adaptor (included) and lock with a 90-degree turn clockwise. The service adaptor has garden hose threads for connection to dockside water forcooling system flushing or for use with a GROCO vane pump to pimp antifreeze into the cooling system for winterization.

Refer to the drawings below for possible applications and uses.

## Safety Precautions:

- DO NOT remove the Quick Release Plug while the engine is running unless bilge water level is higher than the Quick Release Plug port.
- DO NOT remove the Quick Release Plug while the seacock is open. You will flood your bilge or you will sink your boat.
- While the Quick Release Plug is in place in the side of SSC, always "snap" the pull ring over the tab below the Quick Release Plug port.

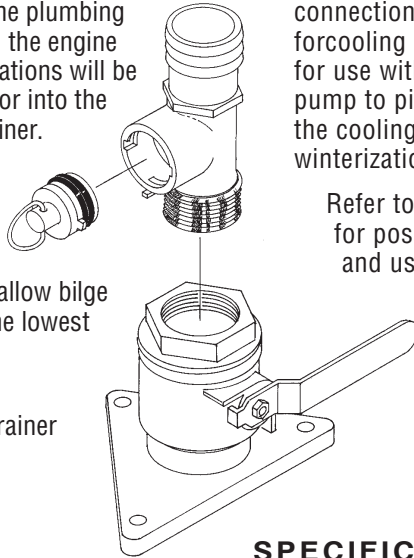
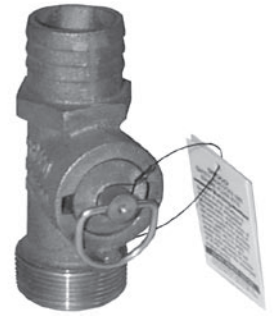

## SPECIFICATIONS

Model	Service Adaptor	Pipe Size	Hose ID	O-Rings
SSC-750	SBVSA-755	3/4" NPT	3/4"	2-111
SSC-1000	SBVSA-1005	1" NPT	1"	2-115
SSC-1250	SBVSA-1255	1-1/4" NPT	1-1/4"	2-118
SSC-1500	SBVSA-1505	1-1/2" NPT	1-1/2"	2-120
SSC-2000	SBVSA-2005	2" NPT	2"	2-128
SSC-2500	SBVSA-2505	2-1/2" NPT	2-1/2"	2-136
SSC-3000	SBVSA-3005	3" NPT	3"	2-144

## APPLICATIONS AND USES

### ENGINE COOLING SYSTEM FLUSHING

(Flushing with dockside water.)

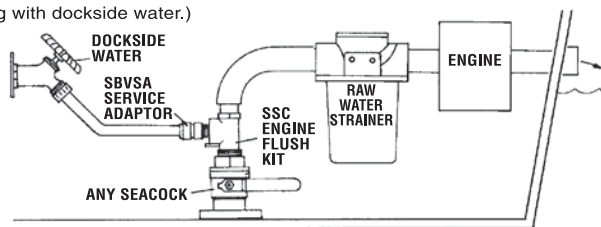

### ROUTINE BILGE PUMPING

(Engine evacuates remote bilge.)

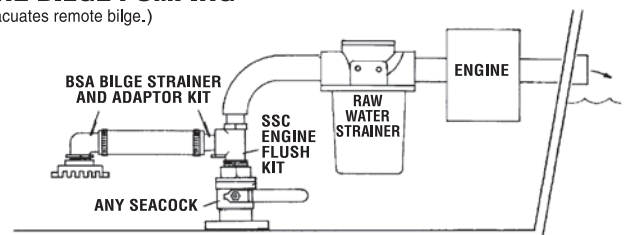

### WINTERIZING

(Pumping antifreeze into engine cooling system.)

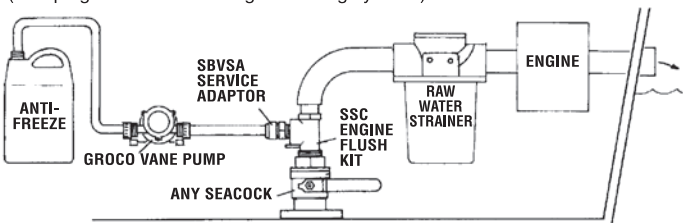

### EMERGENCY BILGE PUMPING

(Allows high bilge water to be drawn through open side port and pumped overboard through engine exhaust system.)

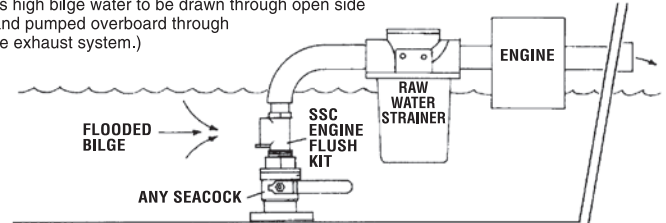

© 1999 GROCO MECHANICAL LABORATORIES, INC. ALL RIGHTS RESERVED.