

Models

Triplex Ceramic
Plunger Pump
Operating Instructions/
Repair and Service
Manual

P46W, P46W-HK & P46HT



Contents:

Installation Instructions:	page 2
Pump Specifications:	page 3-4
Kits/Torque Specs:	page 5
Pump Mounting Selection Guide:	page 5
Exploded View:	page 6
Parts List:	page 7
Trouble Shooting:	page 8
Recommended Spare Parts List:	page 8
Repair Instructions:	page 9-11
Dimensions:	back page
Warranty Information:	back page

Updated 9/09

INSTALLATION INSTRUCTIONS - P46W, P46W-HK, & P46HT

Installation of the Giant Industries, Inc., pump is not a complicated procedure, but there are some basic steps common to all pumps. The following information is to be considered as a general outline for installation. If you have unique requirements, please contact Giant Industries, Inc. or your local distributor for assistance.

1. The pump should be installed flat on a base to a maximum of a 15 degree angle of inclination to ensure optimum lubrication.
2. The inlet to the pump should be sized for the flow rate of the pump with no unnecessary restrictions that can cause cavitation. Teflon tape should be used to seal all joints. If pumps are to be operated at temperatures in excess of 160°F (P46W), 195°F (P46W-HK), or 220°F (P46HT) it is important to insure a positive head to the pump to prevent cavitation. See NPSHR curve for P46HT on page 4.
3. The discharge plumbing from the pump should be properly sized to the flow rate to prevent line pressure loss to the work area. It is essential to provide a safety bypass valve between the pump and the work area to protect the pump from pressure spikes in the event of a blockage or the use of a shut-off gun.

4. Use of a dampener is necessary to minimize pulsation at drive elements, plumbing, connections, and other system areas. The use of a dampener with Giant Industries, Inc. pumps is optional, although recommended by Giant Industries, Inc. to further reduce system pulsation. Dampeners can also reduce the severity of pressure spikes that occur in systems using a shut-off gun. A dampener must be positioned downstream from the unloader.

5. Crankshaft rotation on Giant Industries, Inc. pumps should be made in the direction designated by the arrows on the pump crankcase. Reverse rotation may be safely achieved by following a few guidelines available upon request from Giant Industries, Inc. Required horsepower for system operation can be obtained from the charts on pages 3-4. The open end shaft must be covered by the shaft protector (17).

6. Before beginning operation of your pumping system, remember: Check that the crankcase and seal areas have been properly lubricated per recommended schedules. Do not run the pump dry for extended periods of time. Cavitation will result in severe damage. Always remember to check that all plumbing valves are open and that pumped media can flow freely to the inlet of the pump.

Finally, remember that high pressure operation in a pump system has many advantages. But, if it is used carelessly and without regard to its potential hazard, it can cause serious injury.

IMPORTANT OPERATING CONDITIONS

Failure to comply with any of these conditions invalidates the warranty.

1. Prior to initial operation, add oil to the crankcase so that oil level is between the two lines on the oil dipstick. DO NOT OVERFILL.

Use Giant Oil # 01154 or the equivalent SAE 80W - 90 Industrial Gear Oil

Crankcase oil should be changed after the first 50 hours of operation, then at regular intervals of 500 hours or less depending on operating conditions.

2. Pump operation must not exceed rated pressure, volume, or RPM. A pressure relief device must be installed in the discharge of the system.

3. Acids, alkalines, or abrasive fluids cannot be pumped unless approval in writing is obtained before operation from Giant Industries, Inc.

4. Run the pump dry approximately 10 seconds to drain the water before exposure to freezing temperatures.

Specifications

Model P46W/P46W-HK

	<u>U.S.</u>	<u>Metric</u>
Volume	Up to 3.9 GPM	14.7 L/M
Discharge Pressure	2200 PSI	150 bar
Inlet Pressure	-4.35 to 145 psi	-0.3 to 10 bar
Maximum Crankshaft Rotation Speed		Up to 1420 RPM
Stroke	0.56"	14.1mm
Crankcase Oil Capacity	8 fl.oz.	0.24 Liters
Temperature of Pumped Fluids	Up to 160°F	71°C (P46W)
.....	Up to 195°F	90°C (P46-HK)
Plunger Diameter	0.71"	18mm
Inlet Ports		(2) 1/2" BSP
Discharge Ports		(2) 3/8" BSP
Pulley Mounting		Either Side
Shaft Rotation		Top of pulley towards head
Weight	13.9 lbs	6.3 kg
Crankshaft Diameter	0.71"	18mm
Volumetric Efficiency @ 1420RPM		0.96
Mechanical Efficiency @ 1420RPM		0.80

Consult the factory for special requirements that must be met if the pump is to operate beyond one or more of the limits specified above.

PULLEY INFORMATION

Pulley selection and pump speed are based on a 1725 RPM motor and "B" section belts. When selecting desired GPM, allow for a ±5% tolerance on pumps output due to variations in pulleys, belts and motors among manufacturers.

1. Select GPM required, then select appropriate motor and pump pulley from the same line.
2. The desired pressure is achieved by selecting the correct nozzle size that corresponds with the pump GPM.

HORSEPOWER INFORMATION

The ratings shown in the chart reflect the horsepower requirements for electric motors. We recommend motors with a 1.15 service factor be specified.

To compute specific pump horsepower requirements, use the following formula:

$$(GPM \times PSI) / 1450 = HP$$

P46W / P46W-HK PULLEY SELECTION & HORSEPOWER REQUIREMENTS - ELECTRIC MOTOR							
PUMP PULLEY	MOTOR PULLEY	RPM	GPM	1000 PSI	1500 PSI	1700 PSI	2200 PSI
7.75"	3.55"	745	2.0	1.4	2.1	2.3	3.0
7.75"	4.25"	910	2.5	1.7	2.6	2.9	3.8
7.75"	5.25"	1140	3.1	2.1	3.2	3.6	4.7
7.75"	5.95"	1305	3.6	2.5	3.7	4.2	5.4
7.75"	6.45"	1420	3.9	2.7	4.0	4.5	5.9

Specifications Model P46HT

	U.S.	Metric
Volume.....	147.3 GPH (2.5 GPM)	557.5 L/H (9.3 L/M)
Discharge Pressure.....	900 PSI	60 bar
Inlet Pressure	See NPSHR curve below	
Maximum Crankshaft Rotation Speed	900 RPM	
Stroke.....	.056"	14.1mm
Plunger Diameter071"	18mm
Crankcase Capacity	8 fl. oz.	0.24 Liters
Temperature	Up to 221°F	105° C
Inlet Ports	(2) 1/2" BSP	
Discharge Ports	(2) 3/8" BSP	
Pulley Mounting	Either Side	
Shaft Rotation	Top of pulley towards head	
Weight	13.9 lbs.	6.3kg
Crankshaft Diameter71"	18mm

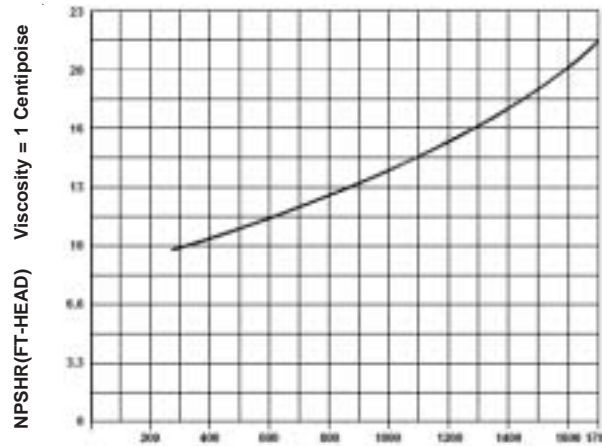

Consult the factory for special requirements that must be met if the pump is to operate beyond one or more of the limits specified above.

PULLEY INFORMATION

Pulley selection and pump speed are based on a 1725 RPM motor and "B" section belts. When selecting desired GPM, allow for a ±5% tolerance on pumps output due to variations in pulleys, belts and motors among manufacturers.

1. Select GPM required, then select appropriate motor and pump pulley from the same line.
2. The desired pressure is achieved by selecting the correct nozzle size that corresponds with the pump GPM.

HORSEPOWER INFORMATION

The ratings shown in the chart reflect the horsepower requirements for electric motors. We recommend motors with a 1.15 service factor be specified.

To compute specific pump horsepower requirements, use the following formula:

$$(GPM \times PSI) / 1450 = HP$$

P46HT PULLEY SELECTION & HORSEPOWER REQUIREMENTS - ELECTRIC MOTOR								
PUMP PULLEY	MOTOR PULLEY	RPM	GPM	GPH	200 PSI	400 PSI	600 PSI	900 PSI
7.75"	2.0"	385	1.05	62.9	0.14	0.29	0.43	0.65
7.75"	3.25"	676	1.8	110.6	0.25	0.50	0.74	1.12
7.75"	4.25"	900	2.5	147.3	0.34	0.69	1.03	1.55

P46W, P46W-HK & P46HT REPAIR KITS

Plunger Packing Kit, P46W #09038

Item	Part #	Description	Qty.
31	07241	V-Sleeve	3
40	07234	O-Ring	3

Complete Plunger Packing Kit, P46W #09081

Item	Part #	Description	Qty.
31	07241	V-Sleeve	3
40	07234	O-Ring	3
50	07239	Rear V-Sleeve	3
51	07240	Support Ring	3

Plunger Packing Kit, P46W-HK, P46HT #09514

Item	Part #	Description	Qty.
31	11511	Sleeve	3
40	07234	O-Ring, Adapter	3
50	11512	High Temp. Rear Seal	6
51	07240	Support Ring	3

Ceramic Plunger Assembly Kit #09539

Item	Part #	Description	Qty.
24A	07021	Ceramic Plunger	3
24B	08456	Tension Screw	3
24C	07676	Copper Ring	3
25	06648/13333*	Flinger	3

* p/n 13333 is needed for older P46W pumps with brass retainers (p/n 08064).

Valve Assembly Kit P46W & P46W-HK #09039

(One Kit Each for Inlet or Discharge Valves)

Item	Part #	Description	Qty.
34	07325	Spring Retainer	3
35	06017-0100	Valve Spring	3
36	06016	Valve Plate	3
37	06014	Valve Seat	3
38	06015	O-Ring, Valve Seat	3
40	07234	O-Ring, Adapter	3
42	12004	O-Ring, Inlet Plug	3
44	07035	O-Ring, Discharge Plug	3

Valve Assembly Kit, P46HT #09497

(One Kit Each for Inlet or Discharge Valves)

Item	Part #	Description	Qty.
34	05593	Spring Retainer	3
35	06017-0100	Valve Spring	3
36	06016	Valve Plate	3
37	06014	Valve Seat	3
38	06015	O-Ring	3
40	07234	O-Ring, Adaptor	3
42	12004	O-Ring, Inlet Plug	3
44	07035	O-Ring, Discharge Plug	3

P46W, P46W-HK & P46HT TORQUE SPECIFICATIONS

Position	Item#	Description	Torque Amount
24B	08456	Tension Screw, Plunger	105 in.-lbs.
41	07235	Plug, Manifold (Inlet)	52 ft.-lbs.
43	07034	Plug, Manifold (Outlet)	52 ft.-lbs.
46	08040	Hex Nut, Manifold Stud	35 ft.-lbs.

Pump Mounting Selection Guide

<p>Bushings 01065 - 18 mm Tapered H Bushing</p>	<p>Rails 01034 - Steel Box Rails (L=9.25" x W=1.18" x H=1.62") 01075 - Plated Steel Channel Rails (L=9.00" x W=2.12" x H=2.50")</p>
<p>Pulley & Sheaves 01061 - 7.75" Cast Iron 1 gr. - AB Section 01062 - 7.75" Cast Iron - 2 gr. - AB Section 01066 - 18 mm - 8" Steel Pulley - 1 gr.</p>	

P46W, P46W-HK & P46HT PARTS LIST

<u>ITEM</u>	<u>PART</u>	<u>DESCRIPTION</u>	<u>QTY.</u>	<u>ITEM</u>	<u>PART</u>	<u>DESCRIPTION</u>	<u>QTY.</u>
1	07222	Crankcase	1	31	07241	V-Sleeve (P46W only)	3
2	07181	Vent/Filler Plug with Seal	1	31	11511	V-Sleeve, High Temp. (P46W-HK, P46HT)	3
3	08004	Cover, Crankcase	1				
4	08005	O-Ring	1	32	07231	Support Ring	3
5	08008	Oil Dipstick	1	33	07232	Pressure Spring	3
6	01009	O-Ring	1	34	07325	Retainer, Spring (P46W, P46W-HK)	6
9	07188	Cylinder Screw with Slot	4				
10	07223-0100	Spring Washer	4	34	05593	Retainer, Spring (P46HT)	6
11	08012	Oil Drain Plug with Seal	1	35	06017-0100	Valve Spring	6
11A	06709	Gasket, Oil Drain Plug	1	36	06016	Valve Plate	6
12	07224	Bearing Cover	2	37	06014	Valve Seat	6
14	08015	Radial Shaft Seal	2	38	06015	O-Ring	6
15	08020	Ball Bearing	2	39	07233	Suction Valve Adaptor	3
16	07225	Screw and Washer	6	40	07234	O-Ring, Adapter	3
17	07226	Shaft Protector	1	41	07235	Plug, Manifold (Inlet)	3
18	07227	Crankshaft	1	42	12004	O-Ring, for Item 41	3
19	01024	Key	1	43	07792	Plug, Manifold (Discharge)	3
20	08024	Connecting Rod	3	44	07035	O-Ring for Item 43	3
22	07201	Crosshead Assy.	3	45	07215	Stud, Manifold	2
23	01031	Crosshead Pin	3	46	08040	Hex Nut, Manifold Stud	2
24A	07021	Plunger Pipe	3	47	08041	Spring Washer, Stud	2
24B	08456	Tension Screw	3	48	07237	Housing, Rear V-Sleeve	1
24C	07676	Copper Ring	3	49	07238	O-Ring, Rear V-Sleeve Housing	1
25*	06648	Flinger	3				
26	07206	Radial Shaft Seal	3	50	07239	Rear V-Sleeve (P46W only)	3
26A	11510	Spacer Sleeve	3	50	11512	High Temperature Seal (P46W-HK & P46HT)	6
28	07207	Shim, Manifold Stud	2				
29	07033	Manifold	1	51	07240	Support Ring, Rear V-Sleeve	3
29A	06176	Stud Bolt (P46HT only)	2	52	07109	Plug, 1/2" BSP	1
30	07230	Pressure Ring	3	53	13338	Plug, 3/8" BSP	1

* This will not fit into older P46W pumps with brass retainers (#08064). It can only be used with part number 11510 (#26A). You can substitute p/n 13333 for 06648 only if the brass retainer (#08064) is used.

PUMP SYSTEM MALFUNCTION

<u>MALFUNCTION</u>	<u>CAUSE</u>	<u>REMEDY</u>
The Pressure and/or the Delivery Drops	Worn packing seals Broken valve spring Belt slippage Worn or Damaged nozzle Fouled discharge valve Fouled inlet strainer Worn or Damaged hose Worn or Plugged relief valve on pump Cavitation pump for restrictions Unloader	Replace packing seals Replace spring Tighten or Replace belt Replace nozzle Clean valve assembly Clean strainer Repair/Replace hose Clean, Reset, and Replace worn parts Check suction lines on inlet of Check for proper operation
Water in crankcase	High humidity Worn seals	Reduce oil change interval Replace seals
Noisy Operation	Worn bearings Cavitation	Replace bearings, Refill crankcase oil with recommended lubricant Check inlet lines for restrictions and/or proper sizing
Rough/Pulsating Operation with Pressure Drop	Worn packing Inlet restriction Accumulator pressure Unloader Cavitation	Replace packing Check system for stoppage, air leaks, correctly sized inlet plumbing to pump Recharge/Replace accumulator Check for proper operation Check inlet lines for restrictions and/or proper size
Pump Pressure as Rated, Pressure Drop at gun	Restricted discharge plumbing	Re-size discharge plumbing to flow rate of pump
Excessive Leakage	Worn plungers Worn packing/seals Excessive vacuum Cracked plungers Inlet pressure too high	Replace plungers Adjust or Replace packing seals Reduce suction vacuum Replace plungers Reduce inlet pressure
High Crankcase Temperature	Wrong Grade of oil Improper amount of oil in crankcase	Giant oil is recommended Adjust oil level to proper amount

Preventative Maintenance Check-List & Recommended Spare Parts List						
Check	Daily	Weekly	50hrs	Every 500 hrs	Every 1500 hrs	Every 3000 hrs
Oil Level/Quality	X					
Oil Leaks	X					
Water Leaks	X					
Belts, Pulley		X				
Plumbing		X				
Recommended Spare Parts						
Oil Change (8 oz.) p/n 1154			X	X		
Plunger Packing Kits (1 kit/pump) (See page 5 for kit list)					X	
Valve Assembly Kit (1 kit/pump) (See page 5 for kit list)					X	
Oil Seal Kit (1 kit/pump) (See page 5 for kit list)						X

REPAIR INSTRUCTIONS - P46W, P46W-HK, P46HT

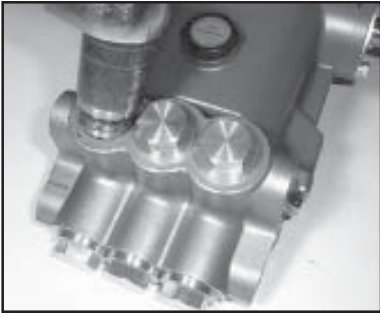

1. With a 22mm socket, remove the three discharge (43) and three inlet (41) manifold plugs. Check o-rings (42 & 44) for wear and replace as necessary.

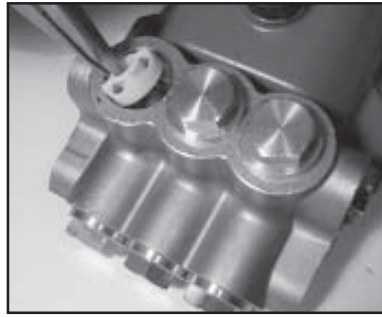

2. Remove the discharge spring retainer (34), valve spring (35), and valve plate (36).

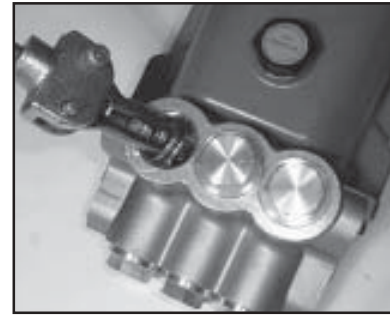

3. Use a small slide hammer to remove valve seats (37) from manifold (29). Inspect valve plates (36) and valve seats (37) for wear. If excessive pitting is seen, replace the worn parts. Check valve seat o-ring (38) for wear and replace as necessary.

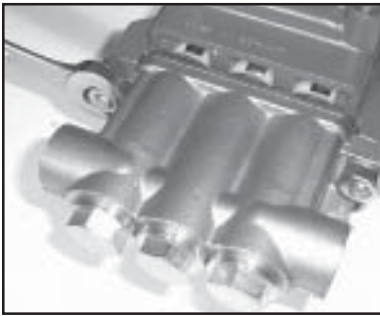

4. Drain the oil from the pump. Turn the pump over to remove the two manifold stud nuts (46) with a 17mm wrench.

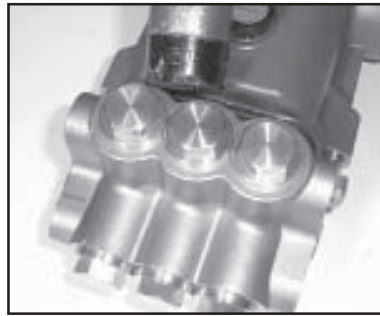

5. Tap the back of the manifold (29) with a rubber mallet to dislodge, and slide off the pump.

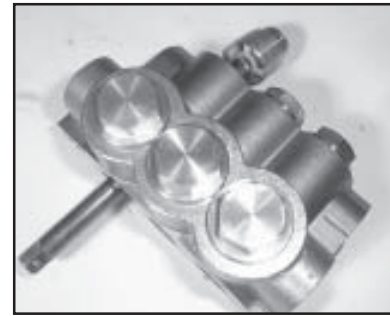

6. From the front inlet valve ports, remove the inlet valve assembly (34-40).

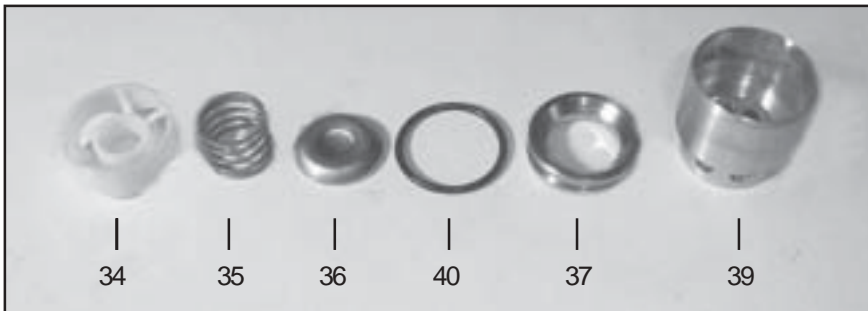

7. Inspect and clean the valve assembly parts. If pitted or worn, replace inlet valve seats (37), valve plates (36), spring (35) and spring retainers (34). Reinsert items 34-38 into valve adapter (39).

NOTE: Contact Giant Industries for Service School Information. Phone: (419)-531-4600

REPAIR INSTRUCTIONS - P46W, P46W-HK, & P46HT

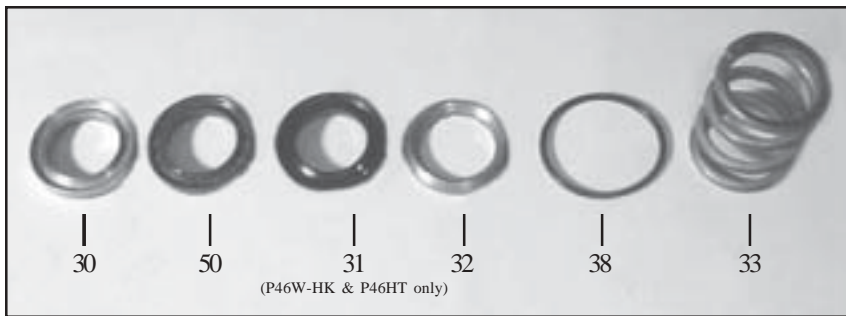

8. The pressure rings (item 30) can now be removed by pulling straight out. Inspect and clean manifold (29) and pressure ring. Replace if necessary. From the front of the pump reinstall pressure rings into manifold (29) with grooved side towards front of manifold. Install new v-sleeves (31), with grooved sides towards front of pump. For P46W-HK & P46HT pumps, install high temperature seal (50) before v-sleeve (31) with grooved sides towards front of pump. Replace the support rings (32) and pressure springs (33) into manifold (29). Install valve assembly (34-40) into manifold (29). Reinstall manifold plugs (43) and torque plugs to 52 ft.-lbs.

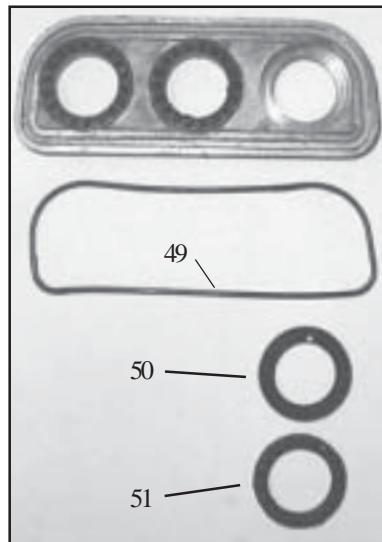

9. The rear V-sleeve housing (48) may be removed by prying evenly outward with a flat screwdriver. After slipping housing over plunger, inspect rear v-sleeves (50), support rings (51) and O-ring (49) and replace as necessary.

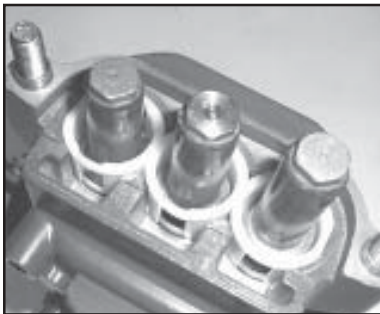

10. Inspect ceramic plunger (24A) tips for wear. If necessary, replacement of the ceramic plungers may be accomplished by removing the plunger bolt assemblies (24B and 24C) with a 13mm wrench. Ceramic plungers should now slide off the stainless steel plunger base (22). Excessive resistance to plunger removal may be overcome by heating the stainless steel plunger base. This will melt any excess loc-tite beneath the ceramic plunger allowing easy removal.

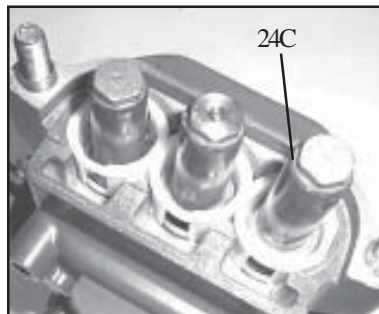

11. Replace copper ring (24C) onto plunger bolt (24B). Slide plunger bolt assembly into ceramic plunger (24A). Apply a light film of loc-tite to plunger bolt threads and place plunger assembly onto stainless steel plunger base (22) and tighten to 105 in.-lbs.
12. To replace plunger oil seals (26), proceed to "Gear End Disassembly" section below. Otherwise, continue as described below.



13. Before replacing pump manifold (29), first rotate crankshaft (18) until two outside plungers (24A) extend evenly forward. Next lubricate rear v-sleeves (50) and support ring (51) in the rear v-sleeve housing (48) and slide housing over plungers. Lubricate ceramic plungers with a light film of oil. Carefully and evenly slide manifold over plungers and press manifold firmly against crankcase (1). Replace manifold stud bolts (45), washers (47) and nut (46) and tighten to 35 ft.-lbs.

NOTE: Contact Giant Industries for Service School Information. Phone: (419)-531-4600

REPAIR INSTRUCTIONS - P46W, P46W-HK, & P46HT

Gear End Disassembly

14. Remove the crankcase cover bolts (9). Inspect the crankcase cover O-ring (4) for wear. Replace if necessary.
15. Inspect the dip stick (5) vent hole for signs of clogging. Clean if necessary.
16. To remove the crankshaft (18), first remove the bearing cover plates (12) Remove the key (19).
17. Hold the pump rear assembly with a wooden fixture, or other suitable device, in order to secure it while removing the crankshaft (18). Using a plastic mallet, tap the crankshaft (18) from one side while turning it from the other side. The turning insures that during this sequence the crankshaft does not become wedged against the connecting rods (20). The far side bearing (15) will remain in the crankcase (1). When free, the crankshaft (18) can be removed by hand.
18. The crankshaft bearing (15) remains on the crankshaft (18) as it is removed. The near side crankshaft seal (14) will be removed by this procedure.
19. If necessary, use a bearing puller to remove crankshaft bearing (15).
20. Remove the connecting rod (20) and plunger rod/crosshead assembly (22) from the rear of the pump by pulling straight out of the crosshead guides.
21. To remove the crankcase oil seal (26), tap oil seal out from the rear of the crankcase using a dowel and rubber mallet. The area onto which the oil seal rests should be clean and dry. Put a small drop of loc-tite on the oil seals and place into crankcase with clips facing the rear of the pump.
22. To remove the crosshead pin (23) from the crosshead (22), the assembly should be positioned on a wooden fixture to avoid damage to crosshead. Drive out pin (23) on opposite side of mark on the crosshead. On those pumps without mark on crosshead, drive out pin by tapping on tapered side of pin.
23. To remove the bearing remaining in the crankcase, insert small end of Giant Bearing tool and tap with a rubber mallet untill bearing and seal are completely removed. The bearing can only be removed from the inside by inserting the Giant Bearing Tool through the opposite side of the crankcase (1) and should be inspected for possible damage.

Gear End Reassembly

24. To reassemble, place the far bearing in the crankcase bearing housing and with the Giant Bearing tool as a driver, tap into the crankcase (1) using a rubber mallet.
25. Insert the far side crankshaft oil seal (14) with the Giant Bearing Tool making sure it is firmly seated and well oiled. Always make sure that the crankshaft seal (14) lip does not show signs of wear. Replace the bearing cover (12) and tighten securely.
26. Replace the connecting rod (20) and plunger rod/crosshead assembly (22) by press-fitting the crosshead pin (23). Make sure to insert the beveled edge of the crosshead pin into crosshead. If the crosshead has a mark, install pin from marked side. The crosshead pin (23) should not extend beyond either side of the crosshead in order to prevent damage to the crosshead bore of the crankcase.
27. Place each crosshead/plunger assembly (22) into the pump making sure that all of the parts are well oiled before insertion into the crankcase.
28. Replace near side bearing on crankshaft (18) and use mallet to tap into place.
29. Take the crankshaft (18) end with the bearing and insert the other end through the bearing housing carefully threading the lobes of the crankshaft through the well lubricated connecting rods (20). Turning the crankshaft while tapping it through the connecting rods will help prevent binding and possible damage to the connecting rods. Continue tapping the crankshaft through the connecting rods (20) until it is firmly seated into far side bearing.
30. Insert the near side crankshaft oil seal (14), making sure it is firmly seated and well oiled. Replace the bearing cover (12) and tighten securely.
31. See instructions (13 above) for re-installing fluid end onto gear end.

P46W, P46W-HK & P46HT DIMENSIONS - Inches

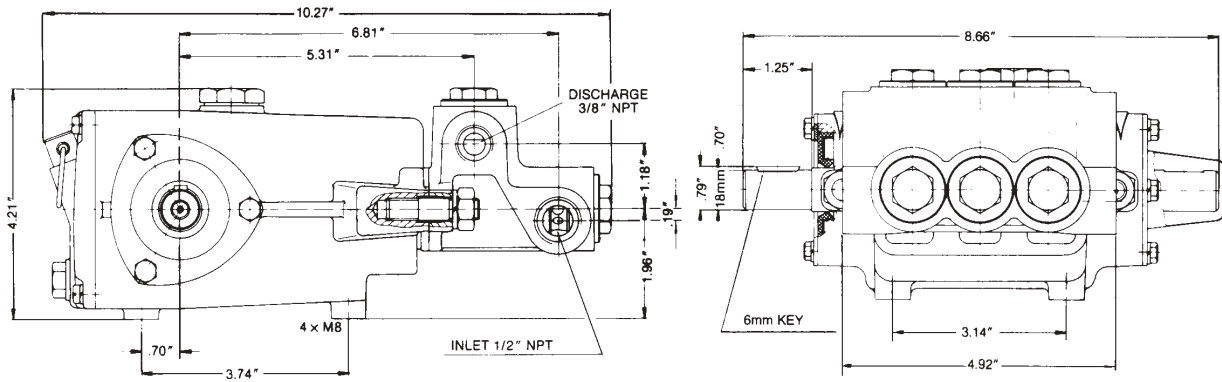

GIANT INDUSTRIES LIMITED WARRANTY

Giant Industries, Inc. pumps and accessories are warranted by the manufacturer to be free from defects in workmanship and material as follows:

1. For portable pressure washers and car wash applications, the discharge manifolds will never fail, period. If they ever fail, we will replace them free of charge. Our other pump parts, used in portable pressure washers and in car wash applications, are warranted for five years from the date of shipment for all pumps used in NON-SALINE, clean water applications.
2. One (1) year from the date of shipment for all other Giant industrial and consumer pumps.
3. Six (6) months from the date of shipment for all rebuilt pumps.
4. Ninety (90) days from the date of shipment for all Giant accessories.

This warranty is limited to repair or replacement of pumps and accessories of which the manufacturer's evaluation shows were defective at the time of shipment by the manufacturer. The following items are NOT covered or will void the warranty:

1. Defects caused by negligence or fault of the buyer or third party.
2. Normal wear and tear to standard wear parts.
3. Use of repair parts other than those manufactured or authorized by Giant.
4. Improper use of the product as a component part.
5. Changes or modifications made by the customer or third party.
6. The operation of pumps and or accessories exceeding the specifications set forth in the Operations Manuals provided by Giant Industries, Inc.

Liability under this warranty is on all non-wear parts and limited to the replacement or repair of those products returned freight prepaid to Giant Industries which are deemed to be defective due to workmanship or failure of material. A Returned Goods Authorization (R.G.A.) number and completed warranty evaluation form is required prior to the return to Giant Industries of all products under warranty consideration. Call (419)-531-4600 or fax (419)-531-6836 to obtain an R.G.A. number.

Repair or replacement of defective products as provided is the sole and exclusive remedy provided hereunder and the MANUFACTURER SHALL NOT BE LIABLE FOR FURTHER LOSS, DAMAGES, OR EXPENSES, INCLUDING INCIDENTAL AND CONSEQUENTIAL DAMAGES DIRECTLY OR INDIRECTLY ARISING FROM THE SALE OR USE OF THIS PRODUCT.

THE LIMITED WARRANTY SET FORTH HEREIN IS IN LIEU OF ALL OTHER WARRANTIES OR REPRESENTATION, EXPRESS OR IMPLIED, INCLUDING WITHOUT LIMITATION ANY WARRANTIES OR MERCHANTABILITY OR FITNESS FOR A PARTICULAR PURPOSE AND ALL SUCH WARRANTIES ARE HEREBY DISCLAIMED AND EXCLUDED BY THE MANUFACTURER.



Giant Industries, Inc.
900 N. Westwood Ave.
Toledo, OH 43607
419-531-4600
419-531-6836 Fax
www.giantpumps.com