

P300 Series - 12 & 20 mm versions

Triplex Ceramic
Plunger Pump
Operating Instructions/
Repair and Service Manual

For Models: P314, P318, P321, P324, P327



GIANT
Performance Under Pressure

Contents:

Installation Instructions:	page 2
Pump Specifications:	page 3
Exploded View:	page 4
Parts List:	page 5
Kits/Torque Specifications:	page 6
Pump Mounting Selection Guide:	page 6
Trouble Shooting:	page 7
Recommended Spare Parts List:	page 7
Repair Instructions:	pages 8-10
Dimensions:	page 11
Warranty Info:	back page

Updated 06/13

INSTALLATION INSTRUCTIONS

Installation of the Giant Industries, Inc., pump is not a complicated procedure, but there are some basic steps common to all pumps. The following information is to be considered as a general outline for installation. If you have unique requirements, please contact Giant Industries, Inc. or your local distributor for assistance.

1. The pump should be installed flat on a base to a maximum of a 15 degree angle of inclination to ensure optimum lubrication.
2. The inlet to the pump should be sized for the flow rate of the pump with no unnecessary restrictions that can cause cavitation. Teflon tape should be used to seal all joints. If pumps are to be operated at temperatures in excess of 160° F, it is important to insure a positive head to the pump to prevent cavitation.
3. The discharge plumbing from the pump should be properly sized to the flow rate to prevent line pressure loss to the work area. It is essential to provide a safety bypass valve between the pump and the work area to protect the pump from pressure spikes in the event of a blockage or the use of a shut-off gun.
4. Use of a dampener is necessary to minimize pulsation at drive elements, plumbing, connections, and other system areas. The use of a dampener with

Giant Industries, Inc. pumps is optional, although recommended by Giant Industries, Inc. to further reduce system pulsation. Dampeners can also reduce the severity of pressure spikes that occur in systems using a shut-off gun. A dampener must be positioned downstream from the unloader.

5. When viewed from the side of the pump, crankshaft rotation is clockwise on pumps with left handed shafts and counterclockwise on pumps with right handed shafts. Reverse rotation may be safely achieved by removing the valve casing from the crankcase and rotate the pumps 180 degrees to the desired position. Be certain to rotate the seal case (item #20) as well, so that the weep holes are down at the six o'clock position. Exchange the oil fill and the oil drain plugs, also. Refer to the repair instructions as necessary for the proper assembly sequence. Required horsepower for system operation can be obtained from the date located on page 3.
6. Before beginning operation of your pumping system, remember: Check that the crankcase and seal areas have been properly lubricated per recommended schedules. Do not run the pump dry for extended periods of time. Cavitation will result in severe damage. Always remember to check that all plumbing valves are open and that pumped media can flow freely to the inlet of the pump.

Finally, remember that high pressure operation in a pump system has many advantages. But, if it is used carelessly and without regard to its potential hazard, it can cause serious injury.

IMPORTANT OPERATING CONDITIONS

Failure to comply with any of these conditions invalidates the warranty.

1. Prior to initial operation, add oil to the crankcase so that oil level is between the two lines on the oil dipstick. **DO NOT OVERFILL.**

Use Giant oil - P/N 01153 (20W-50 non-detergent motor oil)

Crankcase oil should be changed after the first 50 hours of operation, then at regular intervals of 500 hours or less depending on operating conditions.

2. Pump operation must not exceed rated pressure, volume, or RPM. A pressure relief device must be installed in the discharge of the system.
3. Acids, alkalines, or abrasive fluids cannot be pumped unless approval in writing is obtained before operation from Giant Industries, Inc.
4. Run the pump dry approximately 10 seconds to drain the water before exposure to freezing temperatures.

Consult the factory for special requirements that must be met if the pump is to operate beyond one or more of the limits specified on the next page.

Pump Specifications

U.S. Measurements

	Max. Flow	Nominal / Intermittent Pressure	Max. Speed	Power Req'd.	Max. Temp.	Plunger Diameter	Stroke	NPSH Required
Model	GPM	PSI	RPM	BHP	F	in	in	Ft-Head
P327	2.9	3500 / 4000	3450	7.0 / 8.0	160	0.47	0.42	n/a
P314	3.8	3500 / 4000	3450	9.2 / 10.5	160	0.47	0.56	n/a
P321	3.8	3200 / 3500	3450	8.4 / 9.2	160	0.47	0.56	n/a
P318	4.8	2000	1450	6.6	160	0.79	0.56	n/a
P324	4.8	2200	1450	7.3	160	0.79	0.56	n/a
P318	5.8	1000	1750	4.0	160	0.79	0.56	n/a
P324	5.8	1100	1750	4.4	160	0.79	0.56	n/a

Metric Measurements

	Max. Flow	Nominal / Intermittent Pressure	Max. Speed	Power Req'd.	Max. Temp.	Plunger Diameter	Stroke	NPSH Required
Model	L/min	Bar	RPM	kW	C	mm	mm	mWs
P327	11.0	240 / 275	3450	5.2 / 6.0	70	12	10.6	n/a
P314	14.4	240 / 275	3450	6.9 / 7.8	70	12	14.1	n/a
P321	14.4	220 / 240	3450	6.3 / 6.9	70	12	14.1	n/a
P318	18.2	140	1450	4.9	70	20	14.1	n/a
P324	18.2	150	1450	5.4	70	20	14.1	n/a
P318	22.0	70	1750	3.0	70	20	14.1	n/a
P324	22.0	75	1750	3.3	70	20	14.1	n/a

Horsepower Ratings:

We recommend a 1.15 service factor be specified when selecting an electric motor as the power source. To compute electric motor horsepower required, use the following formula: $HP = (GPM \times PSI) / 1450$. The formula to determine the horsepower required for a gas engine is: $HP = (GPM \times PSI) / 1150$. The formula to determine the horsepower required for a diesel engine is: $HP = (GPM \times PSI) / 1250$.

For the Application of a Hydraulic Motor:

To Determine the Torque of a Hydraulic Motor -- $(GPM \times PSI \times 36.77) / RPM = \text{Torque (in-lbs)}$

Calculating RPM / GPM of Pump:

A pump must be connected to an electric motor or gas or diesel engine with the correct ratio of pulleys and belts to attain the required speed and GPM. The use of a Variable Frequency Drive (VFD) may also be used to control the RPM of a properly sized electric motor when variable flows are required.

$$(\text{Max. Pump RPM} / \text{Rated Pump GPM}) \times \text{Required Pump GPM} = \text{Required Pump RPM}$$

To calculate a pulley diameter one (1) pulley diameter and the required pump RPM must be known:

$$(\text{Pump RPM} \times \text{Pump Pulley Diameter}) / \text{Motor RPM} = \text{Motor Pulley Diameter}$$

$$(\text{Motor RPM} \times \text{Motor Pulley Diameter}) / \text{Pump RPM} = \text{Pump Pulley Diameter}$$

Common Specifications:

Inlet Pressure 145 PSI (10 Bar)
 Crankshaft Diameter..... 0.94" (24mm)
 Oil Capacity (short)..... 14.2 fl. oz. (0.42 L)
 Oil Capacity (extended)..... 17.0 fl. oz. (0.5 L)
 Inlet Ports (2) 1/2" BSP
 Discharge Ports..... (2) 3/8" BSP
 Weight 16 lbs (7.3 kg)
 Shaft Rotation Top of Pulley Towards Fluid End

Materials Used for P300 Pumps:

Manifold Forged Brass
 Plungers Solid Ceramic Oxide
 Valves..... High Grade Stainless Steel
 Seals..... Nitrile with Fabric Reinforcing
 Gear End Aluminum Die-Cast

Exploded View - P300 Series - 12 and 20mm

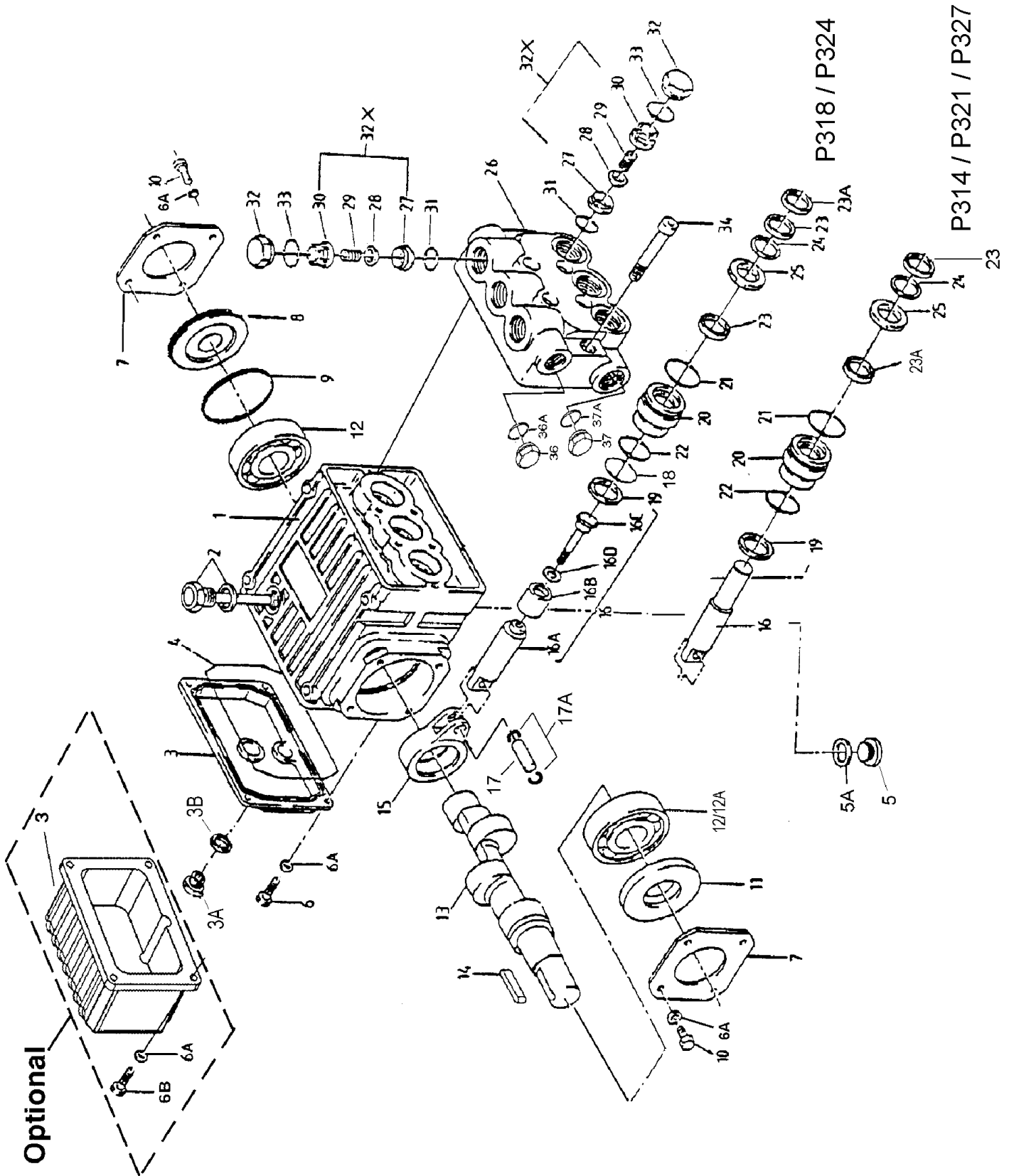

P300 SERIES PARTS LIST

A = P321

B = P314

C = P318

D = P324

E = P327

<u>ITEM</u>	<u>PART#</u>	<u>DESCRIPTION</u>	<u>QTY.</u>	<u>ITEM</u>	<u>PART NO.</u>	<u>DESCRIPTION</u>	<u>QTY.</u>
1	08326	Crankcase	1	17A	22723	Clip Ring	6
2	06773	Dipstick Assembly	1	18	07770	O-Ring (C,D)	3
3	08410B	Crankcase Cover, Short	1	19	08356-0010	Oil Seal	3
3	08410-LG	Crankcase Cover, Extended	1	20	08414	Seal Case (A,B,E)	3
3A	07190	Oil Drain Plug	1	20	08357	Seal Case (C,D)	3
3B	13262A	Gasket for Plug	1	21	07234	O-Ring (A,B,E)	3
4	08328	O-Ring	1	21	07780	O-Ring (C,D)	3
5	06273	Oil Drain Plug	1	22	12027	O-Ring	3
5A	08192	Gasket	1	23	07391	Grooved Seal Ring (A,B,E)	3
6	07188	Screw, Short Cover	4	23	08358	Grooved Seal (C,D)	6
6A	01176-2	Spring Washer	12	23A	08598	Grooved Seal (A,B,E)	3
6B	01196	Screw, Long Cover	4	24	07392	Pressure Ring (A,B,E)	3
7	08303	Bearing Cover I	2	24	08346	Pressure Ring (C,D)	3
8	08491	Sight Glass	1	25	08417	Weep Return Ring (A,B,E)	3
9	07193	O-Ring	1	25	08361	Weep Return Ring (C,D)	3
10	07225	Screw with Lock Washer	8	26	06556	Valve Casing (A,B,E)	1
11	08331	Radial Shaft Seal	1	26	06413*	Valve Casing (C,D)	1
12	01086	Ball Bearing (A,C)	2	27	07849	Valve Seat	6
12	01086A	Ball Bearing (B,D,E)	1	28	07491	Valve Plate	6
12A	07760	Roller Bearing (B,D,E)	1	29	07906	Valve Spring	6
13	08332	Crankshaft (A,B,C,D)	1	30	07907	Valve Spring Retainer	6
13	08478	Crankshaft (E)	1	31	07853	O-Ring	6
14	06207	Straight Key	1	32	06546	Valve Plug (A,B,E)	6
15	08333	Connecting Rod	3	32	06350*	Valve Plug (C,D)	6
16	08413	Plunger Assembly, 12mm (A,B,E)	3	32X	07946A	Valve Assembly, Complete	6
16	08452	Plunger Assembly, 20mm (C,D)	3	33	07913	O-Ring	6
16A	08367	Plunger Base (C,D)	3	34	08363	Hex Head Cap Screw	6
16B	08449	Plunger Pipe (C,D)	3	36	13338	Plug, 3/8" BSP	1
16C	08450	Tension Screw (C,D)	3	36A	08486	Copper Crush Washer, 3/8"	1
16D	08451	Copper Washer (C,D)	3	37	07109	Plug, 1/2" BSP	1
17	06542	Wrist Pin	3	37A	07661	Seal	1

*For P318 pumps manufactured prior to 5/98, Item 26=08362 & Item 32=07928

P300 SERIES REPAIR KITS

Plunger Packing Kits

P314/P321/P327 - # 09152

<u>Item</u>	<u>Part #</u>	<u>Description</u>	<u>Qty.</u>
23	07391	Grooved Seal Ring	3
23A	08598	Grooved Seal	3
24	07392	Pressure Ring	3

P318/P324 - # 09145

<u>Item</u>	<u>Part #</u>	<u>Description</u>	<u>Qty.</u>
23	08358	Grooved Seal	6
24	08346	Pressure Ring	3

Valve Assembly Kit - # 09116

<u>Item</u>	<u>Part #</u>	<u>Description</u>	<u>Qty.</u>
31	07853	O-Ring	6
32X	07946A	Valve Assembly	6
33	07913	O-Ring	6

Oil Seal Kit - # 09144

<u>Item</u>	<u>Part #</u>	<u>Description</u>	<u>Qty.</u>
19	08356-0010	Oil Seal	3

Torque Specifications

<u>Position</u>	<u>Item#</u>	<u>Description</u>	<u>Torque Amount</u>
3A	07190	Oil Drain Plug w/ Gasket	222 in.-lbs. (25 NM)
6/6B	07188/1196	Screw	43 in.-lbs (5 NM)
10	07225	Screw with Lock Washer	85 in.-lbs. (9.6 NM)
16C	08450	Tension Screw, Plunger	220 in.-lbs. (25 NM)
32	06350/06546	Plug	59 ft.-lbs. (80 NM)
34	08363	Hex Head Cap Screw, Valve Casing	222 in.-lbs.(25 NM)

Pump Mounting Selection Guide

<p>Bushings 01074 - 24 mm Tapered H Bushing</p>	<p>Rails 01160 Plated Steel Channel Rails (L=5.75"X W=1.0" x H=1.812") 01161 Plated Steel Channel Rails (L+5.75"x W+1.00"x H=2.50") 01163 Retro-Fit Rail (L=12" x W=1.5" x H=3")</p>
<p>Pulley & Sheaves 01061 - 7.75" Cast Iron 1 gr. - AB Section 01062 - 7.75" Cast Iron - 2 gr. - AB Section</p>	

TROUBLESHOOTING GUIDE

<u>MALFUNCTION</u>	<u>CAUSE</u>	<u>REMEDY</u>
The Pressure and/ or the Delivery Drops	Worn packing seals Broken valve spring Belt slippage Worn or Damaged nozzle Fouled discharge valve Fouled inlet strainer Worn or Damaged hose Worn or Plugged relief valve on pump Cavitation Unloader	Replace packing seals Replace spring Tighten or Replace belt Replace nozzle Clean valve assembly Clean strainer Repair/Replace hose Clean, Reset, and Replace worn parts Check suction lines on inlet of pump for restrictions Check for proper operation
Water in crankcase	High humidity Worn seals	Reduce oil change interval Replace seals
Noisy Operation	Worn bearings Cavitation	Replace bearings, Refill crankcase oil with recommended lubricant Check inlet lines for restrictions and/or proper sizing
Rough/Pulsating Operation with Pressure Drop	Worn packing Inlet restriction Accumulator pressure Unloader Cavitation	Replace packing Check system for stoppage, air leaks, correctly sized inlet plumbing to pump Recharge/Replace accumulator Check for proper operation Check inlet lines for restrictions and/or proper size
Pressure Drop at Gun	Restricted discharge plumbing	Re-size discharge plumbing to flow rate of pump
Excessive Leakage	Worn plungers Worn packing/seals Excessive vacuum Cracked plungers Inlet pressure too high	Replace plungers Adjust or Replace packing seals Reduce suction vacuum Replace plungers Reduce inlet pressure
High Crankcase Temperature	Wrong Grade of oil Improper amount of oil in crankcase	Giant oil is recommended Adjust oil level to proper amount

Preventative Maintenance Check List & Recommended Spare Parts List						
Check	Daily	Weekly	50 hrs	Every 500 hrs	Every 1500 hrs	Every 3000 hrs
Oil Level/Quality	X					
Oil Leaks	X					
Water Leaks	X					
Belts, Pulley		X				
Plumbing		X				
Recommended Spare Parts						
Oil Change p/n 01153			X	X		
Plunger Seal Kit (1 kit/pump)					X	
Oil Seal Kit (1 kit/pump)					X	
Valve Repair Kit (1 kit/pump)						X

REPAIR INSTRUCTIONS - P300 SERIES

NOTE: Always take time to lubricate all metal and nonmetal parts with a light film of oil before reassembly. This step will ensure proper fit, at the same time protecting the pump nonmetal parts (i.e., the elastomers) from cutting and scoring.

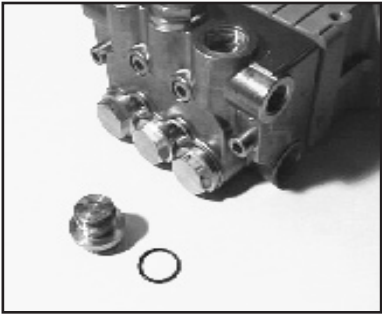

1. With a 24mm socket wrench, remove the (3) discharge valve plugs and (3) inlet valve plugs (#32). Inspect the o-ring (#33) for wear and replace if damaged.

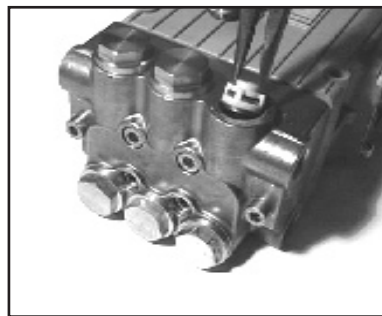

2. Using a needle nose pliers, remove the inlet and discharge valve assemblies (#32X).

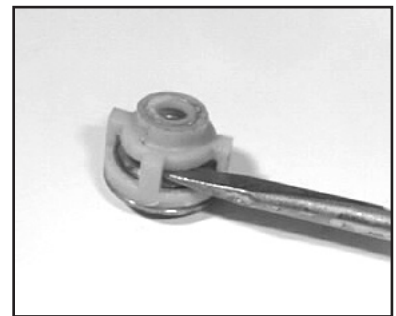

3. The valve assemblies can be separated by inserting a small screw driver between the valve seat (#27) and its valve spring retainer (#30).



4. Remove each o-ring (#31). Inspect all parts for wear and replace as necessary. Reassemble valve assy's (32X) & place in valve casing (26).

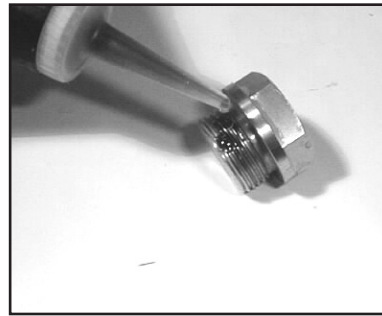

5. Apply one drop of Loctite 243 to valve plugs (32) and tighten to 59 ft.-lbs. For pumps manufactured prior to 5/97 tighten plugs to 37 ft.-lbs.

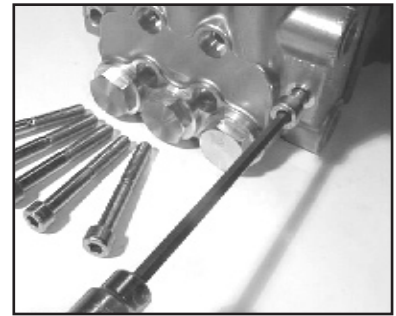

6. Next, use a 6mm allen wrench to remove the 6 hex head cap screws (#34).



7. Carefully slide the valve casing (#26) out over the plungers with a screwdriver placed between the valve casing and crankcase.



8. Remove weep return rings (#25) from the plungers (#16). Remove the seal case (#20) from either crankcases (#1) or manifold (#26) by using a screwdriver as shown above.

NOTE: If there are deposits of any kind (i.e., lime deposits) in the valve casing, be certain the weep holes in the weep return ring (#25) and valve casing (#26) have not been plugged.

REPAIR INSTRUCTIONS - P300 SERIES

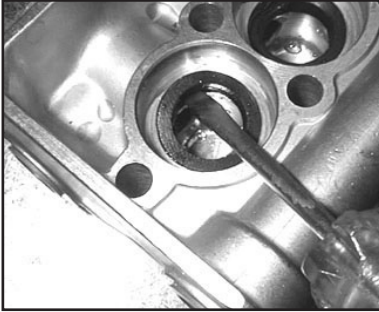

9. Remove the pressure rings (#24) and grooved seals (#23) from the valve casing (#26). Inspect parts for wear and replace if necessary. For P318 & P324 only, the spacers (#23A) can now be removed.



10. Remove the weep grooved seals (23A for all pumps except P318/P32 & #23 for P318/P324 only) from the seal case (#20).



11. Inspect o-rings (#21 and 22) and replace as necessary.



12. For all pumps (except P318/P324), use a flat screw driver to pry the oil seals (#19) loose from the seal case (#20).

For P318/P324 Pumps

Note: Occasionally, this procedure can be carried out for P318/P324 pumps. However, for P318/P324 pumps which have the oil seals that remain in the crankcase, use a 6mm allen wrench to first loosen and remove the tension screw (#16C) from the plunger pipes (#16B). Use a flat screwdriver to pry the oil seals loose from the crankcase (#1).



13. Check surfaces of the plunger bases and plunger pipes (#16B). A damaged surface will cause accelerated wear on the seals. Deposits of any kind must be carefully removed from the plunger surface. A damaged plunger must be replaced!

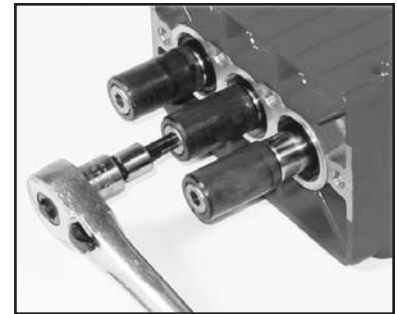

- 13A. **P318/P324 Only!** Clean the old sealant from the threads of the tension screw and the plunger base (16A). Place plunger pipes over plunger base and secure with tension screw to 220 in-lbs.

REPAIR INSTRUCTIONS - P300 SERIES

Reassembly sequence of the P300 Series pump

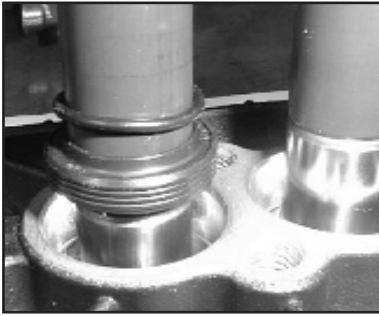

14. If the oil seals (#19) were removed, replace them with the primary seal lip (grooved side) towards the crankcase and the dust lip (tapered end) towards the valve casing (#26). Lubricate the seal before replacing. Install the oil scraper (#18) over the plunger.
15. Place each seal case (#20) with o-rings (#21, 22) over the plungers (#16). Be certain the oil seal is centered with the seal case and tap firmly until the seal case is seated squarely on the crankcase (#1).
16. With the grooved side pointed toward the valve casing, place the weep grooved seals (23A for all pumps except P318/P324 & #23 for P318/P324 only) over each plunger and into each seal case (#20).
17. Generously lubricate the grooved seals (#23) and assemble these items into the valve casing. Place the weep return rings (#25) onto each plunger (#16). Place the pressure rings (#24) over the plungers. Slide the valve casing over the plungers and seat firmly. Replace the 6 hex head cap screws (#34) and tighten to 216 in.-lbs. in a crossing pattern.

Contact Giant Industries or you local distributor for maintenance of the gear end of your pump. Phone: 419/531-4600

P300 SERIES DIMENSIONS - INCHES (mm)

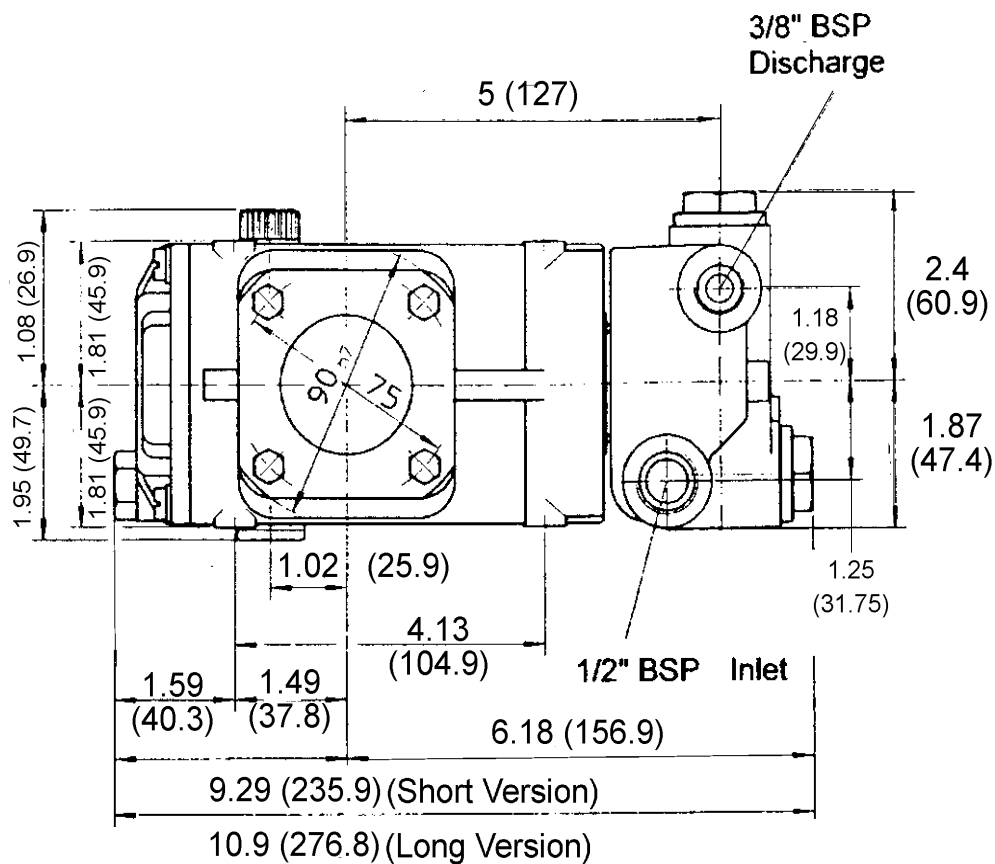
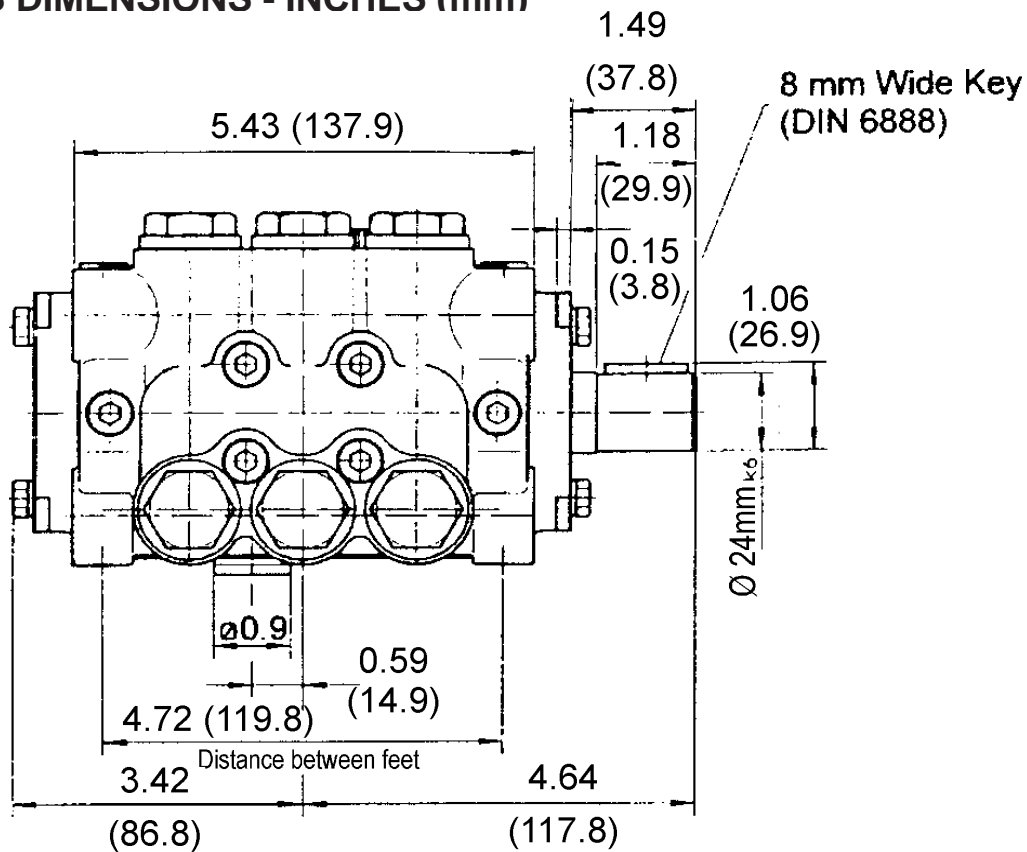

GIANT INDUSTRIES LIMITED WARRANTY

Giant Industries, Inc. pumps and accessories are warranted by the manufacturer to be free from defects in workmanship and material as follows:

1. For portable pressure washers and self-service car wash applications, the discharge manifolds are guaranteed for the life of the pump. Our other pump parts, used in portable pressure washers and in car wash applications, are warranted for five years from the date of shipment for all pumps used in NON-SALINE, clean water applications.
2. One (1) year from the date of shipment for all other Giant industrial and consumer pumps.
3. Six (6) months from the date of shipment for all rebuilt pumps.
4. Ninety (90) days from the date of shipment for all Giant accessories.

This warranty is limited to repair or replacement of pumps and accessories of which the manufacturer's evaluation shows were defective at the time of shipment by the manufacturer. The following items are NOT covered or will void the warranty:

1. Defects caused by negligence or fault of the buyer or third party.
2. Normal wear and tear to standard wear parts.
3. Use of repair parts other than those manufactured or authorized by Giant.
4. Improper use of the product as a component part.
5. Changes or modifications made by the customer or third party.
6. The operation of pumps and or accessories exceeding the specifications set forth in the Operations Manuals provided by Giant Industries, Inc.

Liability under this warranty is on all non-wear parts and limited to the replacement or repair of those products returned freight prepaid to Giant Industries which are deemed to be defective due to workmanship or failure of material. A Returned Goods Authorization (R.G.A.) number and completed warranty evaluation form is required prior to the return to Giant Industries of all products under warranty consideration. Call (419)-531-4600 or fax (419)-531-6836 to obtain an R.G.A. number.

Repair or replacement of defective products as provided is the sole and exclusive remedy provided hereunder and the MANUFACTURER SHALL NOT BE LIABLE FOR FURTHER LOSS, DAMAGES, OR EXPENSES, INCLUDING INCIDENTAL AND CONSEQUENTIAL DAMAGES DIRECTLY OR INDIRECTLY ARISING FROM THE SALE OR USE OF THIS PRODUCT.

THE LIMITED WARRANTY SET FORTH HEREIN IS IN LIEU OF ALL OTHER WARRANTIES OR REPRESENTATION, EXPRESS OR IMPLIED, INCLUDING WITHOUT LIMITATION ANY WARRANTIES OR MERCHANTABILITY OR FITNESS FOR A PARTICULAR PURPOSE AND ALL SUCH WARRANTIES ARE HEREBY DISCLAIMED AND EXCLUDED BY THE MANUFACTURER.



GIANT INDUSTRIES, INC., 900 N. Westwood Ave., P.O. Box 3187, Toledo, Ohio 43607
PHONE (419) 531-4600, FAX (419) 531-6836, www.giantpumps.com
© Copyright 2008 Giant Industries, Inc.