

Model LP121HT

Triplex Ceramic
Plunger Pump
Operating Instructions/
Repair and Service
Manual

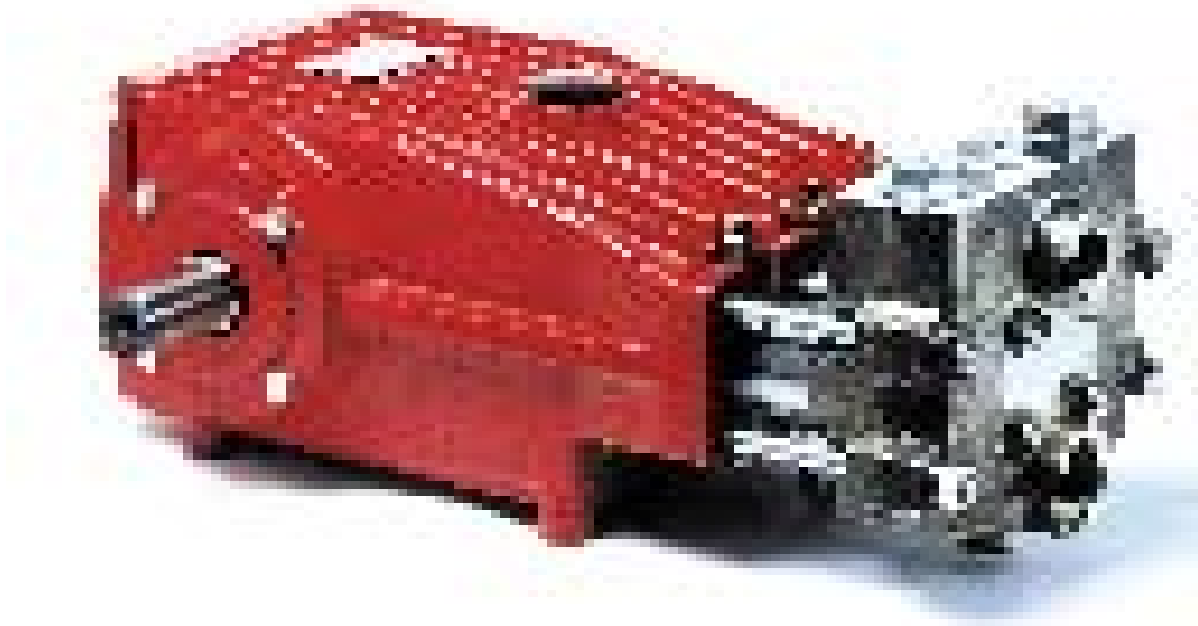

GIANT

Contents:

Installation Instructions:	page 2
Pump Specifications:	page 3
Exploded View:	page 4
Parts List / Kits:	page 5
Torque Specifications:	page 5
Operating Instructions:	page 6
Repair Instructions:	pages 7
Dimensions:	back page
Warranty Information:	back page

Updated 3/98

INSTALLATION INSTRUCTIONS

Installation of the Giant Industries, Inc., pump is not a complicated procedure, but there are some basic steps common to all pumps. The following information is to be considered as a general outline for installation. If you have unique requirements, please contact Giant Industries, Inc. or your local distributor for assistance.

1. The pump should be installed flat on a base to a maximum of a 15 degree angle of inclination to ensure optimum lubrication.
2. The inlet to the pump should be sized for the flow rate of the pump with no unnecessary restrictions that can cause cavitation. Teflon tape should be used to seal all joints. If pumps are to be operated at temperatures in excess of 221° F, it is important to insure a positive head to the pump to prevent cavitation. **See Page 6**
3. The discharge plumbing from the pump should be properly sized to the flow rate to prevent line pressure loss to the work area. It is essential to provide a safety bypass valve between the pump and the work area to protect the pump from pressure spikes in the event of a blockage or the use of a shut-off gun.

4. Use of a dampener is necessary to minimize pulsation at drive elements, plumbing, connections, and other system areas. The use of a dampener with Giant Industries, Inc. pumps is optional, although recommended by Giant Industries, Inc. to further reduce system pulsation. Dampeners can also reduce the severity of pressure spikes that occur in systems using a shut-off gun. A dampener must be positioned downstream from the unloader.

5. Crankshaft rotation on Giant Industries, Inc. pumps should be made in the direction designated by the arrows on the pump crankcase. Reverse rotation may be safely achieved by following a few guidelines available upon request from Giant Industries, Inc. Required horsepower for system operation can be obtained from the chart on page 3.

6. Before beginning operation of your pumping system, remember: Check that the crankcase and seal areas have been properly lubricated per recommended schedules. Do not run the pump dry for extended periods of time. Cavitation will result in severe damage. Always remember to check that all plumbing valves are open and that pumped media can flow freely to the inlet of the pump.

Finally, remember that high pressure operation in a pump system has many advantages. But, if it is used carelessly and without regard to its potential hazard, it can cause serious injury.

IMPORTANT OPERATING CONDITIONS

Failure to comply with any of these conditions invalidates the warranty.

1. Prior to initial operation, add oil to the crankcase so that oil level is between the two lines on the oil dipstick. **DO NOT OVERFILL.**

Use SAE 90 Industrial Gear Oil.

Crankcase oil should be changed after the first 50 hours of operation, then at regular intervals of 500 hours or less depending on operating conditions.

2. Pump operation must not exceed rated pressure, volume, or RPM. A pressure relief device must be installed in the discharge of the system.

3. Acids, alkalines, or abrasive fluids cannot be pumped unless approval in writing is obtained before operation from Giant Industries, Inc.

4. Run the pump dry approximately 10 seconds to drain the water before exposure to freezing temperatures.

Specifications LP121HT Pump

Volume	Up to 17.6 GPM
Discharge Pressure	Up to 1200 PSI
Inlet Pressure	Up to 90 PSI
Speed	Up to 570 RPM
Plunger Diameter	36 mm
Stroke	40 mm
Crankcase Oil Capacity	116 fl.oz.
Temperature of Pumped Fluids	Up to 221 °F
Inlet Port	1" BSP
Discharge Port	1-1/4" BSP
Crankshaft Mounting	Either Side
Shaft Rotation	Top of Pulley Towards Fluid End
Weight	110 lbs.
Crankshaft Diameter	35 mm

PULLEY INFORMATION

Pulley selection and pump speed are based on a 1725 RPM motor and "B" section belts. When selecting desired GPM, allow for a ±5% tolerance on pumps output due to variations in pulleys, belts and motors among manufacturers.

1. Select GPM required, then select appropriate motor and pump pulley from the same line.
2. The desired pressure is achieved by selecting the correct nozzle size that corresponds with the pump GPM.

HORSEPOWER INFORMATION

Horsepower ratings shown are the power requirements for the pump. Gas engine power outputs must be approximately twice the pump power requirements shown above.

We recommend that a 1.1 service factor be specified when selecting an electric motor as the power source. To compute specific pump horsepower requirements, use the following formula:

$$(GPM \times PSI) / 1450 = HP$$

LP121HT PULLEY SELECTION AND HORSEPOWER REQUIREMENTS					
RPM	GPM	300 PSI	600 PSI	900 PSI	1200 PSI
200	6.2	1.3	2.6	3.8	5.1
300	9.3	1.9	3.8	5.8	7.7
400	12.4	2.6	5.1	7.7	10.2
500	15.5	3.2	6.4	9.6	12.8
570	17.6	3.7	7.3	11.0	14.6

EXPLODED VIEW - LP121HT PUMP

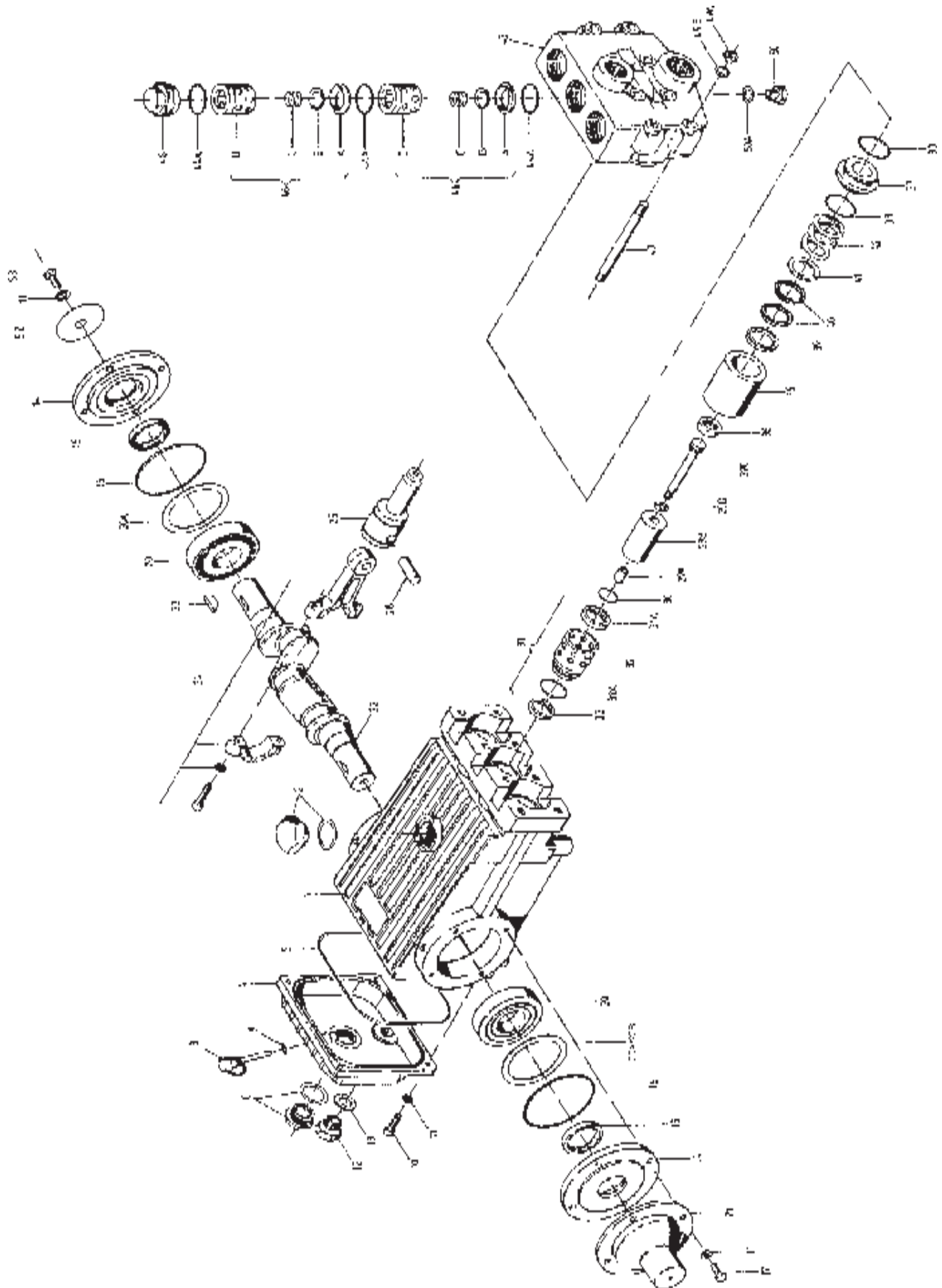

4PARTS LIST - LP121HT PUMP

Item	Part	Description	Qty.
1	07759	Crankcase	1

Part Description Qty.

PARTS LIST - LP121HT PUMP

Item	Part	Description	Qty.	Item	Part	Description	Qty.
1	07759	Crankcase	1	30	13233	Flinger	3
2	13000	Oil Filler Plug Assy.	1	31	06120	Seal Retainer, Complete (#31A, 32, 32A, & 33)	3
4	06085	Crankcase Cover	1	31A	06118	Oil Seal	3
5	07104	O-Ring	1	32	06116	Oil Seal Retainer	3
6	07186	Oil Sight Glass Assy.	1	32A	06119	O-Ring	3
8	06086	Oil Dipstick Assy.	1	33	06117	Backup Seal	3
9	01009	O-Ring	1	35	07135	Seal Sleeve	3
10	01010	Screw	4	36	13291	Leakage Seal	3
11	01011	Spring Washer	12	37	07139	Seal Case	3
12	07109	Oil Drain Plug	1	38	07140	O-Ring	6
13	07182	Gasket	1	39	07142	Pressure Ring	3
14	07111	Bearing Cover	2	40	13199	V-Sleeve	6
15	07112	Crankshaft Seal	2	41	07146	Support Ring	3
16	07113	O-Ring	2	42	07147	Tension Spring	3
17	07114	Hex Screw	8	43	13018	Valve Casing	1
20	07116	Taper Roller Bearing	2	44A	07150	O-Ring	9
20A	07117	Shim	1-3	46A	07064	Valve Seat	6
20B	13001	Shim	1-3	46B	07063	Valve Plate	6
21	07118	Shaft Protector	1	46C	07062	Valve Spring	6
22	07119	Crankshaft	1	46D	07066	Spring Retainer	6
23	07120	Key	1	48	07156	Plug	3
24	07121	Connecting Rod Assy.	3	49	07157	Stud Bolt	8
25	07123	Crosshead Plunger Base Assy.	3	49A	07158	Nut	8
28	07124	Crosshead Pin	3	49B	07159	Washer	8
29A	07125	Sleeve	3	50	07423	Plug	1
29B	07736	Plunger Pipe	3	50A	07161	Gasket	1
29C	07131	Plunger Bolt	3	52	13020	Disc for Crankshaft	1
29D	07755	Copper Gasket	3	53	13021	Hexagon Screw	1

LP121HT PUMP REPAIR KITS

Plunger Packing Kit #09310			Valve Assembly Kit #09196		
Qty.	Part No.	Description	Qty.	Part No.	Description
3	13291	Leakage Seal	1	07064	Valve Seat
6	07140	O-Ring	1	07063	Valve Plate
6	13199	V-Sleeve	1	07062	Valve Spring

LP121HT PUMP TORQUE SPECIFICATIONS

Position	Item#	Description	Torque Amount
24	07121	Connecting Rod Screws	310 in.-lbs.
29C	07131	Plunger Bolt	33 ft.-lbs.
48	07156	Valve Plug	107 ft.-lbs.
49A	07158	Nut, Stud Bolt	59 ft.-lbs.

Supplementary Plant Lay-Out Instructions - LP121HT PUMP

Pressure in Inlet Side

The stipulated NPSHR is the minimum required pressure above the vapor pressure of the medium and is never to fall short of this figure. Temperature and vapor pressure of the medium, the geodetical height of the location, the flow rate and the loss of friction in the suction line, must all be taken into consideration. It may be necessary to install a booster pump (centrifugal) in the suction line.

Pulsation

Due to its construction, the plunger pump creates pulsation in the inlet and discharge lines. In particular, inlet pulsation must be dampened in order to prevent resonance in the suction line which in turn causes cavitation. Therefore, the pump is never to be connected by a rigid pipe. Rather, use a flexible hose, which is not reinforced by steel, that is 1.5 to 2 times wider than the inlet port. If a booster pump is used, the hose is to be attached between the booster pump and the high pressure pump.

If several pumps are used, each pump must have its own inlet line. If this cannot be done, an inlet air chamber or inlet flow stabilizer must be installed in front of each pump. The bladder in the stabilizer is to be pre-tensioned on location.

Depending on the layout of the plant, a pressure accumulator may be necessary on the discharge side. The pressure accumulator must be installed right behind the discharge outlet of the high pressure pump. Only use one pressure accumulator (in the discharge line) at a time in order to avoid irritation which could be caused by different pretension levels in the accumulators.

Gas-tension in both the inlet flow stabilizer and the pressure accumulator are to be checked regularly.

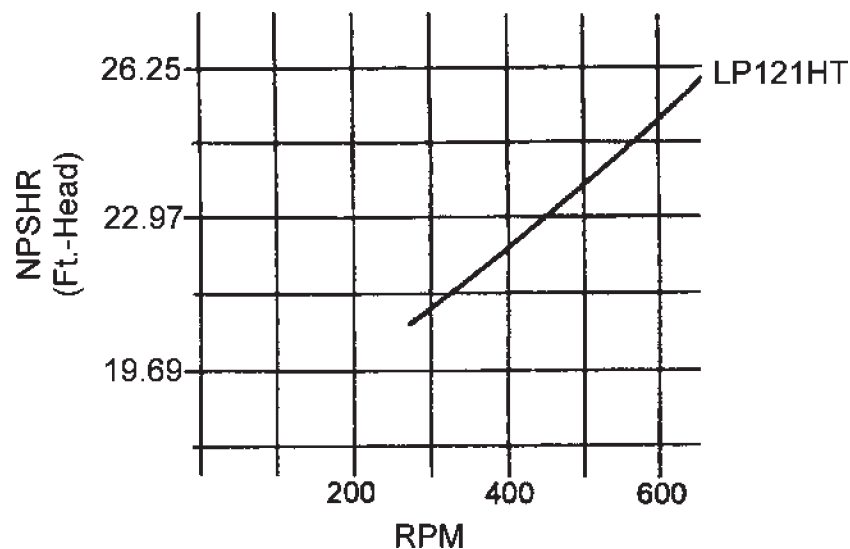

REPAIR INSTRUCTION - LP121HT PUMP

To Check Valves

Loosen valve plugs (48). Either with needle nose pliers or with a M12 screw, which can be threaded into the hole of the spring retainer (46D), take out discharge and inlet valve assemblies. Press onto the valve plate (46B) and twist to take apart the valve assembly. Check and replace worn parts. Tighten the plug to 107 ft.-lbs.

To Check Seals and Plungers

Loosen the eight nuts (49A) and take off the valve casing (43). Remove the seals (40) on the valve casing. Take seal sleeve (35) out of the guides in the crankcase (1) and remove the leakage seals (36).

Check plunger pipes (29B) for damage and remove any dirt. When replacing plunger pipes, use new copper rings (29D). Apply loctite on threads of plunger bolts (29C) and tighten to 33 ft.-lbs.

Check seals and replace as necessary.

Place new v-sleeves (40) along with support rings (41) in the valve casing (43). Place seals (36) and pressure rings (39) in seal sleeve (35). Install the complete unit in the valve casing. Finally, fit in the complete pump head assembly carefully over the plunger pipes and evenly tighten nuts to 59 ft.-lbs.

To Dismantle Gear End

After removing the valve casing (1) and plunger pipes (29B), drain the oil. Take off crankcase cover (4) and bearing cover (14). Loosen connecting rod screws (24) and push the connecting rod/plunger base assembly forward (as far as possible) into the crosshead guides. **Caution: Connecting rods are marked for identification. Do not twist connecting rod halves. Connecting rods are to be reinstalled in the same position on the crankshaft journals.** Turning the crankshaft (22) slightly, hit it out carefully to the side with a rubber hammer. **Caution: Do not bend the connecting rod shanks. Check crankshaft and connecting rod surfaces, shaft seals (15) and taper roller bearings (20).**

To Reassemble

Using a soft tool, press in the outer bearing ring until the outer edge is aligned with the outer edge of the bearing hole. Take off bearing cover (14) together with shaft seal (15) and o-ring (16). Fit crankshaft (22) through bearing hole on the opposite side. Press in outer bearing and tension it inwards with the bearing cover (keeping the shaft in a vertical position and turning slowly so that the taper rollers of the bearings touch the edge of the outer bearing ring). Adjust axial bearing clearance to at least 0.1mm and a maximum of 0.15mm by placing fitting discs (20A and 20B) under the bearing cover. **Caution: After assembly, the crankshaft (22) should turn easily with very little clearance.** Tighten connecting rod screws (24) to 310 in.-lbs.

NOTE: Contact Giant Industries for Service School Information. Phone: (419)-531-4600

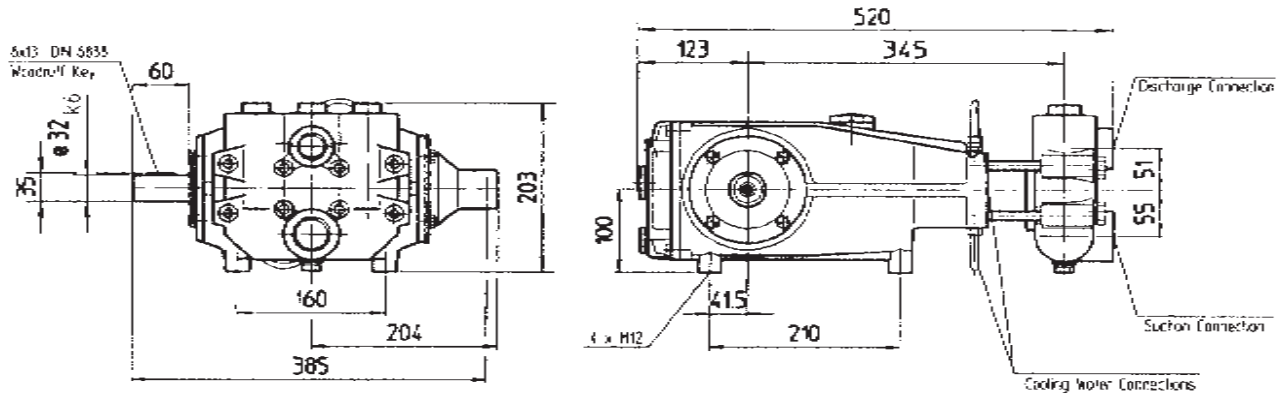

GIANT INDUSTRIES LIMITED WARRANTY

Giant Industries, Inc. pumps and accessories are warranted by the manufacturer to be free from defects in workmanship and material as follows:

1. For portable pressure washers and car wash applications, the discharge manifolds will never fail, period. If they ever fail, we will replace them free of charge. Our other pump parts, used in portable pressure washers and in car wash applications, are warranted for five years from the date of shipment for all pumps used in NON-SALINE, clean water applications.
2. One (1) year from the date of shipment for all other Giant industrial and consumer pumps.
3. Six (6) months from the date of shipment for all rebuilt pumps.
4. Ninety (90) days from the date of shipment for all Giant accessories.

This warranty is limited to repair or replacement of pumps and accessories of which the manufacturer's evaluation shows were defective at the time of shipment by the manufacturer. The following items are NOT covered or will void the warranty:

1. Defects caused by negligence or fault of the buyer or third party.
2. Normal wear and tear to standard wear parts.
3. Use of repair parts other than those manufactured or authorized by Giant.
4. Improper use of the product as a component part.
5. Changes or modifications made by the customer or third party.
6. The operation of pumps and or accessories exceeding the specifications set forth in the Operations Manuals provided by Giant Industries, Inc.

Liability under this warranty is on all non-wear parts and limited to the replacement or repair of those products returned freight prepaid to Giant Industries which are deemed to be defective due to workmanship or failure of material. A Returned Goods Authorization (R.G.A.) number and completed warranty evaluation form is required prior to the return to Giant Industries of all products under warranty consideration. Call (419)-531-4600 or fax (419)-531-6836 to obtain an R.G.A. number.

Repair or replacement of defective products as provided is the sole and exclusive remedy provided hereunder and the MANUFACTURER SHALL NOT BE LIABLE FOR FURTHER LOSS, DAMAGES, OR EXPENSES, INCLUDING INCIDENTAL AND CONSEQUENTIAL DAMAGES DIRECTLY OR INDIRECTLY ARISING FROM THE SALE OR USE OF THIS PRODUCT.

THE LIMITED WARRANTY SET FORTH HEREIN IS IN LIEU OF ALL OTHER WARRANTIES OR REPRESENTATION, EXPRESS OR IMPLIED, INCLUDING WITHOUT LIMITATION ANY WARRANTIES OR MERCHANTABILITY OR FITNESS FOR A PARTICULAR PURPOSE AND ALL SUCH WARRANTIES ARE HEREBY DISCLAIMED AND EXCLUDED BY THE MANUFACTURER.

