

Models

GP5136-5100 & GP5145-5100

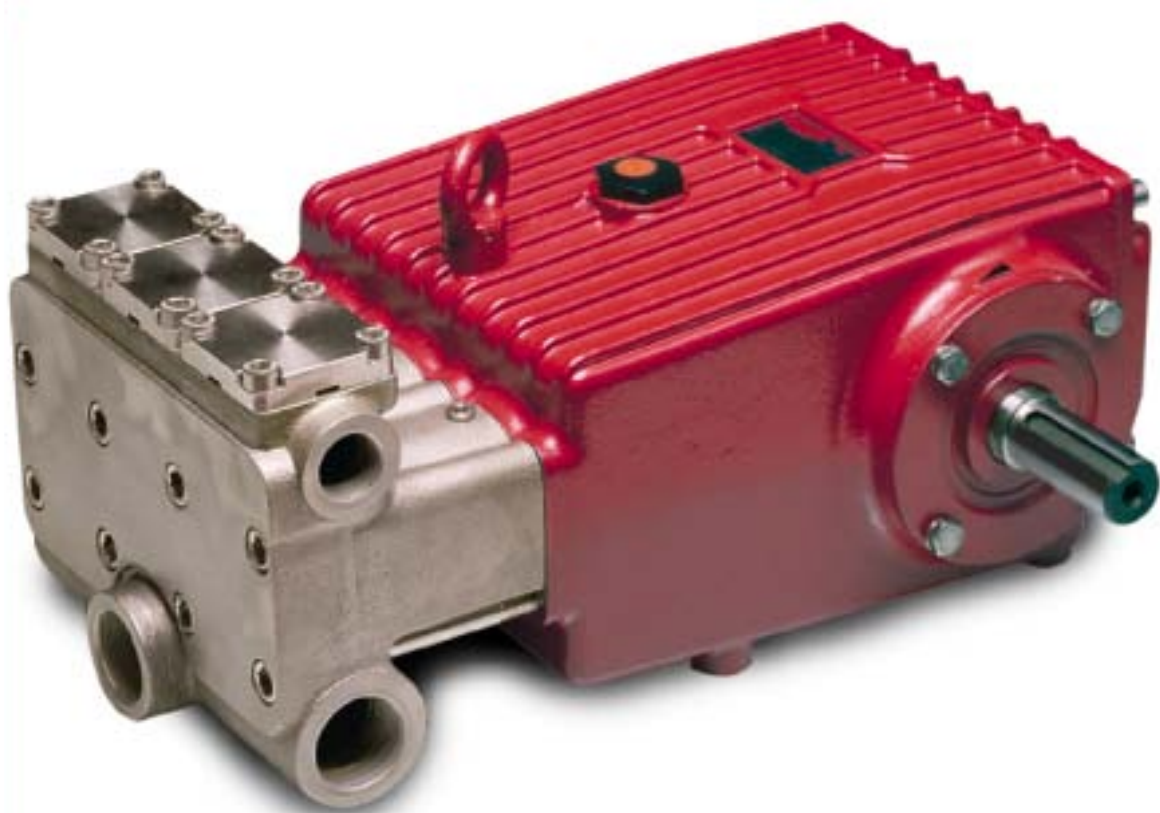

Contents:

Installation Instructions:	page 2
Pump Specifications:	pages 3-4
Kits/Torque Specs:	page 5
Recommended Maintenance:	page 5
Exploded View/Parts List:	pages 6-7
Trouble Shooting:	page 8
Repair Instructions:	pages 9-10
Dimensions:	page 11
Warranty Information	back page

INSTALLATION INSTRUCTIONS

Installation of the Giant Industries, Inc., pump is not a complicated procedure, but there are some basic steps common to all pumps. The following information is to be considered as a general outline for installation. If you have unique requirements, please contact Giant Industries, Inc. or your local distributor for assistance.

1. The pump should be installed flat on a base to a maximum of a 15 degree angle of inclination to ensure optimum lubrication.
2. The inlet to the pump should be sized for the flow rate of the pump with no unnecessary restrictions that can cause cavitation. Teflon tape should be used to seal all joints. If pumps are to be operated at temperatures in excess of 140° F, it is important to insure a positive head to the pump to prevent cavitation.
3. The discharge plumbing from the pump should be properly sized to the flow rate to prevent line pressure loss to the work area. It is essential to provide a safety bypass valve between the pump and the work area to protect the pump from pressure spikes in the event of a blockage or the use of a shut-off gun.
4. Use of a dampener is necessary to minimize pulsation at drive elements, plumbing, connections, and other system areas. The use of a dampener with Giant Industries, Inc. pumps is optional, although recommended by Giant

Industries, Inc. to further reduce system pulsation. Dampeners can also reduce the severity of pressure spikes that occur in systems using a shut-off gun. A dampener must be positioned downstream from the unloader.

5. Crankshaft rotation on Giant Industries, Inc. pumps should be made in the direction designated by the arrows on the pump crankcase. Reverse rotation may be safely achieved by following a few guidelines available upon request from Giant Industries, Inc. Required horsepower for system operation can be obtained from the charts on pages 3-4.

6. Before beginning operation of your pumping system, remember: Check that the crankcase and seal areas have been properly lubricated per recommended schedules. Do not run the pump dry for extended periods of time. Cavitation will result in severe damage. Always remember to check that all plumbing valves are open and that pumped media can flow freely to the inlet of the pump.

Finally, remember that high pressure operation in a pump system has many advantages. But, if it is used carelessly and without regard to its potential hazard, it can cause serious injury.

IMPORTANT OPERATING CONDITIONS

Failure to comply with any of these conditions invalidates the warranty

1. Prior to initial operation, add oil to crankcase so that oil level is between the two lines on the oil dipstick. **DO NOT OVERFILL. SAE 80 or SAE 90 Industrial Gear (p/n 01154) oil may be used.** Crankcase oil should be changed after the first 50 hours of operation, then at regular intervals of 500 hours or less depending on operating conditions.

2. Pump operation must not exceed rated pressure, volume, or RPM. A pressure relief device must be installed in the discharge of the system.

3. Acids, alkalines, or abrasive fluids cannot be pumped unless approval in writing is obtained before operation from Giant Industries, Inc.

4. Run the pump dry approximately 10 seconds to drain the water before exposure to freezing temperatures.

NOTE: Contact Giant Industries for Service School Information. Phone: (419)-531-4600

Specifications

Model GP5136-5100

Volume	33.8 GPM	127.8 LPM
Discharge Pressure	2320 PSI	160 Bar
Crankshaft Speed		910 RPM
Inlet Pressure	-4.35 to 145 PSI	-0.3 to 10 Bar
Plunger Diameter	1.42"	36mm
Plunger Stroke	1.81"	46mm
Crankshaft Diameter		35mm x 10mm key
Crankshaft Mounting		Either side
Shaft Rotation		Top of pulley towards manifold
Maximum Temperature of Pumped Fluids	140 °F	60 °C
Inlet Ports		(3) 1-1/2" BSP
Discharge Ports		(2) 1" BSP
Weight	179 lbs.	81 Kg
Crankcase Oil Capacity	1.2 Gal.	4.6 Liters
Fluid End Material		Nickel-plated spheroidal Cast Iron

Consult the factory for special requirements that must be met if the pump is to operate beyond one or more of the limits specified above.

GP5136-5100 Horsepower Requirements					
RPM	GPM	1000 PSI	1500 PSI	2000 PSI	2320
700	26.0	17.9	26.9	35.9	41.6
750	27.9	19.2	28.8	38.4	44.6
800	29.7	20.5	30.7	41.0	47.5
850	31.6	21.8	32.7	43.5	50.5
910	33.8	23.3	35.0	46.6	54.1

HORSEPOWER RATINGS:

The rating shown are the power requirements for the pump. Gas engine power outputs must be approximately twice the pump power requirements shown above.

We recommend a 1.15 service factor be specified when selecting an electric motor as the power source. To compute specific pump horsepower requirements, use the following formula:

$$HP = (GPM \times PSI) / 1450$$

SPECIAL NOTE:

FOR CONTINUAL OPERATION, THE SPEED OF THE PUMP MUST BE LIMITED TO 700 RPM, AND THE MAXIMUM PRESSURE OF THE PUMP MUST BE REDUCED BY 10%.

Specifications

Model GP5145-5100

Volume	43.5GPM	164.6LPM
Discharge Pressure.....	1450 PSI.....	100 Bar
Crankshaft Speed	750RPM	
Inlet Pressure	-4.35 to 145 PSI.....	-0.3 to 10 Bar
Plunger Diameter	1.77"	45mm
Plunger Stroke	1.81"	46mm
Crankshaft Diameter	35mm x 10mm key	
Crankshaft Mounting	Either side	
Shaft Rotation	Top of pulley towards manifold	
Maximum Temperature of Pumped Fluids	140 °F.....	60 °C
Inlet Ports	(3) 1-1/2" BSP	
Discharge Ports	(2) 1" BSP	
Weight	179 lbs.	81 Kg
Crankcase Oil Capacity	1.2 Gal.	4.6 Liters
Fluid End Material	Nickel-plated spheroidal Cast Iron	

Consult the factory for special requirements that must be met if the pump is to operate beyond one or more of the limits specified above.

GP5145-5100 Horsepower Requirements					
RPM	GPM	500 PSI	750 PSI	1000 PSI	1450 PSI
400	23.2	8.0	12.0	16.0	23.2
500	29.0	10.0	15.0	20.0	29.0
600	34.8	12.0	18.0	24.0	34.8
700	40.6	14.0	21.0	28.0	40.6
750	43.5	15.0	22.5	30.0	43.5

HORSEPOWER RATINGS:

The rating shown are the power requirements for the pump. Gas engine power outputs must be approximately twice the pump power requirements shown above.

We recommend a 1.15 service factor be specified when selecting an electric motor as the power source. To compute specific pump horsepower requirements, use the following formula:

$$HP = (GPM \times PSI) / 1450$$

SPECIAL NOTE:

FOR CONTINUAL OPERATION, THE SPEED OF THE PUMP MUST BE LIMITED TO 700 RPM, AND THE MAXIMUM PRESSURE OF THE PUMP MUST BE REDUCED BY 10%.

GP5136-5100 and GP5145-5100 Pumps Repair Kits

Plunger Packing Kits

GP5136-5100 (p/n 09597)

Item	Part #	Description	Qty.
35A	07303	O-Ring	6
35B	13286	O-Ring	3
36	13291-0020	Grooved Ring	3
37A	07910	O-Ring	6
39	07142-0100	Pressure Ring	3
40	07144	V-Sleeve	6

GP5145-5100 (p/n 09598)

Item	Part #	Description	Qty.
35A	13286	O-Ring	3
35B	08183	O-Ring	3
40	13294	Sleeve	6
40A	06146	Grooved Ring	3

Oil Seal Kit (p/n 09230)

Item	Part #	Description	Qty.
31	13284	Oil Seal	3

Valve Assembly Kits

Inlet Valve Kit (p/n 09231-0100)

Item	Part #	Description	Qty.
46A	12055	O-Ring	1
46C	13304-0100	Inlet Valve Assy.	1
46D	13306-0100	Valve Plate	1
46E	13307	Valve Spring	1
46F	13308	Spring Tension Cap	1
46G	13309	Spacer Pipe	1
48B	07740	O-Ring	1

Discharge Valve Kit (p/n 09232-0100)

Item	Part #	Description	Qty.
47A	13289	O-Ring	1
47C	13313	Discharge Valve Assy.	1
47D	13306-0100	Valve Plate	1
47E	13307	Valve Spring	1
47F	13308	Spring Tension Cap	1
48B	07740	O-Ring	1

GP5136-5100 & GP5145-5100 Pump Torque Specifications

Position	Item#	Description	Torque Amount (ft.-lbs)
24	13276	Connecting Rod Assy.	26
29C	07131-0100	Tension Screw, Plunger	26
48A	07008	Inner Hexagon Screw, Plug	35
49	13339	Inner Hexagon Screw, Valve Casing	85

Preventative Maintenance Check List & Recommended Spare Parts List						
Check	Daily	Weekly	50 Hrs.	Every	Every	Every
				500 Hours	1500 Hours	3000 Hours
Oil Level/Quality	X					
Oil Leaks	X					
Water Leaks	X					
Belts, Puelly		X				
Plumbing		X				
Recommended Spare Parts						
Oil Change (1 gallon) p/n 01154			X	X		
Plunger Seal Kit (1 kit/pump)					X	
Oil Seal Kit (1 kit/pump)					X	
Inlet and Valve Repair Kit (1 kit/pump)						X

Exploded View - GP5136-5100 and GP5145-5100 Pumps

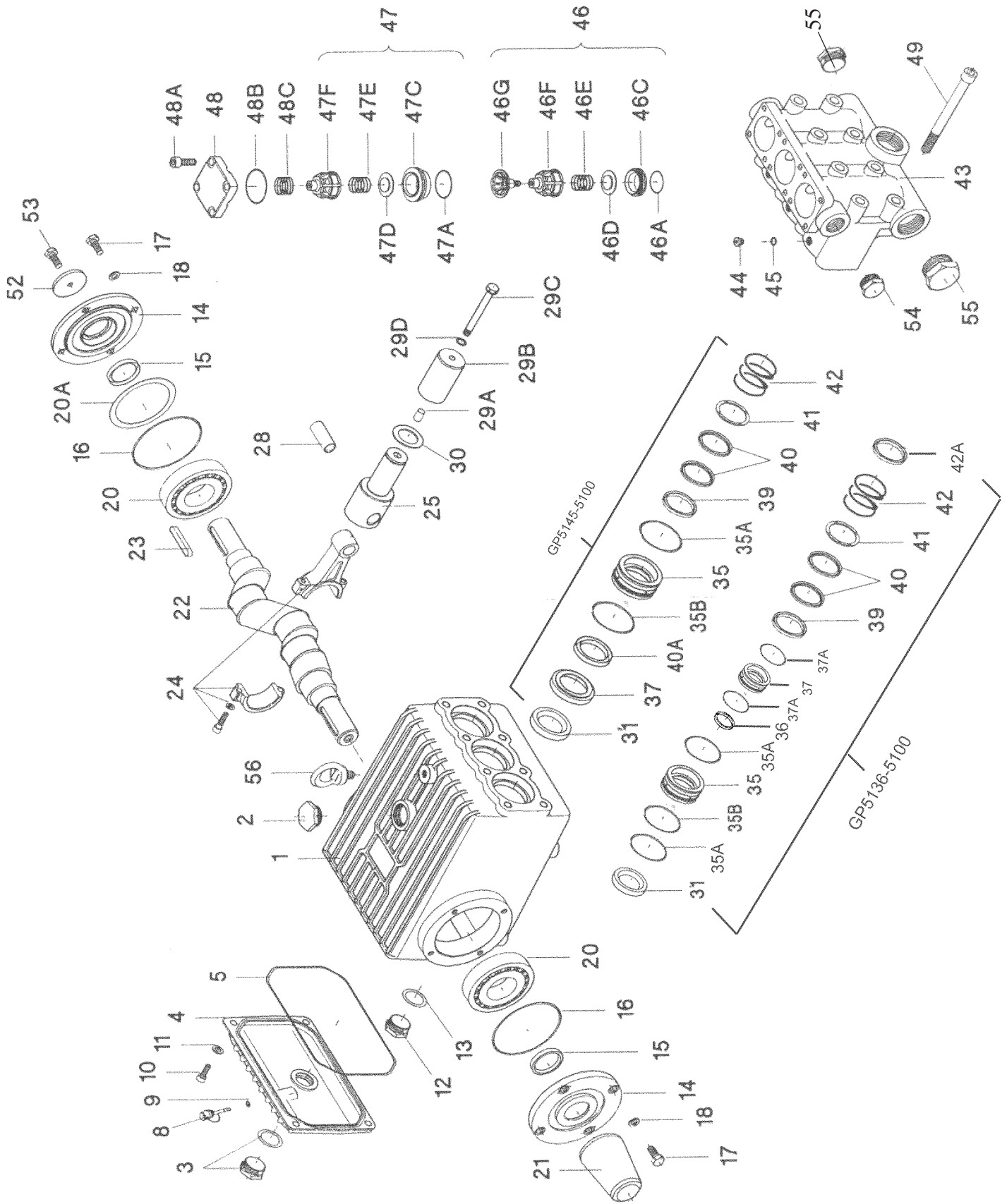

GP5136-5100 and GP5145-5100 Pumps Spare PARTS LIST

<u>ITEMPART</u>	<u>DESCRIPTION</u>	<u>QTY.</u>	<u>ITEMPART</u>	<u>DESCRIPTION</u>	<u>QTY.</u>	
1	13266	Crankcase	1	37A 07910	O-Ring (GP5136-5100 Only)	6
2	13000	Oil Filler Plug Assembly	1	39 07142-0100	Pressure Ring (GP5136-5100)	3
3	07841-0100	Oil Sight Glass Assy.	1	39 13292	Pressure Ring (GP5145-5100)	3
4	13267	Crankcase Cover	1	40 07144	V-Sleeve (GP5136-5100)	6
5	13268	O-Ring	1	40 13294	Sleeve (GP5145-5100)	6
8	07105	Oil Dip Stick	1	40A 06146	Grooved Ring	
9	01009	O-Ring, Dip Stick	1		(GP5145-5100 Only)	3
10	07008	Inner Hexagon Screw	4	41 07146-0100	Sleeve Support Ring	
11	06725	Spring Washer	4		(GP5136-5100)	3
12	07703	Drain Plug, 3/4" BSP	1	41 13295	Sleeve Support Ring	
13	13269	Gasket, Drain Plug	1		(GP5145-5100)	3
14	13271	Bearing Cover	2	42 07147	Tension Spring (GP5136-5100)	3
15	13272	Radial Shaft Seal	2	42 13297	Tension Spring (GP5145-5100)	3
16	08182	O-Ring	2	42A 13298-0100	Spring Guide (GP5136-5100 only)	3
17	13358	Hexagon Screw	8	43 13300-5000	Valve Casing, 316 S.S.	1
18	06725	Spring Washer	8	44 06589	Plug, 1/8" BSP	3
20	13206	Taper Roller Bearing	2	45 07204-0100	Steel Seal Ring	3
20A	13207	Fitting Disc (Shim)	5	46 13302-0100	Inlet Valve Assy.	3
21	13273	Shaft Protector	1	46A 12055	O-Ring	3
22	13274	Crankshaft	1	46C 13304-0100	Inlet Valve Seat	3
23	13275	Fitting Key	1	46D 13306-0100	Valve Plate	3
24	13276	Connecting Rod Assy.	3	46E 13307	Valve Spring	3
25	13280	Crosshead Assy.	3	46F 13308	Spring Tension Cap	3
28	13281	Crosshead Pin	3	46G 13309	Spacer Pipe	3
29A	07125	Centering Sleeve	3	47 13311-0100	Discharge Valve Assy.	3
29B	07130	Plunger Pipe (GP5136-5100)	3	47A 13289	O-Ring	3
29B	13283	Plunger Pipe (GP5145-5100)	3	47C 13313	Discharge Valve Seat	3
29C	07131-0100	Tension Screw	3	47D 13306-0100	Valve Plate	3
29D	07161-0100	Steel Ring	3	47E 13307	Valve Spring	3
30	13282	Oil Scraper	3	47F 13308	Spring Tension Cap	3
31	13284	Radial Shaft Seal	3	48 13316-0100	Plug	3
35	13288-0100	Seal Sleeve (GP5136-5100)	3	48A 07008	Inner Hexagon Screw	12
35	13287-0100	Seal Sleeve (GP5145-5100)	3	48B 07740	O-Ring	3
35A	07303	O-Ring (GP5136-5100)	6	48C 07232	Pressure Ring	3
35A	13286	O-Ring (GP5145-5100)	3	49 13339	Inner Hexagon Screw	8
35B	13286	O-Ring (GP5136-5100)	3	52 13362	Disc for Crankshaft	1
35B	08183	O-Ring (GP5145-5100)	3	53 13358	Hexagon Screw	1
36	13291-0020	Grooved Ring (GP5136-5100)	3	54 13321-0100	Plug, 1" BSP	1
37	06574-0100	Seal Case (GP5136-5100)	3	55 13322-0100	Plug, 1-1/2" BSP	2
37	06145-0100	Pressure Ring, Drip Return (GP5145-5100)	3	56 07623	Eye Bolt	1

PUMP SYSTEM TROUBLESHOOTING CHART		
MALFUNCTION	CAUSE	REMEDY
The Pressure and/ or the delivery Drops	Worn packing seals	Replace packing seals
	Broken valve springs	Replace springs
	Belt slippage	Tighten or replace belt
	Worn or Damaged nozzle	Replace nozzle
	Fouled discharge valve	Clean valve assembly
	Worn or plugged relief valve on pump	Clean, Reset, and Replace worn parts
	Cavitation	Check inlet lines of pump for restrictions or leakage
	Unloader	Check for proper operation
Water in Crankcase	High Humidity	Reduce oil change intervals
	Worn Seals	Replace seals
Noisy Operating	Worn bearings	Replace bearings, Refill crankcase with recommended oil
	Cavitation	Check inlet lines for restrictions and/or proper sizing
Rough/Pulsating Operation with Pressure Drop	Worn packing	Replace packing
	Inlet restriction	Check system for stoppage, air leaks, correctly sized inlet plumbing to pump
	Accumulator pressure	Recharge or replace accumulator
	Unloader	Check for proper operation
	Cavitation	Check inlet lines for restrictions and/or proper sizing
Pressure drop at gun	Restricted discharge plumbing	Re-size discharge plumbing to flow rate of pump
Excessive leakage	Worn plungers	Replace plungers
	Worn packing/seals	Adjust or replace packing seals
	Excessive vacuum	Reduce inlet vacuum
	Cracked plungers	Replace plungers
	Inlet pressure too high	Reduce inlet pressure
High Crankcase Temperature	Wrong Grade of Oil	Right oil is recommended
	Improper amount of oil in crankcase	Adjust oil level to proper amount

Repair Instructions - GP5136-5100 and GP5145-5100 Pumps

Note: Always take time to lubricate all metal and nonmetal parts with a light film of oil before reassembly. This step will ensure proper fit, at the same time protecting the pump's nonmetal parts (i.e., the elastomers) from cutting and scoring.

To Check Valves

1. Screw-out inner hexagon screws (48A) with an allen wrench. Remove discharge plugs (48) with a screw driver. Check o-rings (48B) on discharge plugs and replace as necessary.
2. Pull out pressure ring (48C). Remove the spring tension cap (47F) from the discharge valve plate (47D) lying underneath by screwing in the 10mm screw. Take out the valve spring (47E) and valve plate (47D). Pull out the discharge valve seat (47C) by means of slide hammer. Check sealing areas of the valve plate and the valve seat for damage and replace worn parts. Check o-rings (47A and 47B) and replace as necessary.
3. Screw spacer pipe (46G) out of the spring tension cap (46F) located in the suction valve lying underneath. Remove the suction valve assembly (46) by screwing in a 10mm screw. Check o-rings (46A and 46B) and replace as necessary. If the inlet valve seat (46C) remains in the valve casing (43), remove it with a slide hammer. Check the sealing areas of the inlet valve plate (46D) and the inlet valve seat (46C) for damage and replace worn parts.
4. After reassembling the above items, tighten the inner hexagon screws (48A) to 35 ft.-lbs.

To Check Seals and Plunger Pipes

1. Loosen the eight inner hexagon screws (49) and pull of the valve casing (43) to the front. Pull seal sleeves (35) out of the guides in the crankcase and over the plunger pipes (29B). Remove sleeve support ring (41), sleeves (40) and grooved rings (GP5136-5100 only) (36). Replace worn parts as necessary.
2. If a plunger pipe (29B) is worn out, loosen the tension screw (29C) and pull off the plunger pipe to the front. Clean the contact surfaces of the crosshead assembly (25) thoroughly. Place the new plunger pipe carefully through oiled seals back into the seal case. Check o-rings (35A and 35B as well as 37B in GP5136-5100 only) on the seal sleeves (35) and replace as necessary.
3. Push the Seal Sleeves (35) together with the plunger pipe (29B) back into the crankcase guide. Turn the crankshaft (22) carefully until the crosshead assembly (25) comes up against the plunger pipe. Put a new steel ring (29D) onto the tension screw (29C). Cover the thread of the tension screw and the oil scraper and apply a liquid adhesive such as lock-tite. Tighten tension screw to 26 ft.-lbs..

Important!!

Do not get any adhesive between the plunger pipe (29B) and the centering sleeve (29A). The plunger pipe should not be strained by excessive force on the tension screw (29C) or through damage to the front surface of the plunger. If these conditions are ignored, the plunger pipe will probably break.

4. Tighten the inner hexagon screws (49) to the valve casing (43) to 85 ft.-lbs.

Repair Instructions - GP5136-5100 and GP5145-5100 Pumps

To Disassemble Gear End

1. Loosen inner hexagon screws (49) for the valve casing (43) with an allen wrench. Carefully remove valve casing from the crankcase (1).
2. Drain oil from the crankcase (1) by removing drain plug (12) with a 3/4" wrench.
3. Loosen inner hexagon screws (10) for the crankcase cover (4) with an allen wrench and remove crankcase cover.
4. Loosen hexagon screws (17) for the bearing covers (14) with a wrench and remove bearing cover.
5. Loosen connecting rod screws (24) with an allen wrench. Push the stems of the connecting rods as far as possible into the crosshead guides. Carefully push out the radial shaft seals(31).

Important!!

Connecting rods (24) are marked for identification. Do not twist connecting rod halves. Connecting rods must be reinstalled in the same position on the crankshaft (22) journals.

6. While slightly turning the crankshaft (22), hit it out carefully to one side with a rubber hammer.

Important!!

Do not bend connecting rod (24) shank.

7. Check the surfaces of the crankshaft (22), connecting rods (24), crosshead assemblies (25) as well as the radial shaft seals (15 and 31) and taper roller bearings (20).

To Reassemble Gear End

1. Using a soft tool, such as brass or wooden dowel, press in the outer bearing ring until it lines up with the outer edge of the bearing hole. Assemble the bearing cover (14) together with the shaft seal (15) and o-ring (16).
2. Fit the crankshaft (22) with pressed-on bearing parts through the bearing hole on the opposite side. press in outer bearing ring and push it inwards with the bearing cover (14) while keeping the crankshaft in the vertical position and turning it slowly so that the taper rollers of the bearings touch the edge of the outer bearing ring.
3. Adjust axial bearing clearance with fitting discs (20A) which are 0.1mm each. The crankshaft (22) should turn easily with very little clearance. Tighten inner hexagon screws on the connecting rods (24) to 26 ft.-lbs..

Important!!

There should be enough clearance for the connecting rods (24) to move sideways a little on the journals.

Important!!

The 1/2" BSP connection in the crankcase serves the purpose of draining leakage water. The connection should not be closed. See the drawing below.

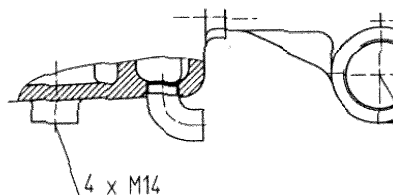

Pump Dimensions - GP5136-5100 and GP5145-5100 Pumps - Inches (mm)

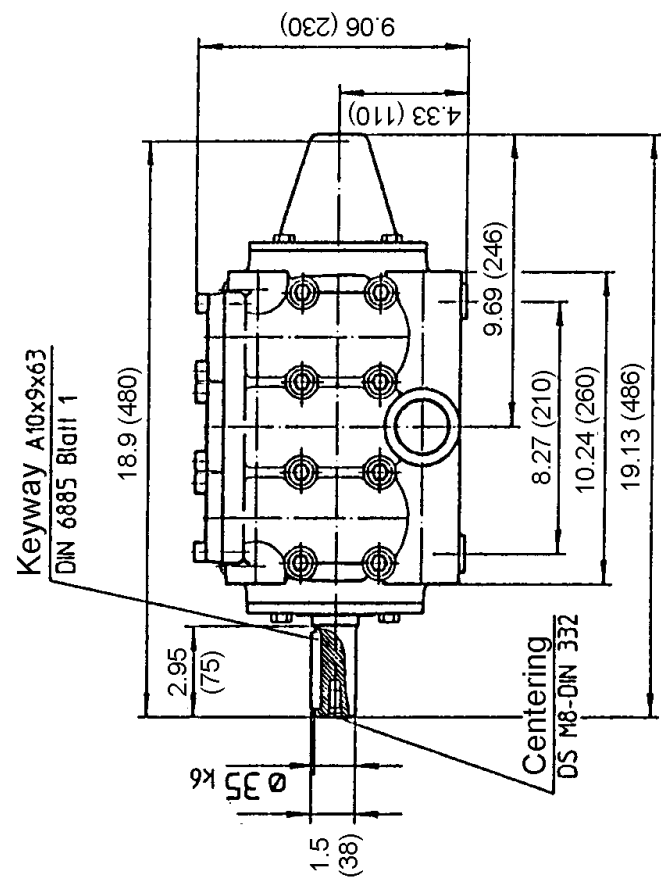
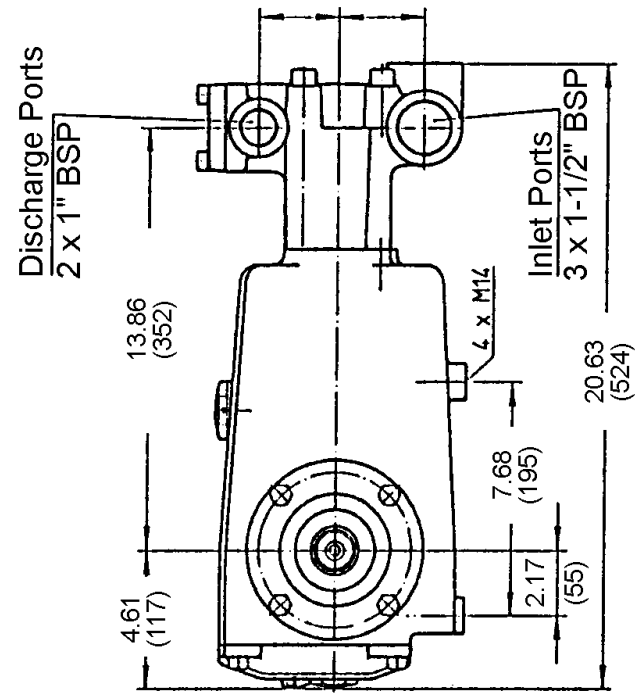

GIANT INDUSTRIES LIMITED WARRANTY

Giant Industries, Inc. pumps and accessories are warranted by the manufacturer to be free from defects in workmanship and material as follows:

1. For portable pressure washers and car wash applications, the discharge manifolds will never fail, period. If they ever fail, we will replace them free of charge. Our other pump parts, used in portable pressure washers and in car wash applications, are warranted for five years from the date of shipment for all pumps used in NON-SALINE, clean water applications.
2. One (1) year from the date of shipment for all other Giant industrial and consumer pumps.
3. Six (6) months from the date of shipment for all rebuilt pumps.
4. Ninety (90) days from the date of shipment for all Giant accessories.

This warranty is limited to repair or replacement of pumps and accessories of which the manufacturer's evaluation shows were defective at the time of shipment by the manufacturer. The following items are NOT covered or will void the warranty:

1. Defects caused by negligence or fault of the buyer or third party.
2. Normal wear and tear to standard wear parts.
3. Use of repair parts other than those manufactured or authorized by Giant.
4. Improper use of the product as a component part.
5. Changes or modifications made by the customer or third party.
6. The operation of pumps and or accessories exceeding the specifications set forth in the Operations Manuals provided by Giant Industries, Inc.

Liability under this warranty is on all non-wear parts and limited to the replacement or repair of those products returned freight prepaid to Giant Industries which are deemed to be defective due to workmanship or failure of material. A Returned Goods Authorization (R.G.A.) number and completed warranty evaluation form is required prior to the return to Giant Industries of all products under warranty consideration. Call (419)-531-4600 or fax (419)-531-6836 to obtain an R.G.A. number.

Repair or replacement of defective products as provided is the sole and exclusive remedy provided hereunder and the MANUFACTURER SHALL NOT BE LIABLE FOR FURTHER LOSS, DAMAGES, OR EXPENSES, INCLUDING INCIDENTAL AND CONSEQUENTIAL DAMAGES DIRECTLY OR INDIRECTLY ARISING FROM THE SALE OR USE OF THIS PRODUCT.

THE LIMITED WARRANTY SET FORTH HEREIN IS IN LIEU OF ALL OTHER WARRANTIES OR REPRESENTATION, EXPRESS OR IMPLIED, INCLUDING WITHOUT LIMITATION ANY WARRANTIES OR MERCHANTABILITY OR FITNESS FOR A PARTICULAR PURPOSE AND ALL SUCH WARRANTIES ARE HEREBY DISCLAIMED AND EXCLUDED BY THE MANUFACTURER.



GIANT INDUSTRIES, INC. 900 N. Westwood Ave., P.O. Box 3187, Toledo, Ohio 43607
Phone: (419)-531-4600 FAX (419)-531-6836, www.giantpumps.com
© Copyright 2004 Giant Industries, Inc.