



FLOJET

Diaphragm Pumps



Leading the way in small pump technology

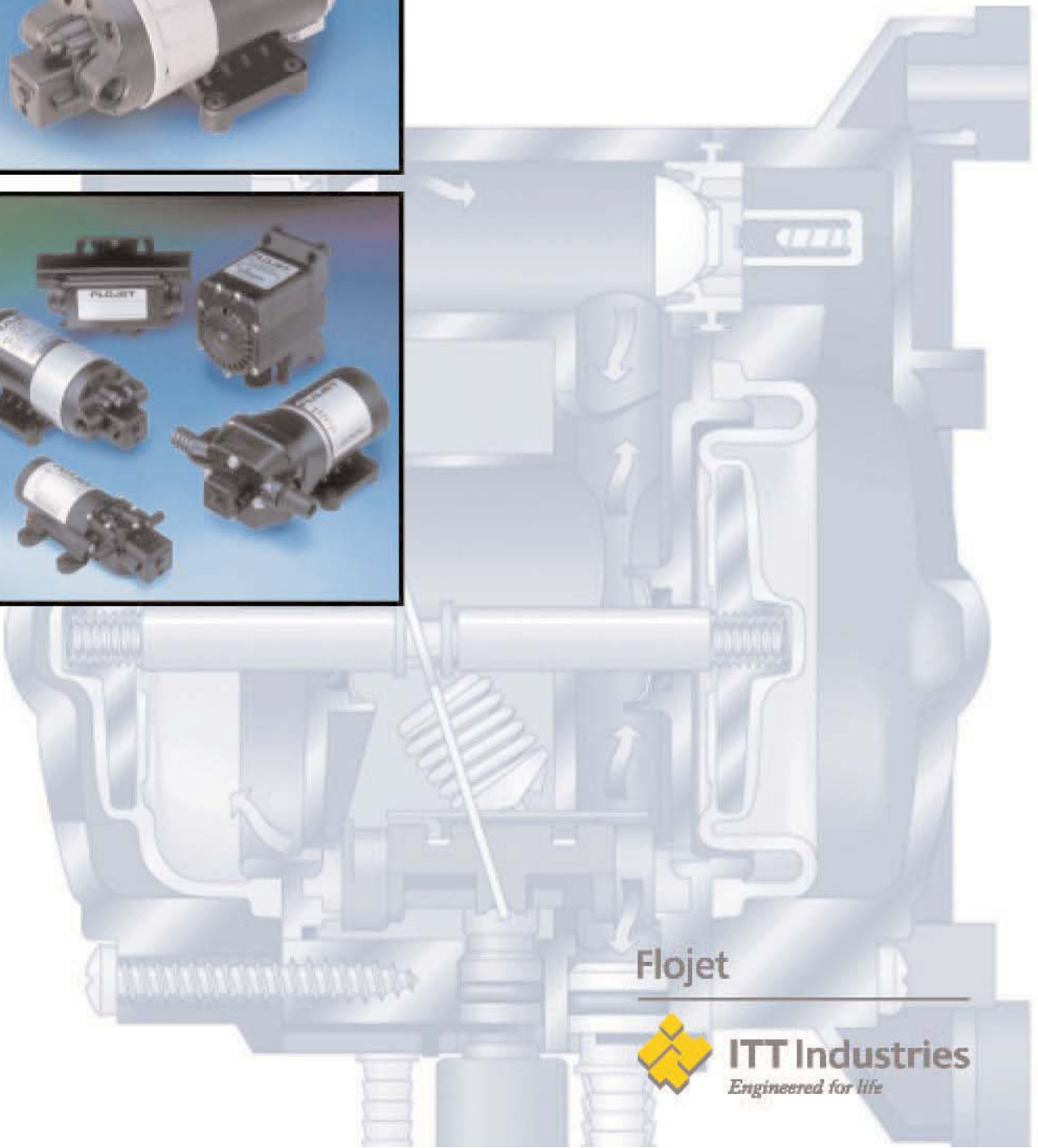

Flojet



ITT Industries
Engineered for life

A Full Line of Quality Positive Displacement Pumps

Application Capability of Flojet Product Range	
Maximum Flow	26 litres/minute
Maximum Fluid Viscosity	750 cP
Temperature of Fluids	0 to 60° C
Maximum Differential Pressure	0 to 7 bar

Flojet Diaphragm pumps are manufactured with a range of elastomers selected for their chemical compatibility

- Santoprene®
- EPDM
- Buna
- Geolast
- Viton® Viton is a registered trademark of Dupont Dow Elastomers

The Principle Behind Positive Displacement Diaphragm Pumps

Motor Driven

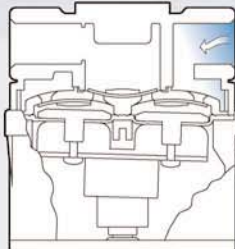

Self-priming design allows pumps to create suction to draw fluid into pump without manual priming.

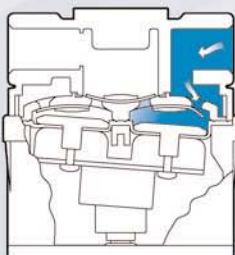

Fluid enters inlet port and is drawn through inlet check valve when piston moves away from the check valve.

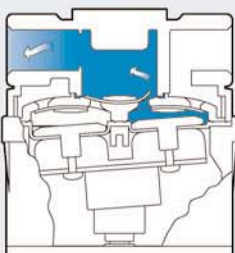

As piston moves toward the check valve assembly, the fluid is forced through the outlet check valve and out of the pump.

Air Driven

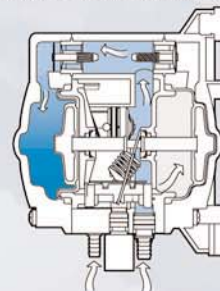

Air pressure directed by the stall-proof shuttle valve pulls the left diaphragm to create suction for the fluid being pumped.

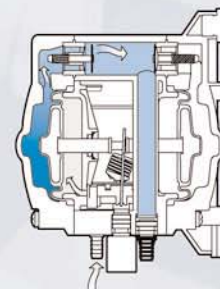

Pressurised air is redirected behind the left diaphragm, causing a discharge stroke, forcing the fluid out. At the same time the right diaphragm draws in more fluid.

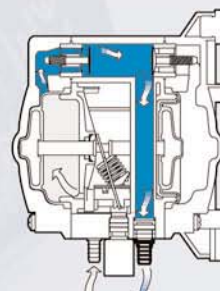

Air is redirected to the right side by the shuttle valve as it repeats the above cycle; forcing fluid out at the right diaphragm and drawing fluid in at the left.

Features and Benefits

Expect Only the Best

With over 25 years of pump design and manufacturing experience, Flojet is committed to delivering the hardest working, longest lasting pumps. No matter the application, Flojet can provide a superior pump to match all your requirements.

Self-Priming Even When Dry

- Dry vertical lift from 0.75 metres up to an outstanding 8.5 metres

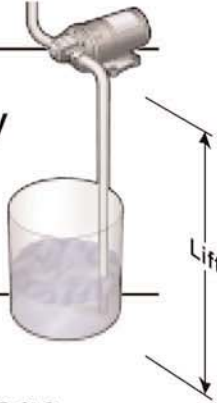

Can Run Dry Without Damage

- Flojet Diaphragm pumps can run dry for extended periods with no damage even when the liquid supply is exhausted



Compact Size and Lightweight

- Easy to install
- Highest flow rates for their size
- Plug-in ports for easy installation
- Flojet pumps mount easily anywhere with functional mounting platforms and simple connections - fit it anywhere and plumb it up

Easy, Low-Cost & Convenient Servicing

- Modular design
- Low cost, low maintenance design means a trouble-free service life
- Spare parts and accessories are readily available and easy to install

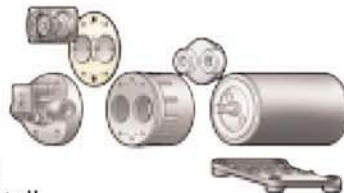

Compact and Lightweight Air Operated Pumps

Small in size, big on performance and value

- Self-priming
- Stall free
- Seal-less
- Demand controlled
- Can run dry without damage to pump



Motor Driven Pumps

The ultimate versatility in a heavy duty pump

- Permanent magnet motors and heavy duty ball bearings for the offset cam assembly that moves the reciprocating piston plate
- Optional pressure-actuated switch to provide on-demand switch or bypass for transfer or recirculating applications
- External bypass systems are perfect for applications with closed or partially closed discharge lines



Solenoid Pumps

Dependable and efficient

- Self-priming
- Double insulated
- Low Amp draw for cool operation
- Deliver fluids up to 90 litres/hour with pressures from 0 to 60 bar

FLOJET

Applications

Flojet offers a comprehensive selection of pumps and accessories for applications across a wide range of industries:

Agricultural Spray

Pest Control

Floor Care Equipment

Road Construction Equipment

Street Sweepers

Photographic Processing

Commercial Printing Machines

Medical Equipment

Water Purification

Automotive Service

Car Wash

Chemical Dispensing

Mixing

Dosing

Metering

Filtration



Medical
Equipment
Pumps



Floor Care
Equipment
Pumps



Industrial
Coolant and Lubricant
Pumps



Agriculture
Sprayer Pumps



Car Wash Foam, Soap
and Chemical Pumps

FLOJET

Electric Diaphragm Pumps

Flojet LF Low Flow Pump

Maximum Flow:	3.8 litres/min
Maximum Discharge Pressure:	2.4 bar
Self-Priming:	0.75 metres
Voltage:	12 and 24V DC Permanent-Magnet Motors
Temperature Range:	0 to 43°C

- Ultra compact two-chamber pumps deliver superior flow and pressure
- Low amp draw, perfect for battery powered applications
- Chemical-resistant polypropylene pump head for long pump life
- Built-in thermal protector for trouble-free operation
- Optional pressure-switch control, on/off switch and in-line fuse
- Choice of elastomer materials

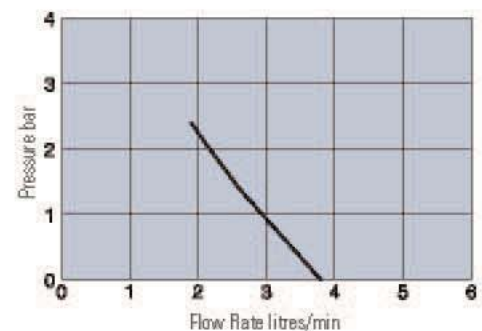
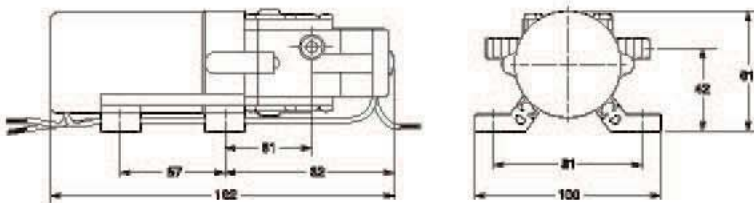

Flojet Duplex II Pump

Maximum Flow:	8.3 litres/min
Maximum Discharge Pressure:	7 bar
Self-Priming:	Minimum 2.4 metres
Voltage:	12, 24 and 36V DC, 115V and 230V AC Motors
Temperature Range	0 to 60°C
Handles Water-like and Viscous Liquids up to 250 cP	

- Chemical-resistant polypropylene pump head for long life
- Latest technology internal check-valves for reliable self-priming
- Choice of elastomers for maximum chemical compatibility
- Internal bypass for excellent performance range
- Optional pressure-switch control to run the pump only as needed
- Available with long running heavy duty motor with built-in thermal overload
- Available with commercial-duty DC motor for continuous operation

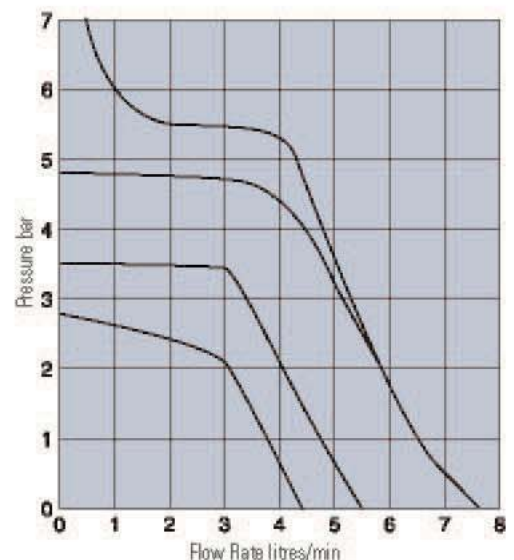
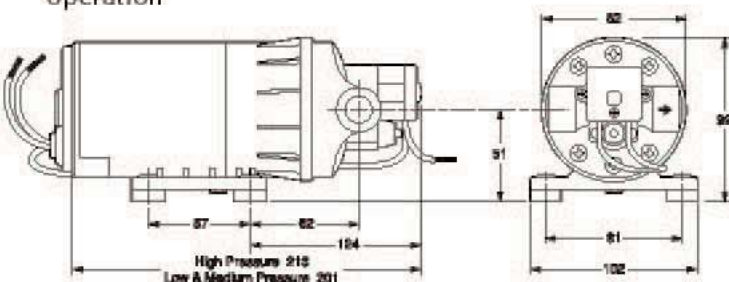

Electric Diaphragm Pumps cont.

Flojet Quad Pump

Maximum Flow:	19 litres/min
Maximum Discharge Pressure:	3.2 bar
Self-Priming:	2.4 metres
Temperature Range:	up to 54°C
Handles Water-Like and Viscous Liquids up to 250 cP	

- Four-piston design delivers higher flow rates
- Chemical-resistant polypropylene pump head for long life
- Choice of elastomeric materials to work with many chemicals
- Quick-connect plug-in ports for easy installation
- Optional pressure-switch control to run the pump only as needed

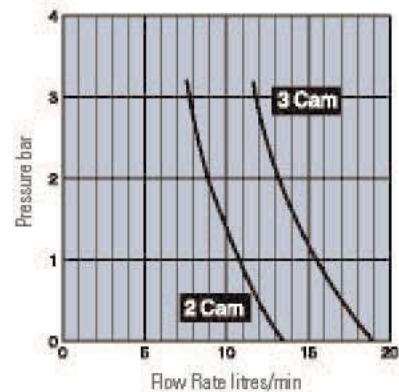
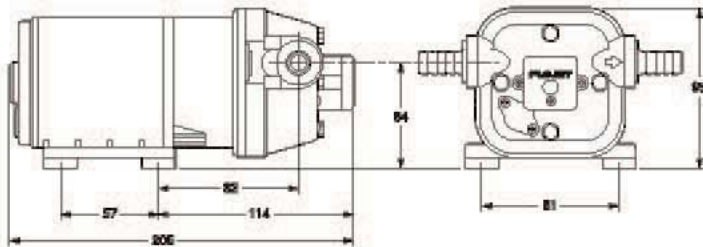

Air Operated Diaphragm Pumps

Flojet 5100 Air Operated Pump

Maximum Flow:	7.6 litres/min
Maximum Discharge Pressure:	5.5 bar
Self-Priming:	up to 8.5 metres
Temperature Range:	to 50°C
Handles Water-Like and Viscous Liquids up to 250 cP	

- Variable capacity from zero to maximum flow
- No risk of electric shock
- No pressure relief or by-pass valve required
- Variety of elastomers for valves and diaphragms available

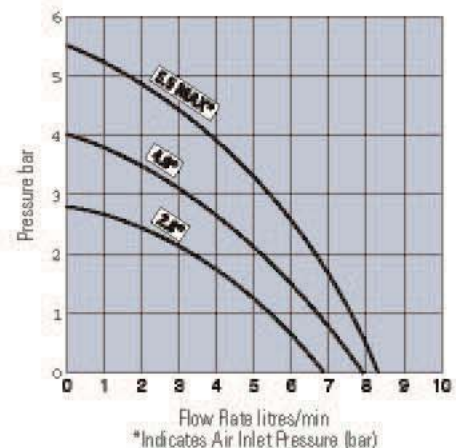
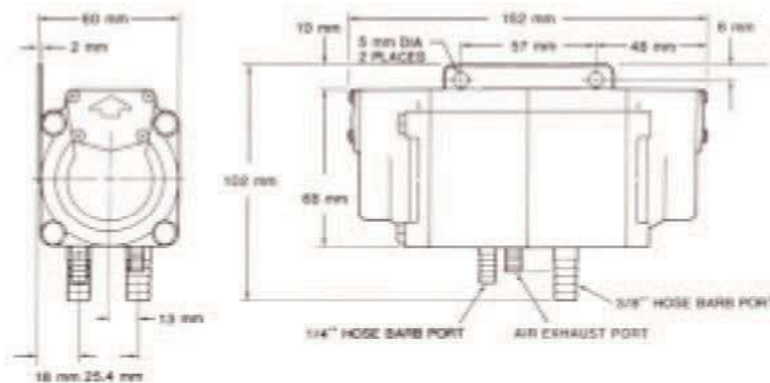

Air Operated Diaphragm Pumps cont.

Flojet G57 Pumps

Maximum Flow:	26.5 litres/min
Maximum Discharge pressure:	7 bar
Self-Priming:	up to 4.5 metres
Temperature Range:	up to 50°C
Handles Water-like and Viscous Liquids up to 750 CP	

- Highest flow rates for any air-driven pump of comparable size
- Stall-proof design with patented shuttle valve
- Quick disconnect parts for easy installation
- Sanitary design with insert molded diaphragm
- Leak resistant radial seals

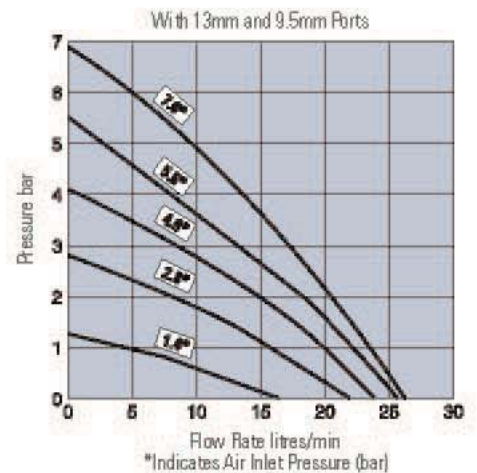
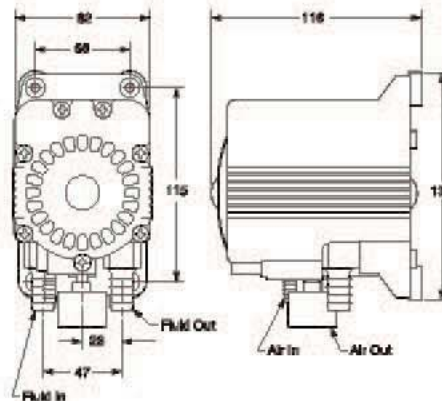

Electric Solenoid Pumps

Flojet Solenoid Pumps

Maximum Flow:	90 litres/hr
Maximum Discharge Pressure:	16 bar
Voltage:	Standard, 115V/60Hz and 230V/50Hz Other Voltages Available Upon Request
Temperature Range:	up to 80°C

- Self-Priming
- Double insulated
- Low amp draw
- Handles a broad range of liquids
- Ultra compact
- 1000 hours of continuous or intermittent use

508/500 Series

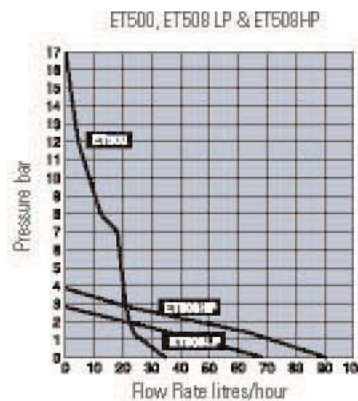
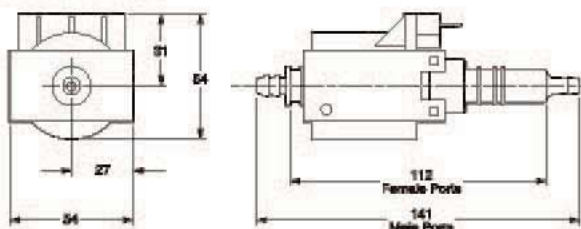

FLOJET



FLOJET offers a **comprehensive and unrivaled range** of specialised positive-displacement diaphragm pumps supplied to a diverse sector of industry worldwide including:

Agriculture
Floor Care
Car Wash
Automotive
Construction Equipment
Chemical Transfer
General Industrial

With more than 25 years of experience, Flojet has grown to an international corporation that employs many skilled professionals worldwide. **Flojet is renowned for manufacturing high quality products that utilise leading edge technology:** products that include small diaphragm pumps, motors, and electromechanical accessories. In 1999 Flojet was purchased by the world's largest pump manufacturer, ITT Industries. Flojet provides industry-leading personalised service, expedient delivery, and competitive prices to customers worldwide.

At Flojet, we pride ourselves on offering the industry's best customer service. We take your satisfaction seriously from the very beginning.

- Flojet's technical support group, marketing professionals and project engineers are on call and ready to help you select the best Flojet pump for your application.
- To make sure you'll get the pump that best matches your application requirements, we also maintain a dedicated team of research engineers, development engineers and designers assigned to work on application-specific projects.
- We assure on-time delivery of quality-tested products through stringent manufacturing process controls.
- You can count on Flojet for user-friendly support literature to make installation, service and trouble shooting easier.

Distributed By

Flojet



ITT Industries
Engineered for life

USA
Flojet
20 Icon
Foothill Ranch
CA 92610

Tel: +1 949 859 4945
Fax: +1 949 859 1153

UK
Jabsco
Bingley Road
Hoddesdon
Hertfordshire, EN11 0BU

Tel: +44 1992 450 145
Fax: +44 1992 467 132

Germany
Jabsco GmbH
Oststraße 28
22844 Norderstedt

Tel: +49 40 53 53 73 0
Fax: +49 40 53 53 73 11

Japan
NHK Jabsco Co Ltd
3-20-10, Shin-Yokohama
Kohoku-ku
Yokohama 222

Tel: +81 45 475 8906
Fax: +81 45 475 8908

Warranty: All products and services of Flojet ITT Industries are sold and or offered subject to the company's warranty terms and conditions of sale. Copies of which will be furnished upon request.

43011-0009