



SOTERA™

SYSTEMS

400B SERIES
DIAPHRAGM PUMP



In today's agricultural and industrial markets, isn't it good to know that you can rely on one name — Sotera — to fit your chemical transfer needs?

The Sotera 400B Series offers proven technology that combines the attributes of an air operated diaphragm pump with the convenience, portability, and efficiency of an electric driven design. It also uses less power than other conventional chemical pumps for maximum efficiency.

ONE-WAY VALVE FEATURE

Standard product inherently conforms to the EPA's 2011 mandate requiring that package designs don't allow back filling of totes or drums.

HEAVY-DUTY, RUGGED CONSTRUCTION

Glass-reinforced polypropylene pump body provides integrity and excellent material compatibility inside and out. It's the heart of our complete range of ready-to-use transfer systems.

OPTIMIZED FLUID COMPATIBILITY

Santoprene diaphragm for maximum chemical and corrosion resistance. Combined with strength and long life.

UNIQUE DESIGN

Improves fluid-handling capabilities with low material shear, solids handling up to 1/10", viscosity range of 0-3,000 cps, dry-run capability, and no internal bypass.

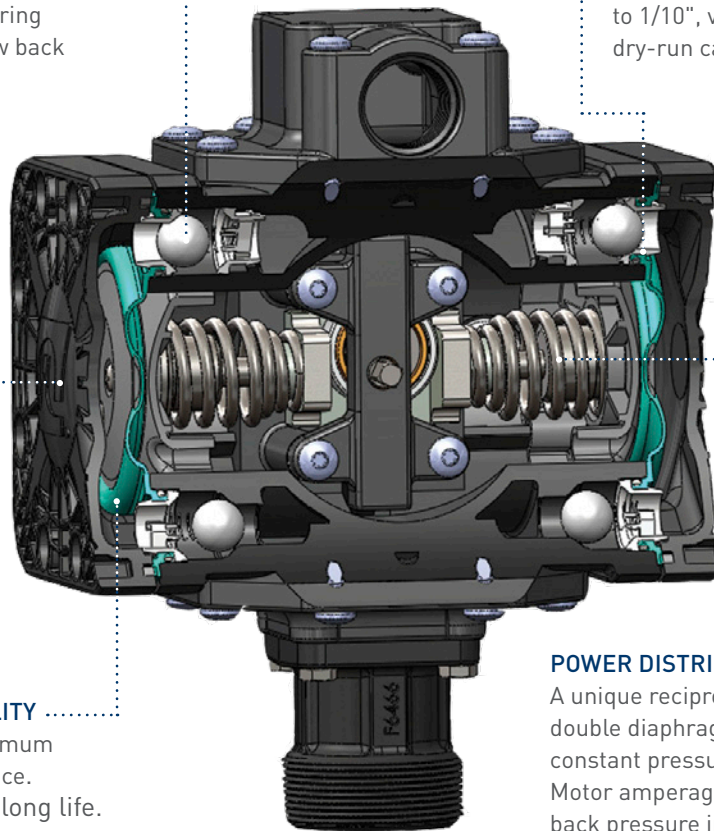

POWER DISTRIBUTION

A unique reciprocating, spring driven, double diaphragm configuration retains constant pressure, regardless the load. Motor amperage is actually reduced as back pressure increases. No internal bypass. Pump automatically goes neutral when end-of-hose valve is shut off.

SERIES 400B DUAL DIAPHRAGM CHEMICAL PUMP SPECIFICATIONS

Pump Specification		Construction Materials		Motor Specification
Reciprocating, spring driven dual diaphragm design		Pump: glass-filled polypropylene		115V AC, 12V DC, and 24V DC
Flow Rate	15 gpm (1.5 cps) 12 gpm (350 cps)	Internal wetted parts: glassfilled polypropylene, fluorocarbon, 304 stainless steel, EPDM or fluorocarbon wetted seals and Santoprene diaphragms		1/4 hp, 12 amps maximum draw (12V DC) with 20' DC cable, alligator clips, and a 30-amp fuse
Max Pressure	15 psi	Inlet port	1" NPT female	1/4 hp, 1.2 amps maximum draw (115V AC) with a heavy-duty 3-wire cable and plug
Max Lift / Water	10'	Outlet port	1" NPT female	Thermal overload protection
Max Operating Temperature	130° F	Particle tolerance up to 0.1" diameter		Quality ball-bearing motor construction

SERIES 400B DUAL DIAPHRAGM CHEMICAL PUMP MODELS

SS415B

12V DC, Santoprene diaphragm, 2" NPT bung adapter. For barrels.
Pump/motor and adapter only.



SS415BX670

12V DC, Santoprene diaphragm, 1" x 90° NPT ports. Pump/motor only.

SS415BEXPX670

12V DC, explosion proof, santoprene diaphragm, 1" NPT ports.
Pump/motor only.



SS415BX731

12V DC, Santoprene diaphragm, 2" NPT bung adapter integral to inlet.
For caged totes. Pump/motor only.

SS415BX731PG

12V DC, Santoprene diaphragm, fast and efficient, all items needed to pump from a tote or drum — DC version of SS460BX731PG. For caged totes.



SS417B

12V DC, Santoprene diaphragm, 2" NPT bung adapter integral to inlet, plus polypropylene telescoping suction tube. Top mounted on barrels or totes.



SS419BX665

12V DC, Hytrel diaphragm, Monsanto coupler, 12' EPDM hose and shutoff ball valve.



SS420B

12V DC, Santoprene diaphragm, 2" NPT connection, polypropylene telescoping suction tube, 12' EPDM hose, shutoff valve and nozzle retainer. For barrels.



SS435B

12V DC, Chemtraveller, portable tubular frame with top and bottom adapter kits, 825 meter, 9' EPDM inlet hose, 12' EPDM discharge hose, shutoff valve, and all connection fittings.



SS435BX675

12V DC, Chemtraveller, portable tubular frame with top and bottom adapter kits, 850 meter, 9' EPDM inlet hose, 12' EPDM discharge hose, shutoff valve, and all connection fittings.



SS435BX713

12V DC, Chemtraveller, portable tubular frame with top and bottom adapter kits, polypropylene telescoping suction tube, 9' EPDM inlet hose, 12' EPDM discharge hose, shutoff valve, and all connection fittings. For caged totes—top and bottom withdrawal.



SS435BEXPX703

12V DC, explosion proof, Chemtraveller, portable tubular frame with top and bottom adapter kits, 9' EPDM inlet hose, 12' EPDM discharge hose, shutoff valve, and all connection fittings.



SS445B

12V DC, Santoprene diaphragm, GemCap, and recirculation unit for chemical shutter, with 9" GemCap.



SS460B

115V AC, santoprene diaphragm — AC version of the SS420B.

SS460BX674

115V AC, santoprene diaphragm, and 90° flanged ports.

SS460BX731

115V AC, santoprene diaphragm, 2" NPT bung adapter, and motor bracket.

SS460BX731PG

115V AC, santoprene diaphragm, Pump-N-Go, and all items needed to pump from a tote or drum — AC version of SS415BX731PG.

SS465BEXP

115V AC explosion proof, Chemtraveller, portable tubular frame with top and bottom adapter kits, 825 meter, 9' EPDM inlet hose, 12' EPDM discharge hose, shutoff valve, and all connection fittings.

SS465BX713

115V AC, Chemtraveller, portable tubular frame with top and bottom adapter kits, 9' EPDM inlet hose, 12' EPDM discharge hose, shutoff valve, and all connection fittings.



The 800 Series Digital Meter is a nutating disc, positive displacement meter that's able to store and display the current flow amount (total) or the cumulative flow amount (totalizer) in any of six user-specified units.

- Rugged corrosion-resistant body for the most demanding applications.
- Quick one-step calibration.
- Easy to install and use in line or at the end of hose.
- Consistent accuracy up to $\pm 2\%$.
- Battery powered (2 AA batteries).

Applications

- Pesticides
- Fertilizers
- Water
- Crop oil
- Mild acids
- Diesel Exhaust Fluid
- Diesel fuel
- Mineral spirits
- Ethylene glycol
- Motor oil
- Gear oil
- Soaps /detergent
- Many others

Chemically resistant materials to meet the most versatile applications—one meter for many uses.

Materials

Body	Chamber	Seal Option	Display	Power Source	Calibration	Dimensions
Glass-filled polypropylene	Ryton/302SS	Fluorocarbons (std)/EPDM optional	LCD	(2) AA batteries	Ounces, pints, quarts, liters, gallons, user-specified units	5.5" x 3.25" x 5"



SERIES 825 (STANDARD MODEL)

Versatile meter for use in line, at the end of the hose, or mounted to one of our Rotary Vane or 400B Series Diaphragm Pumps.

Meter	Flow Rate	Max Pressure	Temperature Range	Flow Ports	Elastomers	Accuracy	Totalizer Range	Weight
825	2-20 gpm	125 psi	-10°F to 130°F	1" FNPT	Fluorocarbon	+/-0.5% using calibration factor; +/-0.2% using liquid calibration	9,999 current total, 10,000,000 accumulated total	3 lbs.
	7.6-75.7 lpm	8.3 bar	12°C to 54°C					
825X700	2-20 gpm	125 psi	-10°F to 130°F	1" FNPT	EPDM	+/-0.5% using calibration factor; +/-0.2% using liquid calibration	9,999 current total, 10,000,000 accumulated total	3 lbs.
	7.6-75.7 lpm	8.3 bar	12°C to 54°C					
825D075BSPPS	2-20 gpm	125 psi	-10°F to 130°F	3/4" BSPP	EPDM	+/-0.5% using calibration factor; +/-0.2% using liquid calibration	9,999 current total, 10,000,000 accumulated total	3 lbs.
	7.6-75.7 lpm	8.3 bar	12°C to 54°C					

SERIES 850 (MASS AIR SENSOR MODEL)

The 850 also includes a mass air sensor that distinguishes between fluid and air. That means the 850 stops metering when you've finished emptying a container, adding an extra degree of accuracy.



Meter	Flow Rate	Max Pressure	Temperature Range	Flow Ports	Accuracy	Totalizer Range	Weight
850	2-20 gpm	120 psi	-10°F to 130°F	1" NPT inlet/outlet ports, female threads	+/-0.5% using calibration factor; +/-0.2% using liquid calibration	9,999 current total, 10,000,000 accumulated total	3 lbs.



SOTERA[™]
SYSTEMS



Tuthill Transfer Systems
8825 Aviation Drive | Fort Wayne, Indiana 46809
P (800) 634-2695 | (260) 747-7524
F (800) 866-4861 | (260) 747-3159