



SERIES 400B DIAPHRAGM PUMP

For Chemical & Oil Fluid Transfer

Owner's Operation & Safety Manual

All 400B Models

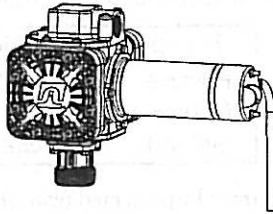

WARNING

This pump should not be used to fuel aircraft. This pump is not suited for use with fluids for human consumption.



WARNING



- Electrical Hazard.
- Improper use or installation can cause serious bodily injury or death.
- Motor must be properly grounded.
- Electrical wiring must be done by a licensed electrician.



WARNING



- Explosion Hazard
- Static charge could result in a fire or explosion.
- Do not use pump with low flash point fluids (100°F or less) or in Hazardous locations.

SAFETY INSTRUCTIONS

1. Use Teflon tape to seal all joints and avoid leakage of fluids being pumped. Leaking of caustic and/or hazardous fluids could result in severe injuries.
2. **Never disassemble YOKE ASSEMBLY (see item 12). This is under extreme pressure and injury could result.**
3. Tank or barrel should be anchored to prevent tipping in both the full and empty conditions.
4. The pump motor is equipped with thermal overload protection. If overheated, it will shut itself off without any damage to the windings. Be sure to turn off the pump power if this occurs. As the motor cools, it will start without warning if power is on.

GENERAL DESCRIPTION

The Tuthill 400B is a double action diaphragm pump, using a patented, spring-driven, self-priming, positive displacement mechanism. The flow rate is up to 13 GPM. The ultimate in chemical handling capability is provided with wetted parts constructed of polypropylene, stainless steel and chemical compatible seals.

OPTIONS

- 825 or 850 electronic digital meters
- 2" NPT inlet bung in plastic or metal
- Wrap around tubular mounting frame
- 12 VDC, 24 VDC, 115 VAC/60 Hz, or 240 VAC/50 Hz motor
- Santoprene® or Filcon® diaphragm

TECHNICAL INFORMATION

Design Features

- 1" suction & discharge fittings
- 15 PSI maximum outlet pressure
- 8" Hg "dry" lift (9 feet of water)
- 2600 RPM, 1/4 HP motor:
 - 12 VDC rated at 20 amps
 - 24 VDC rated at 10 amps
 - 115 VAC/60 Hz rated at 2.5 amps
 - 230 VAC/50 Hz rated at 1.1 amps
- Thermal overload protection of the motor
- 20 ft. long power cable with battery clips (12 Volt DC only) and a 30 amp fuse
- Positive displacement/self-priming design
- Can pass particulate materials up to 0.100" diameter in the pumped fluids
- Pump may run dry without damage
- Handles viscosities from 1.0 CPS to 3700 CPS
- Minimum shear (agitation) of pumped fluids
- Does NOT include inlet strainer
- Minimum operating ambient temperature: -10°F (-23°C)
- Maximum operating ambient temperature: 130°F (54°C)
- Overall dimensions: 14" (35.6 cm) long x 8.25" (21 cm) high x 8.75" (22.2 cm) deep
- Maximum 30 minute duty cycle, NOT for continuous operation

INTENDED USE

The 400B chemical transfer pump is designed for low-pressure transfer of non-flammable fluids.

Fluid Compatibility

The 400B Series pump is compatible with agricultural, industrial chemicals and lubricants. Model numbers reference the diaphragm material.

- Models that begin with "SS" (example SS415B) contain the Santoprene® diaphragm that is designed for use with chemicals.

- Models that begin with "FR" (example FR410B) contain the Filcon® diaphragm which is designed for use with oils and lubricating fluids.

The 400 Series pump is NOT compatible with:

- Strong acids (pH of 3.5 or below)
- Strong bases (pH above 12)
- Flammable fluids (flash point below 100°F)
- Bleach (Sodium Hypochloride)

Wetted Materials

- Polypropylene body and valves
- Stainless steel fasteners
- Hastalloy check valve springs
- Nitrile (Buna-N) seals utilize "captured" (static) design, ideal for sealing aggressive chemicals
- Santoprene® or Filcon® diaphragms

MECHANICAL INSTALLATION

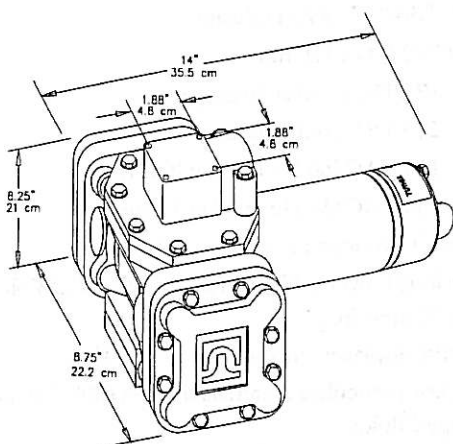

1. Provide a sturdy, safe pump mounting. Drums must be supported to prevent tipping over when empty.
2. Use oil resistant pipe compound on all threaded fluid connections.
3. Tighten plastic fittings until "snug". **Do not over tighten.**
4. Tanks and containers must be vented to prevent collapses.
5. Suction Installation Best Practices
 - Use a 10 mesh screen (or higher mesh) on the suction inlet if there are solids or debris in the fluid to be pumped.
 - Foot valves are **not** recommended unless they have pressure relief built into them.
 - Suction lift should not exceed 9 feet for water (less if fluid is heavier than water).
 - Suction pipe should be 1" diameter or larger. It should terminate 2" from the bottom of the tank **unless** the fluid is known to have no contaminants. Suction hose should be reinforced to prevent collapse.
6. Discharge Installation Best Practices
 - Use at least 1" discharge hose or pipe
 - Use compatible hose:
 - EPDM for chemicals
 - Nitrile (Buna-N) for oils and lubricants

7. Long hoses will restrict flow. See chart below to estimate flow rate based on fluid viscosity (thickness) and length of hose.
8. For best performance, use high flow components. Automatic shut-off nozzles will restrict flow.

ELECTRICAL INSTALLATION

DC Only

- 12 VDC, 20 Amps, 1/4 Hp (185 watts) motor
- 24 VDC, 10 Amps, 1/4 Hp (185 watts) motor

- A. A 30 amp fuse must be installed in the positive (red) wire.
- B. Connect cable to 12 Volt DC power supply as follows, paying special attention to wire colors:

Pump	Cable
Positive	Red
Negative	Black
Ground	Green

- C. Power cable must be protected from sharp edges.

AC Only

- 115VAC, 60Hz, 2.5 Amps, 1/4 Hp (185 watts) motor
- 230 VAC, 50Hz, 1.1 Amps, 1/4 Hp (185 watts) motor

- A. All wiring must be done by a licensed electrician in accordance with approved electrical codes.
- B. Power must be supplied by a licensed electrician in accordance with approved electrical codes.
- C. Circuit must be grounded.
- D. Power cable must be protected from sharp edges.

CALIBRATION

If a meter is used, calibrate according to the instructions in the meter's Owner's Operation & Safety Manual.

ASSEMBLY/DISASSEMBLY

NOTE: Pump should be thoroughly flushed prior to disassembly.

Motor/Gear Assembly Removal (Refer to exploded view of pump)

1. If possible, position pump with sight caps down.
2. Remove four screws (item 20) and lift out motor/gear assembly (items 1 and 24).
3. Drain oil from pump if additional maintenance to pump is required.

Gear Assembly Replacement

1. Remove six screws (item 25) and pull gear assembly from motor.
2. Pull drive gear (item 27) and key (item 28) from motor shaft.

DO NOT DISASSEMBLE GEAR ASSEMBLY. Planet gears and ring gear are marked for proper assembly and must not be altered. **DO NOT ATTEMPT TO REPLACE INDIVIDUAL PARTS. REPLACE ENTIRE ASSEMBLY WHEN REQUIRED.**

Diaphragm Assembly/Check Valve Replacement

NOTE: Diaphragm and check valve assemblies can be serviced without removing oil from pump body by removing one at a time with diaphragm facing up. Care must be taken not to contaminate oil.

1. Remove 8 diaphragm cover screws and diaphragm cover.
2. Remove retainer screws (item 11) and o-rings (item 4).
3. Remove diaphragm assembly by pulling check valves out of pump body. be careful not to damage surface of body.
4. Install new diaphragm assembly in the same orientation as the one that was removed.
5. Insert four screws (item 11) and o-rings (item 42) into diaphragm as shown and tighten to 35 in. lbs. of torque.
6. Install diaphragm cover (item 4). Hand start and tighten torx head screws to 75 in. lbs.

To further disassemble pump, after step #3 above:

7. Remove motor and drain oil, if complete disassembly is required.
8. Remove four screws (item 19) holding bearing plate (item 17).
9. Remove bearing plate (item 17) and thrust plate (item 16).
10. Remove drive shaft (item 13), bearing (item 14), bearing ring (15) and yoke assembly (item 12).

Never disassemble YOKE ASSEMBLY. This is under extreme pressure and injury could result.

Assembly in reverse order. Hand start and tighten torx head screws to 75 in. lbs.

MAINTENANCE

To keep pump running at its best, periodically perform the following procedures. (Refer to exploded view drawing of pump)

Chemical Applications

Do not allow chemical to remain in the pump for any extended period of time, whereby the chemicals are allowed to "dry out." Thoroughly rinse pump and meter by flushing the pump with water or appropriate flushing fluid.

DO NOT USE PRESSURIZED WATER OR PRESSURIZED AIR to flush your Sotera Systems pumps. Damage to the equipment can occur if flush water pressure exceeds 15psi (1 bar). Instead, submerge the suction tube or inlet adapter in clean water and dispense water by operating the pump. Dispose of the flush water properly. After flushing, pump air to remove as much water as possible.

All Applications on annual basis or as needed.

1. Tighten all external torx head screws to 75 in. lbs. (items 19 & 23).
2. Drain oil through sight caps and replace oil with approximately 16 ounces of automotive grade SAE 30W through one of the sight cap holes. The oil level should be level with the bottom edge of the sight caps (item 30) located on the front of the pump body.

NOTE: Always check oil level when the pump is level.

NOTE: If external torx head screws (items 19 & 23) are removed, hand start and tighten to 75 in. lbs. Tighten motor flange hex head screws to 50 in. lbs.

**SERIES 400B DIAPHRAGM PUMP
TYPICAL FLOW RATE FOR VARIOUS VISCOSITIES**

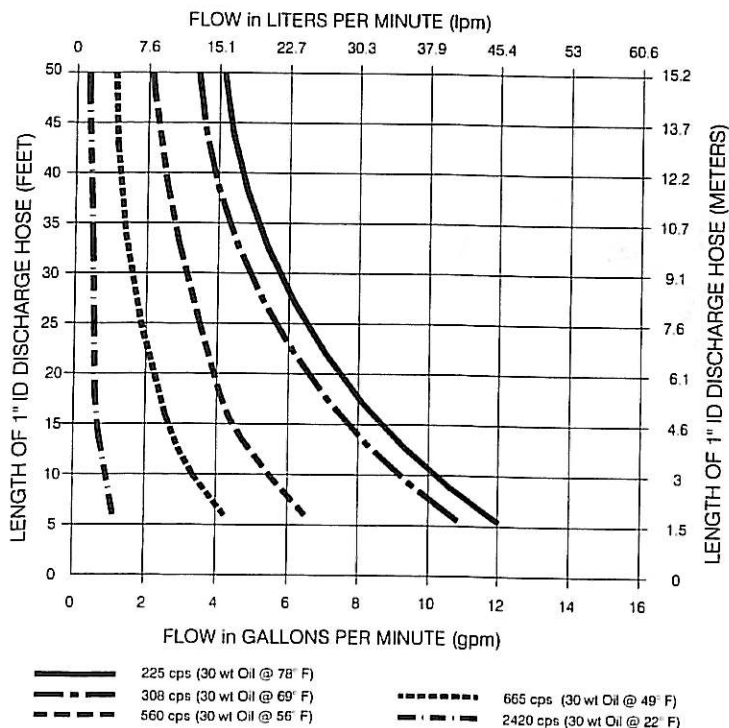

NOTES:

1. **SUCTION LOSSES.**
Test pump was mounted on a 55 gallon drum of oil, 1/2 full. A SOTERA 1" suction pipe was used.
A longer or smaller diameter inlet pipe will lower the flow rate.
2. **VERTICAL HEAD LOSSES.**
Test hose was horizontal with pump. Add 3 feet of hose for each 1 foot of vertical rise.
3. **OTHER LOSSES.**
Elbows, quick-disconnects, swivels, and check valves in outlet or inlet hoses will restrict the flow.
Add the estimated length of hose for each component used.
1" SureStop + 0.5 feet
Other 1" disconnects + 13.0 feet
1" Check Valves + 8.7 feet
1" Elbow + 2.6 feet

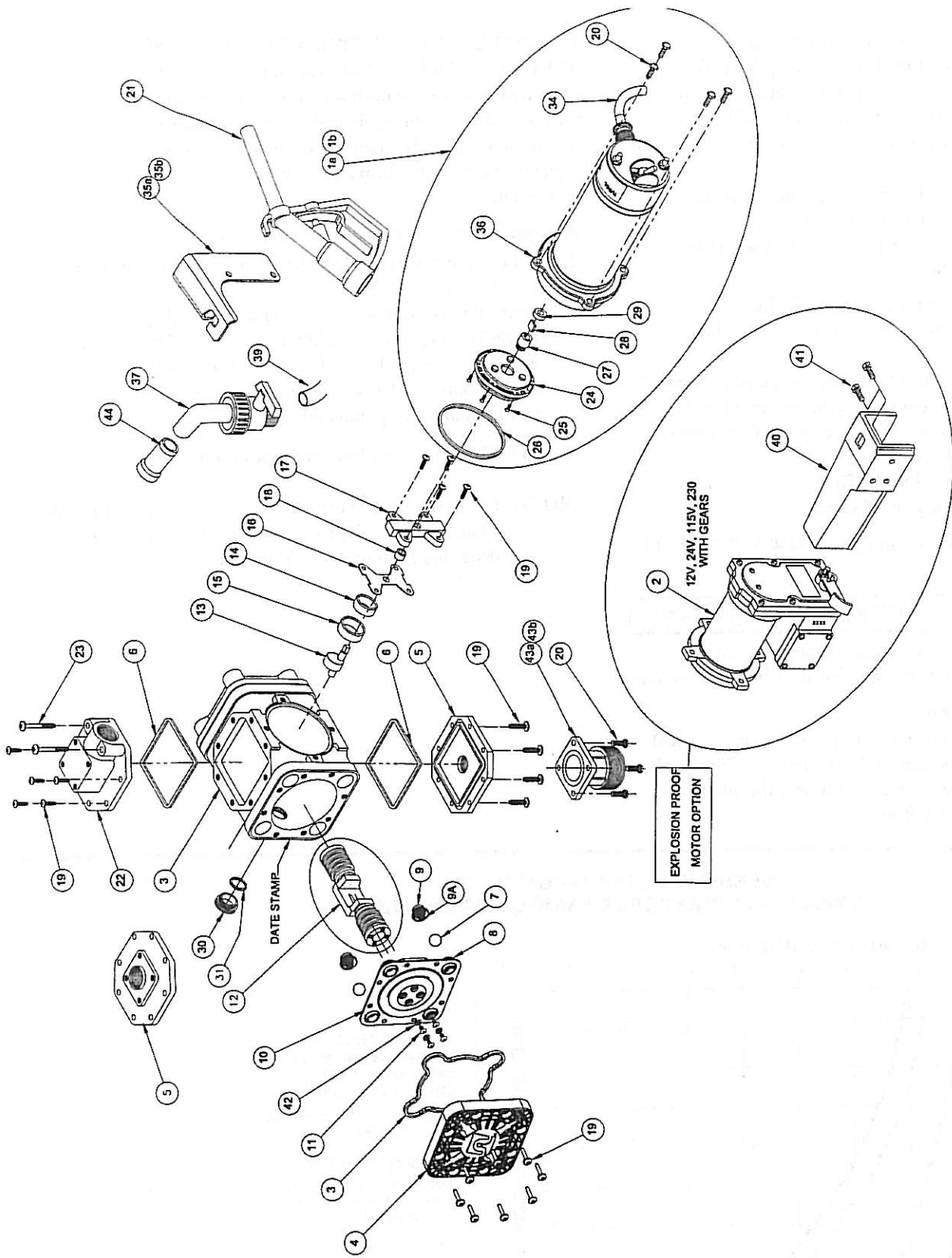

SERIES 400 PUMP PARTS LIST

ITM. NO.	PART NO.	DESCRIPTION	QTY.
1a	400G9734	12 VDC Motor with gears	Opt.
1b	400G9735	115 VAC 60 Hz Motor with gears	Opt.
2a	400EXPF6846	Motor Assembly - 12 VDC EXP PROOF	Opt.
2b	200EXPG7738	Motor Assembly - 24 VDC EXP PROOF	Opt.
2c	400EXPF7351	Motor Assembly - 115 VAC EXP PROOF	Opt.
2d	400EXPG7186	Motor Assembly - 230 VAC EXP PROOF	Opt.
3	400H1164	Diaphragm Cover Gasket	2
4	400H1154	Diaphragm Cover	2
5	400F6569	Flange, straight	1
6	400F6924	Gasket Inlet Flange	2
7	400F6574	Check Valve Ball	8
8	400H1171	O-ring (-117) (Included w/Item 7)	8
9a	400H1180	Outlet Check Valve Assembly w/spring	4
9b	400G7163	Check Valve Spring (Included in 9 & 10)	8
10a	400H1178	Diaphragm Assm - Santoprene™ Green	2
10b	400H1179	Diaphragm Assembly Black Ficon	Opt.
11	400F6795	#10-24 x 1/2 THMS	8
12	400F6781	Yoke Assembly	1
13	400F6800	Drive Shaft	1
14	400F6819	Eccentric Bushing	1
15	400F6827	Bearing Ring	1
16	400F6880	Thrust Plate	1
17	400F6579	Bearing Plate	1
18	400F6693	Shaft Bushing	2
19	400G9685	1/4 x 1" PTS screw, SS	34
20	400F6792	1/4-20 x 3/4 HHCS	8
21	6U100	Nozzle, Aluminum	1
22	400F6679	90° Flange with inserts	1
23	400G9687	1/4 x 2.3" PTS screw, SS	2
24	400F6557	Gear Assembly (Included w/Item 1 or 2)	1
25	400G7494	#6-32 x 1/2 FHMS (Incl. w/Item 1 or 2)	6
26	400F6692	Gasket Motor Flange	1
27	400F6563	Drive Gear (Included w/Item 1 or 2)	1
28	1200F6440	Drive Key (Included w/Item 1 or 2)	1
29	400G9104	Shaft Seal (Included w/Item 1 or 2)	1
30	400F6818	Sight Cap, Polypropylene	2
31	400F6813	O-ring (-022)	2
34	1200F7207	Cable 20 feet (DC Only)	20 FT
35a	400G9736	Nozzle Holder, Aluminum Nozzle	Opt.
35b	400G9737	Nozzle Holder, Poly Nozzle	Opt.
36	400F6566	Gear Housing (Included w/Item 1 or 2)	1
37	400G7006	Ball Valve Nozzle, 1", Poly Nozzle	Opt.
39a	700F3123	1" x 12' EPDM Hose	Opt.
39b	410F3137	1" x 12' Nitrate Hose w/Threaded Ends	Opt.
40	700F6748	Nozzle Cover (Explosive Proof motor)	Opt.
41	600F2220	5/16-18 x 3/4 HHCS	Opt.
42	400G8887	O-Ring (007)	8
43a	400G9140	Bung Adapter - NPT	Opt.
43b	400F6528	Bung Adapter - Buttress	Opt.
44a	400KTF0237	Anti-Drip Spout - Fluorocarbon	Opt.
44b	435G9126	Anti-Drip Spout - EPDM	Opt.
	400F7320	Power Cord (115 VAC Only) (Not Shown)	Opt.
	650G7185	Power Cord (230 VAC Only) (Not Shown)	Opt.
	400F1855	Suction Pipe, Polypropylene (Not Shown)	Opt.

WHEN ORDERING REPAIR PARTS, BE SURE TO GIVE REPLACEMENT PART NUMBER, DATE OF MANUFACTURE AND PUMP SERIES NUMBER. THIS WILL ENSURE THAT THE CORRECT REPLACEMENT PART IS SUPPLIED.

400KTH1126

Series, 400B Repair Kit
(Includes Items 6, 7, 8, 9, 10, 11, 24-28, 42)

TROUBLESHOOTING GUIDE

PROBLEM	POSSIBLE CAUSE	SOLUTION
Pump won't prime	<ul style="list-style-type: none"> • Suction line problem • Leaky check valves • Check valves improperly installed • Outlet plugged • Motor not operating • Stripped or damaged gears 	<ul style="list-style-type: none"> • Check for leaks in suction line. • Check for dirt or damaged check valves and replace. • Check for proper installation. See below. • Check for blockage and clear. • Check power source. • Repair or replace motor. • Check gear assembly and drive gear for damage. Replace complete assembly if necessary.
Pump hums but will not rotate	<ul style="list-style-type: none"> • Motor faulty • Gear mechanism jammed 	<ul style="list-style-type: none"> • Replace motor. • Check for free rotation of the gears.
Low pump capacity	<ul style="list-style-type: none"> • Low voltage • Leaky suction line • Dirt in check valves • Faulty check valves • Debris ingested 	<ul style="list-style-type: none"> • Check power source. • Repair leaks. • Dismantle and clean. • Install repair kit. • Add inlet screen.
Motor overheats	<ul style="list-style-type: none"> • Pumping hot fluids • Motor faulty 	<ul style="list-style-type: none"> • Shorten duty cycle. • Replace motor.
Fluid leakage	<ul style="list-style-type: none"> • Faulty or missing gaskets • Loose bolts • Cracked component 	<ul style="list-style-type: none"> • Install all gaskets specified in parts list. • Torque all 1/4" torx head bolts to 75 in. lbs. • Torque hex head 1/4-20 motor bolts to 50 in. lbs. • Replace defective component.

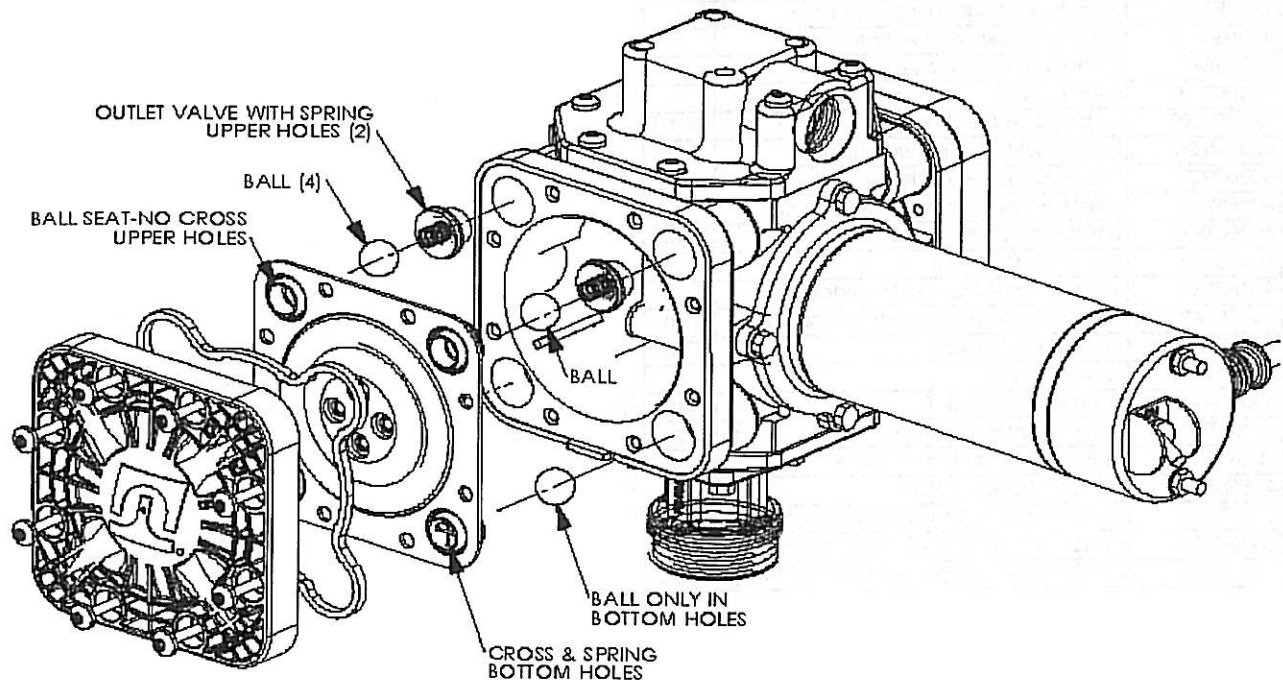

Model 445 (DC), 485 (AC)

MIX & GO®

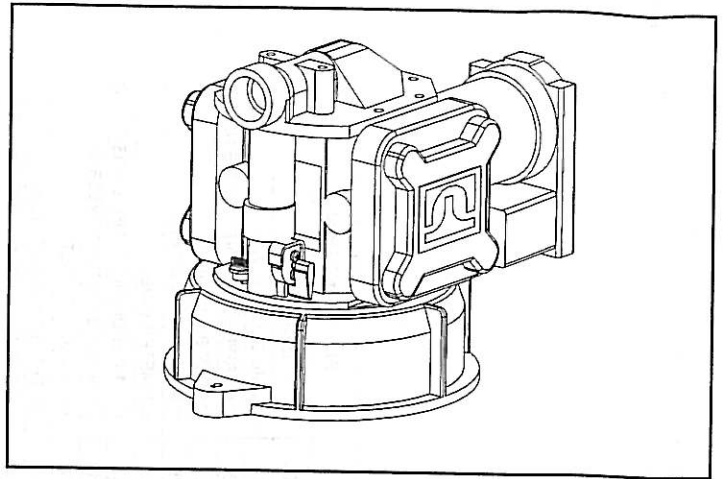
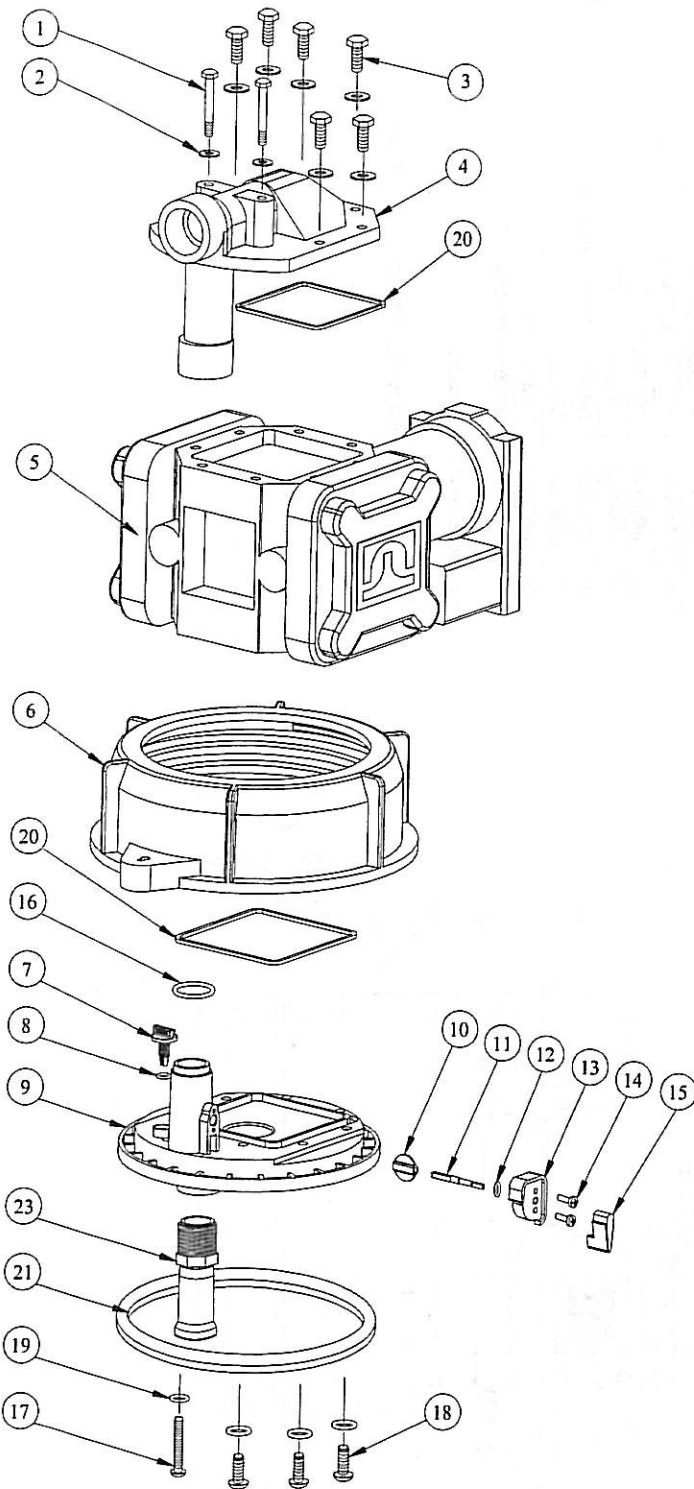

445F1622 DC PUMP SUBASSEMBLY 445G8061 AC PUMP SUBASSEMBLY

ITM. NO.	PART NO.	DESCRIPTION	QTY.
1	400F6817	1/4-20 x 2 1/2" Bolt	2
2	400F6793	1/4 Washer	8
3	400F6792	1/4-20 x 3/4" Bolt	6
4	400F0183	Outlet Flange	1
5		Basic Ag Pump 445 AC	1
		Basic Ag Pump 485 AC	opt
6	400F1525	Snyder Gem Cap	1
7	445F1634	Vent Assembly with O-Ring	1
8	445F1635	Vent O-Ring (Included w/item 7)	1
9	445F1587	Inlet Flange	1
10	440F1592	Valve	1
11	445F1609	Shaft	1
12a	800F4036	O-Ring	1
12b	800F4034	O-Ring EPDM	opt
13	440F1589	Bushing	1
14	445G9008	Screw	2
15	440F1588	Handle	1
16a	442F0214	O-Ring	1
16b	445G9113	O-Ring EPDM	opt
17	445F1610	Long Phillips Screw	2
18	400F0267	Short Phillips Screw	6
19	900F8159	O-Ring	8
20	400F6924	Gasket	2

SS465 Chemtraveller®

BILL OF MATERIAL			
ITEM NO.	PART NO.	DESCRIPTION	NO. REQD
1	400F6892	FRAME-GLOSS BLACK	1
*2	400G7006	1" NORWESCO VALVE/NOZZLE NO TIP	1
3	400F3622	1" POLY BALL VALVE	2
4	400F3428	1" POLY SHORT NIPPLE	1
*5	400F1703	825 METER (SUB)	1
6	435F3457	1" X 14" EPDM DISCHARGE HOSE (RED)	1
7	400F6679	90° FLANGE W/BRASS INSERTS	2
8	400F6817	1/4" X 2.25" SS BOLT	4
9	400G9156	400 SERIES 110V AC PUMP	1
10	435F3455	1" X 9" EPDM SUCTION HOSE (BLACK)	1
11	39G7046	1" POLY STREET ELBOW / BARB	1
13	400F3618	1" FEMALE COUPLER	1
15	400F6792	1/4" X 3/4" SS BOLT	4
16	400F3436	1/2" PUSH NUT	2
17	400F3437	WHEEL, 6" X 1.5"	2
18	400F3623	SHAFT, 1/2" DIA. X 19.8" LG.	1
19	400F3438	SPACER	2
20	400F1671	HOSE CLAMP	4
21	400F1672	HOSE BARB ADAPTER, 1"	3

*NOT INCLUDED IN ALL MODELS

400KTF6867 WHEEL KIT INCLUDES ITEM 16-19

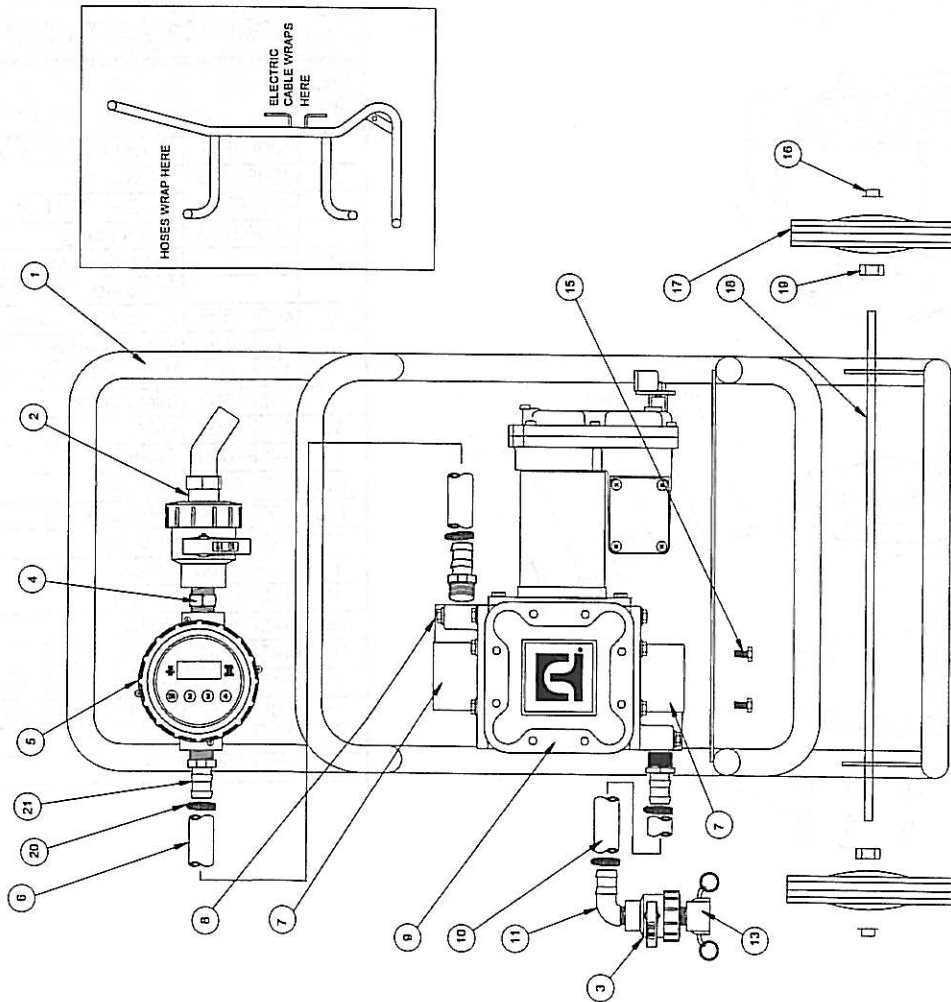

SS435 Chemtraveller®

BILL OF MATERIAL			
ITEM NO.	PART NO.	DESCRIPTION	NO. REQD
1	400F6832	FRAME-GLOSS BLACK	1
*2	400G7006	1" NORWESCO NOZZLE NO TIP	1
3	400F3622	1" POLY BALL VALVE	1
4	400F3428	1" POLY SHORT NIPPLE	1
*5	800F1703	825 METER	1
6a	435F3457	1" X 14' EPDM DISCHARGE HOSE, RED	1
6b	400F3140	1" X 12' NYALL HOSE, BLACK	OPT
7	400F6679	90° FLANGE, BRASS INSERTS	2
8	400F6817	1/4" X 2.25" SS BOLT	4
9a	400F6909	PUMP SUB, 12VDC, SANTOPRENE	1
9b	400G7098	PUMP SUB, 12VDC, SANTOPRENE, SS INSERTS	OPT
9c	400G7163	PUMP SUB, 12VDC, SANTOPRENE, SS INSERTS, HASTELLOY SPRINGS	OPT
10a	435F3455	1" X 9' EPDM SUCTION HOSE, BLACK	1
10b	400F3140	1" X 12' NYALL HOSE, BLACK	OPT
11	39G7046	1" POLY STREET ELBOW / BARB	1
13	400F3618	1" FEMALE COUPLER	1
14	400F2702	12V CABLE ASSEMBLY W/CLIPS	1
15	400F6792	1/4" X 3/4" SS BOLT	4
17	400F1671	HOSE CLAMP	4
18	400F1672	HOSE BARB ADAPTER, 1"	3

*NOT INCLUDED IN ALL MODELS

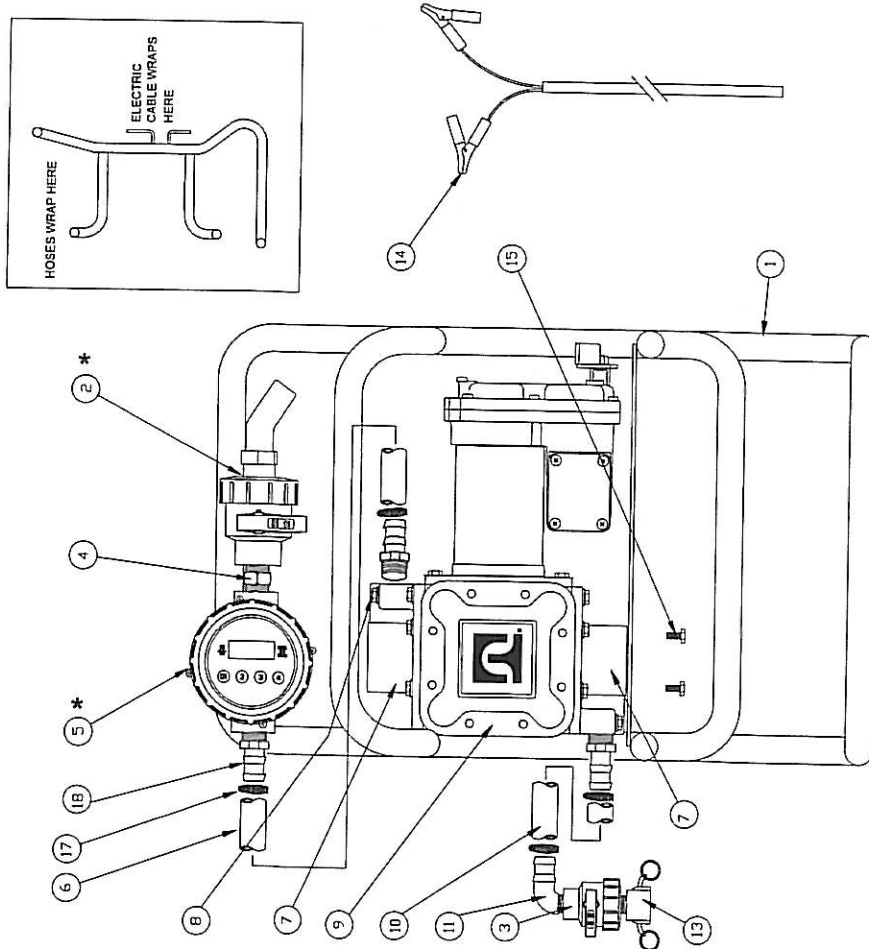



PRODUCT WARRANTY

Sotera Systems of Tuthill Corporation ("Manufacturer") warrants to each buyer of its products ("the Buyer") for a period of 12 months from date of invoice or sales receipt but in no event more than 18 months from date of manufacture that goods of its manufacture ("Goods") will be free from defects of material and workmanship. Manufacturer's sole obligation under the foregoing warranties will be limited to either, at Manufacturers' option, replacing or repairing defective Goods (subject to limitations hereinafter provided) or refunding the purchase price for such Goods theretofore paid by the Buyer, and Buyer's exclusive remedy for breach of any such warranties will be enforcement of such obligations of Manufacturer. If Manufacturer so requests the return of the Goods, the Goods will be redelivered to Manufacturer in accordance with Manufacturer's instructions F.O.B. Factory. The remedies contained herein shall constitute the sole recourse of the Buyer against Manufacturer for breach of warranty. IN NO EVENT SHALL MANUFACTURING BE LIABLE FOR CONSEQUENTIAL DAMAGES NOR SHALL MANUFACTURER'S

LIABILITY ON ANY CLAIM FOR DAMAGES ARISING OUT OF THE MANUFACTURE, SALE, DELIVERY OR USE OF THE GOODS EXCEED THE PURCHASE PRICE OF THE GOODS. The foregoing warranties will not extend to Goods subjected to misuse, neglect, accident or improper installation or maintenance, or which have been altered or repaired by anyone other than Manufacturer or its authorized representative. THE FOREGOING WARRANTIES ARE EXCLUSIVE AND IN LIEU OF ALL OTHER WARRANTIES OF MERCHANTABILITY, FITNESS FOR PURPOSE OF ANY OTHER TYPE, WHETHER EXPRESS OR IMPLIED. No person may vary the foregoing warranties and remedies except in writing signed by a duly authorized officer of Manufacturer. Warranties or remedies that differ from the foregoing shall not otherwise be binding on Manufacturer. The Buyer's acceptance of delivery of the Goods constitutes acceptance of the foregoing warranties and remedies, and all conditions and limitations thereof.