

Instruction

Overload protection iSave 21

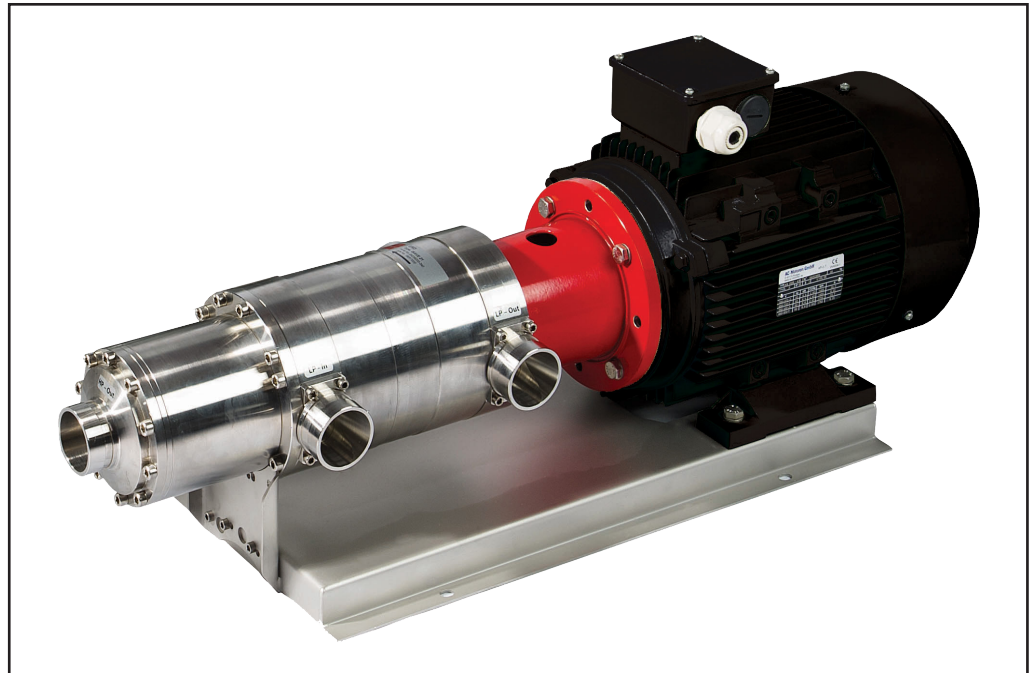

iSave 21



Protection by VFD.

The Danfoss VLT 302 series can provide the speed control and overall protection of both the electric motor and the mechanical parts in the iSave. For full protection on both the iSave and the electrical motor, one VLT must be used for each iSave. See Electrical schematic diagram on page 3. Alternative one VLT can control the speed of several iSaves. But the overload protection of the electrical motors and torque limitations on the iSaves must be provided by additional equipment. This can be done by a mechanical coupling between the electrical motor and the iSave (See page 7) or by a "current monitoring relays", see page 4.

Danfoss VLT 302 parameter setup

For detailed information of the VLT see the operation instruction supplied together with the VLT. At initial start up of the VLT run the "initialising" Parterre settings:

Par. No. #	Parameter description	Set value
341	Ramp up	10 second
416	Current limit control, proportional gain	1)
1425	Current limit control, time	0 second

1) Current limit must be calculated according to maximum torque of the iSave. See datasheet 521b1116.

Danfoss VLT302 with one iSave

Electrical schematic diagrams according to EN60204-1

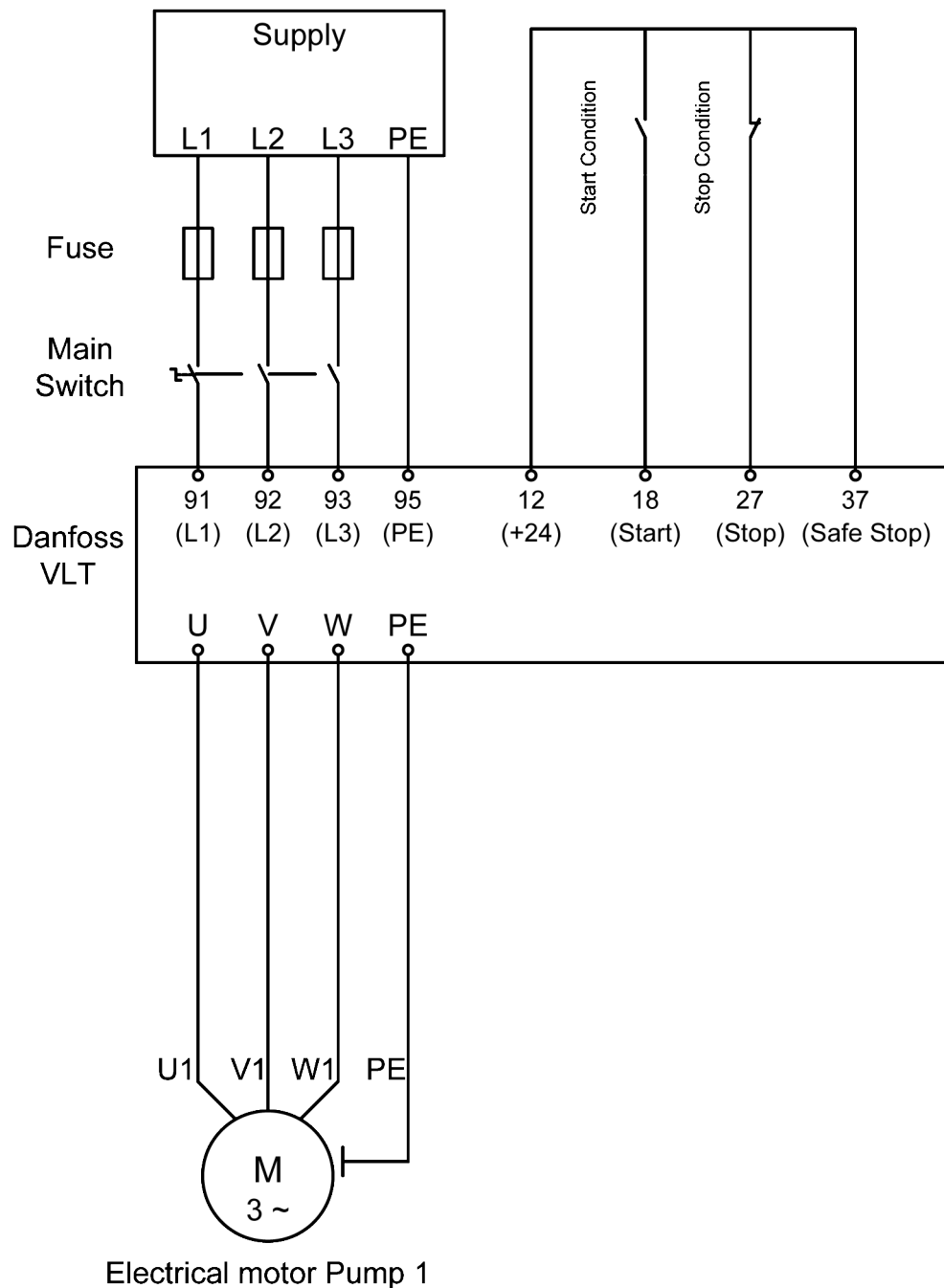

Protection by a current monitoring relays

The current monitoring relays constantly measure the current in an electrical wire. The current is indirectly reflecting the torque on the electrical motor. If the measured value exceeds the adjusted threshold value the relay sent a signal to a main switch that cut of the power to the electrical motor.

When using a current monitoring relays together with a VFD attention must be on choosing a VFD compatible relay.



A standard thermo relay is not an acceptable protection for the overload protection of the iSave. This is because of the slow reaction time of the relay.

Danfoss VLT302 with two iSaves

Electrical schematic diagrams according to EN60204-1

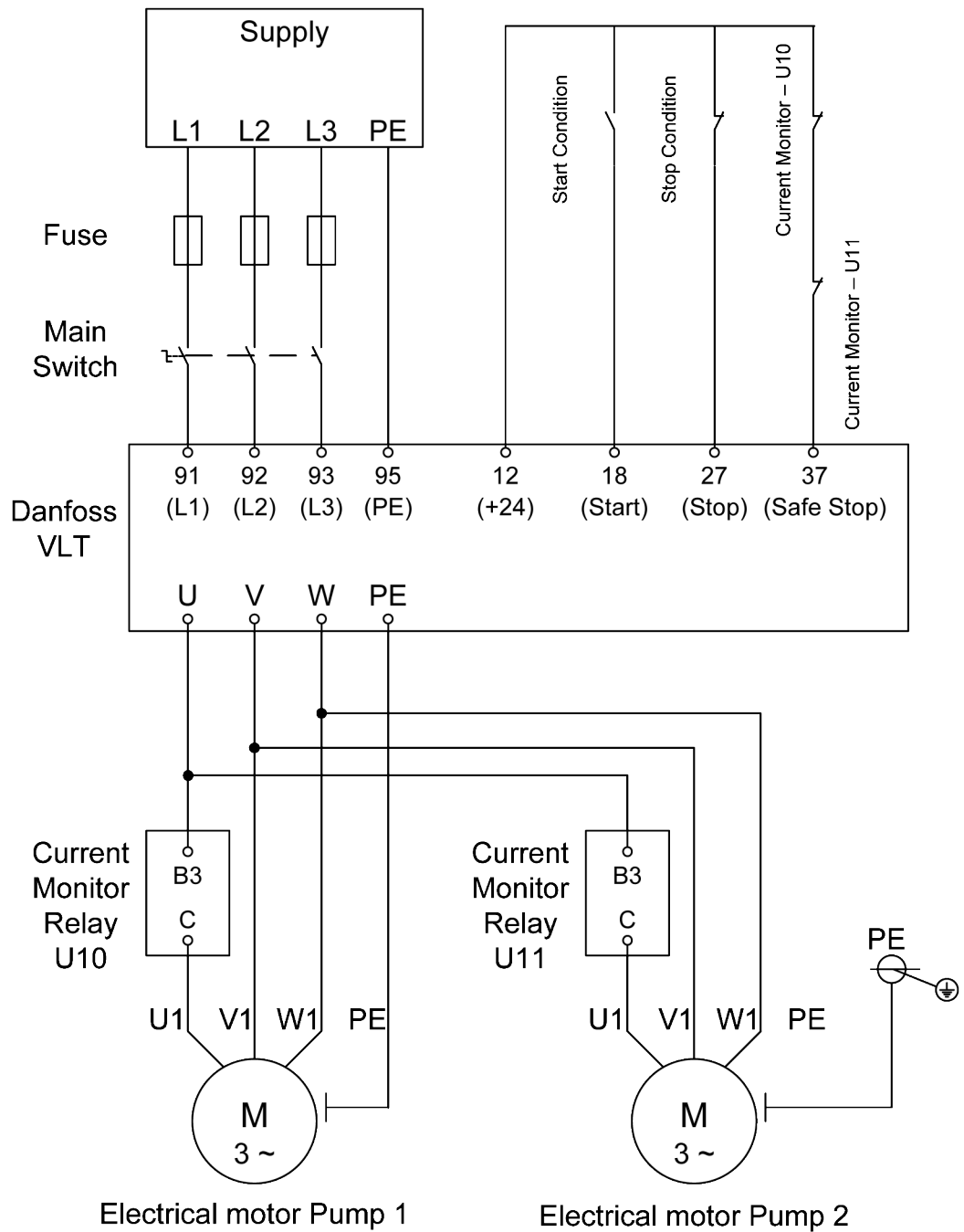

Soft starter with one iSave

Electrical schematic diagrams according to EN60204-1

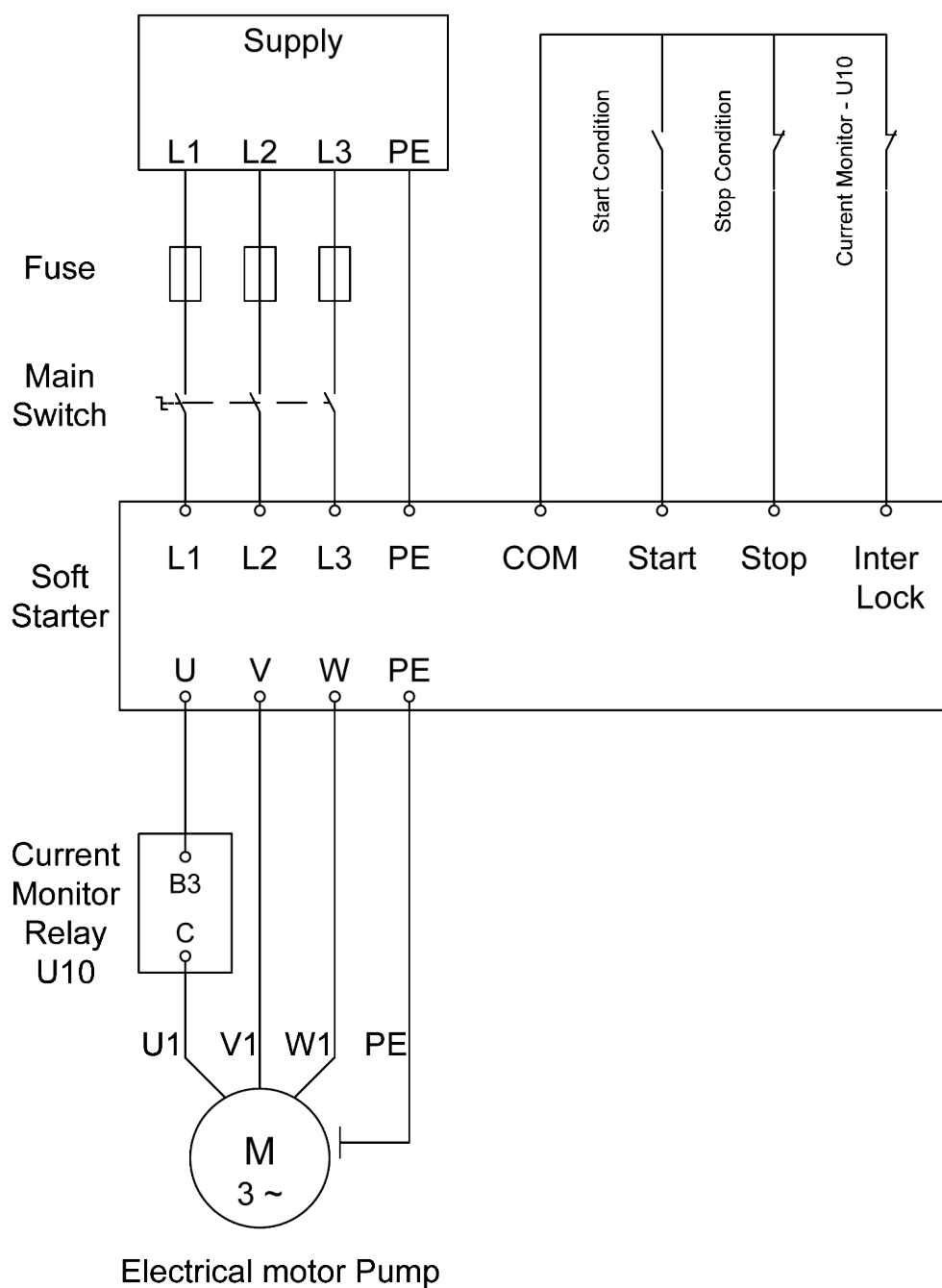

Soft starter with two iSaves

Electrical schematic diagrams according to EN60204-1

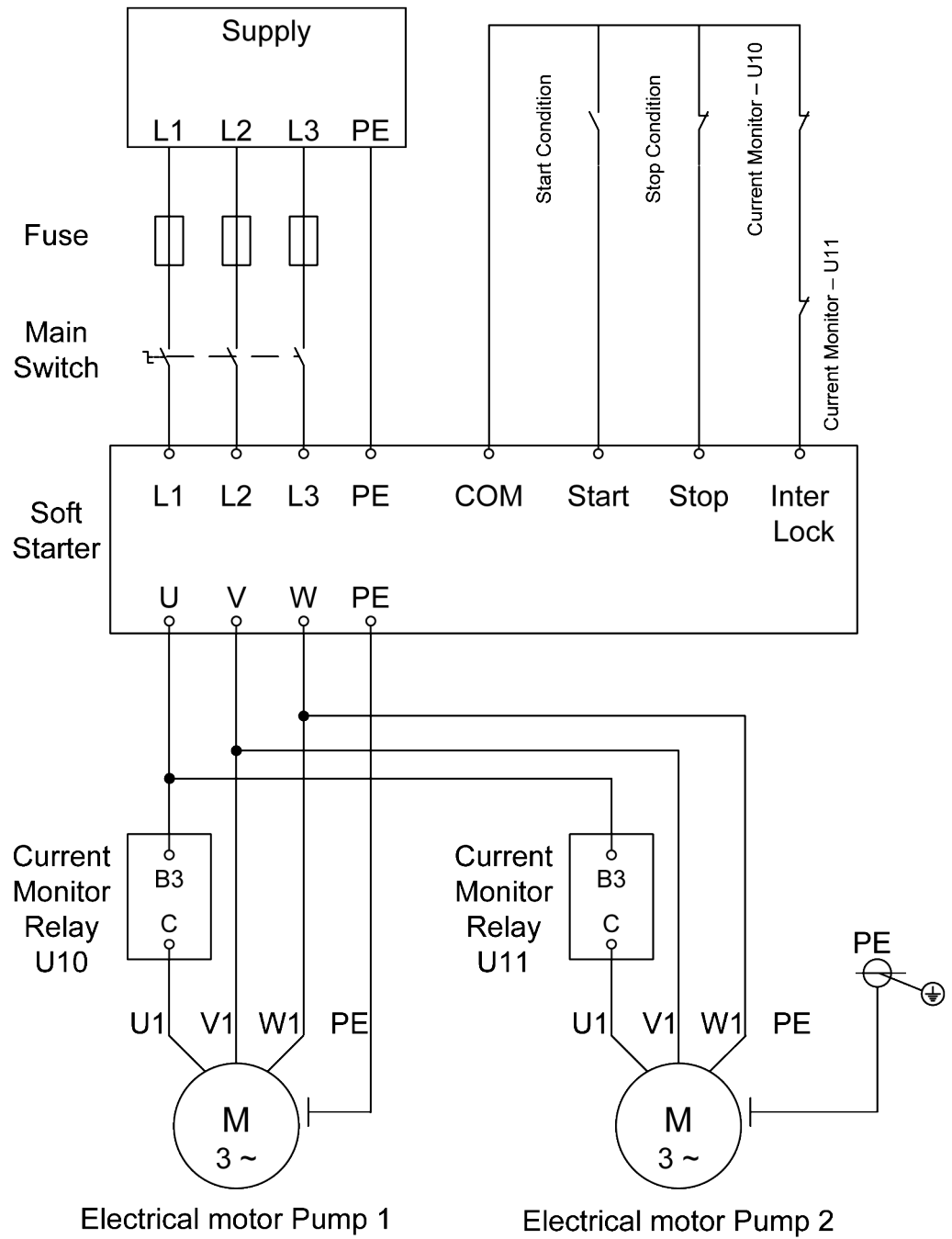

Mechanical coupling

The iSave can be protected against overload by using a Torque Overload Safety Coupling between the electric motor and the iSave.
The Coupling can be purchase by the company www.rw-america.com
Coupling type ES2, 36 Nm

